

Tecofi'Φ

VALVE DESIGNER - FRANCE



VOS PROJETS, NOS SOLUTIONS
Your projects, our expertise



TARIF 2022



FABRICANT FRANCAIS DE ROBINETTERIE
FRENCH VALVES MANUFACTURER



Dernière mise à jour : 31/03/2022
Last update: **March 2022**

UNE EXPERTISE TECHNIQUE *depuis plus de 35 ans !*

Concepteur et fabricant de vannes depuis 1985, nous sommes aujourd'hui un acteur incontournable sur le marché de la robinetterie en France et à l'International.



Groupe TECOFI - TECOFI Group



Over 35 years of TECHNICAL EXPERTISE !

Designer and manufacturer of valves since 1985, we are today a key player in the valve market in France and around the World.



+250

Collaborateurs
Employees



70 %

De l'activité à l'international
International activity



35

Années d'expérience
Years of experience

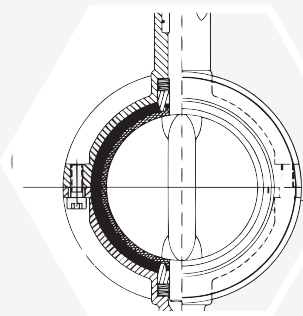

ADAPTABILITÉ ADAPTABILITY

Nous vous proposons des solutions sur mesure, adaptées à vos cahiers des charges.
We offer tailor-made solutions adapted to your specifications.



CONSEIL GUIDANCE

Nous vous accompagnons techniquement tout au long de votre projet.
We provide you support and technical solutions throughout your project.



EXPÉRIENCE EXPERIENCE

Nous mettons notre expérience et notre expertise au service de vos ambitions.
We use our experience to help you to achieve your ambitions.



SATISFACTION SATISFACTION

Nous faisons de votre satisfaction notre priorité.
Your satisfaction is our priority.

NOS DOMAINES D'EXPERTISE

OUR AREAS OF EXPERTISE



NOS FORCES | OUR STRENGTHS



Une entreprise internationale et dynamique
An international and dynamic company



Une expertise technique depuis plus de 35 ans
More than 35 years of technical expertise



Des équipes motivées et compétentes
A motivated and skilled team



Des spécialistes au service de nos clients
Customer service specialists



NOTRE VISION | OUR VISION



"Le monde change et nos ressources naturelles s'épuisent."
Fabien FAYARD - Directeur Commercial / Sales Director

Depuis plus de 35 ans, Tecofi s'adapte et vous accompagne en vous proposant des solutions techniques afin d'améliorer la performance de vos réseaux industriels et diminuer les fuites dans vos réseaux d'eau.

Notre force : la mobilisation de plus de 130 salariés en France (et plus de 250 dans le monde) qui fabriquent pour vous, à côté de Lyon, des équipements de robinetterie.

Notre promesse : vous offrir des solutions de qualité, rapides et adaptées à vos besoins. La garantie d'un fabricant indépendant à capitaux 100% français avec une expertise et une renommée dans plus de 80 pays.

Grâce à une forte présence à l'international, nous mettons en avant le savoir-faire français et les valeurs humaines que nous partageons fondées sur le respect des valeurs environnementales et d'un management respectueux et participatif.

Pour réussir ensemble tous vos projets, nous avons regroupé dans ce nouveau catalogue l'étendue de notre gamme. De nouveaux produits innovants ainsi que de nouvelles options qui vous permettront de réduire vos coûts de maintenance et de réaliser des économies d'énergie.

Soulignons ainsi la nouvelle gamme de clapet à fermeture rapide qui est venue rejoindre notre stock afin de diminuer les coups de béliers sur vos installations.

Nous développons sans cesse de nouveaux produits et certifions l'ensemble de notre gamme selon les normes internationales. Nos équipes commerciales et techniques sont à votre disposition et vous apportent le sérieux et la réactivité d'un fabricant de renom.

Nous ne cesserons jamais de remercier nos partenaires qui chaque jour participent à l'aventure TECOFI.

Continuons à *" toujours rechercher la difficulté, non pas le danger. Aller de l'avant, tenter, oser, dans l'audace il y a l'enchantement "* (Gaston Rebuffat)

L'ADN du groupe TECOFI réside dans le challenge, le dynamisme, la résilience et surtout dans ses hommes et ses femmes qui font son histoire et la compose. TECOFI est une marque française audacieuse et ambitieuse.

"The world is changing and our natural resources are depleting"

For over 35 years, Tecofi has been swift, adapting to offer technical solutions to help you improve the performance of your industrial networks and reduce leaks in your water networks.

Our strength is in the involvement of more than 130 Tecofi employees in France (and more than 250 around the world), who produce near Lyon your valve equipment.

Our promise is to offer you quality solutions that are fast and adapted to your needs. The guarantee of an experienced and independent manufacturer renowned in more than 80 countries.

Thanks to a strong international presence, we put forth French know-how and shared human values that are founded in respect for the environment and conscientious, participative management.

To manage all of your projects, we have brought together the expanse of our product ranges in a new catalogue. Some new innovated products. Some with new options to discover. They will help you reduce maintenance costs and save energy.

Also highlighting the new range of quick-closing check valves that joins our stock, reducing the water hammer effect in your installations.

We are continually developing new products, certifying them according to international standards. Our sales and technical teams are there for you and offer you the seriousness and reactivity of a renowned manufacturer.

We cannot thank our partners enough who take part in the TECOFI adventure every day.

Continuing to *"always look for the challenge, not just the danger. Go forth, try, dare boldly. It is enchanting."* (Gaston Rebuffat)

Challenge, energy, resilience, and most importantly the people who make up the company are all part of TECOFI's DNA. TECOFI is a daring and ambitious French brand.

NOS VALEURS | OUR VALUES



DIVERSITÉ
DIVERSITY



DYNAMISME
DYNAMISM



HUMAIN
PEOPLE-CENTRIC

NOS ENGAGEMENTS | OUR INVOLVEMENT

"En tant qu'acteur majeur dans la fourniture de robinetterie pour l'eau, nous devons, à l'image de nos clients, être exemplaires en matière d'environnement."

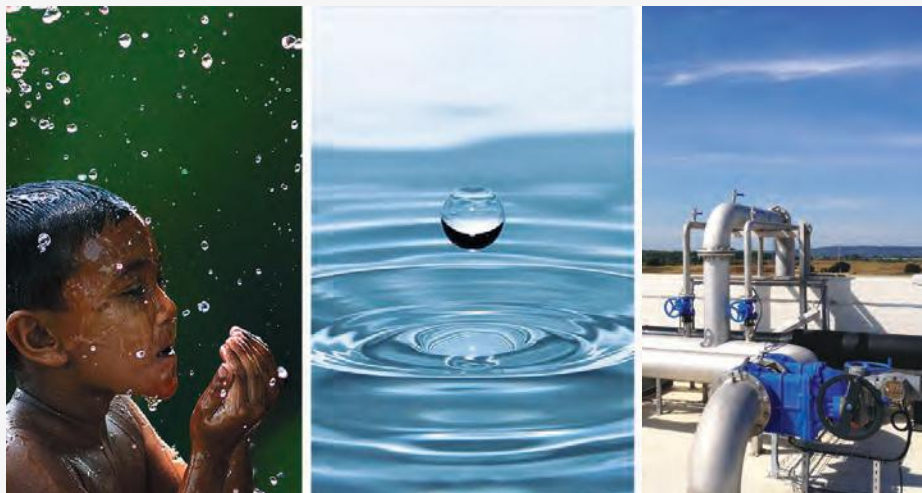

L'EAU ET SES ENJEUX

À l'échelle mondiale, le traitement des eaux constitue le premier enjeu de santé publique.

Nos produits sont spécialement conçus pour répondre aux besoins des stations d'épuration et de traitement des eaux afin de garantir des résultats optimaux lors du processus d'exploitation. Nous sommes en mesure d'apporter notre expertise pour des projets de pompage, irrigation et adduction d'eau.

"As a major player in water valve manufacturing, we must set an environmental example for our clients."

WATER AND ITS ISSUES

On a global scale, water treatment is the number one public health issue.

Our products are especially known to meet the needs of water treatment plants and guarantee optimal results during the operation process. We provide tailor-made products for pumping, irrigation and transition mains. We supply valves for projects that provide more people with access to water.

ENVIRONNEMENT | ENVIRONMENT



TECOFI s'engage pour l'environnement afin de préserver les ressources naturelles et améliorer la gestion de la ressource en eau (traitement, distribution...)

TECOFI is committed to the environment, to preserve natural resources, and to improve water resource management (treatment, distribution, etc.).

Dans le cadre de la certification ISO 14001, notre vision stratégique s'oriente vers la qualité et le respect de l'environnement afin d'assurer le développement et la pérennité de notre entreprise de manière éthique et responsable.

As part of the ISO 14001 certification, our strategic vision is fully steered towards quality and respecting the environment to ensure the development and the sustainability of our company in an ethical and responsible way.

Un système de management environnemental a été mis en place dans le but de gérer l'impact de nos activités sur l'environnement.

Our expertise is deliberately focused on preserving the environment.

CERTIFICATIONS

Nous garantissons des produits d'un haut niveau de qualité répondant aux dernières évolutions des normes européennes et internationales.

"Nous sommes un acteur mondial"

We guarantee high quality products, up to date with the latest European and international standards.

"we are a global player"



ISO 9001 - ISO 14001

Nous sommes certifiés ISO 9001 depuis plus de 20 ans. Cette certification internationale garantie à nos clients l'application d'un « management de la qualité » optimal, afin de leur offrir le meilleur service. Grâce à notre système de management environnemental, nous sommes certifiés ISO 14001 ce qui traduit nos efforts en matière de protection de l'environnement.

We have been ISO 9001 certified for more than 20 years. This international certification guarantees the optimal quality of management to offer you the best service. Thanks to our environmental management system, we also have the ISO 14001 certification, which confirms our environmental protection efforts.



DIRECTIVES EUROPÉENNES

EUROPEAN DIRECTIVES

➤ **DESP** : Directive Européenne 2014/68/UE des « Equipements sous pression ».

➤ **DESP** : European Directive 2014/68/EU "Pressure Equipment Directive".

➤ **ATEX** : Directive 2014/34/UE (atmosphères explosives).

➤ **ATEX** : Directive 2014/34/EU (potentially explosive atmospheres).

➤ **Directive Machines** : 2006/42/CE.

➤ **Machinery Directive** : 2006/42/CE.

➤ **ADR** : norme EN14432, toutes nos vannes sont testées selon l'accord Européen ADR.

➤ **ADR** : EN14432, all our valves are tested in accordance to the ADR European Standard.

CERTIFICATIONS EAU WATER CERTIFICATIONS

AUTRES CERTIFICATIONS OTHER CERTIFICATIONS



TECOFI s'engage dans le mouvement FRENCH FAB pour contribuer au rayonnement de l'industrie française à l'international.

TECOFI is part of the FRENCH FAB movement to contribute to the influence of French industry worldwide.



Membres de
Members of



Nous apportons une grande importance au partage d'expérience et à l'évolution de nos métiers. Nous sommes membres de groupements professionnels spécialisés, afin de partager et rester à l'écoute des évolutions du marché de la robinetterie industrielle pour évoluer sereinement dans un environnement de plus en plus exigeant.

Being members of associations for specialized professionals allows us to share experiences, following the evolutions of the industrial valve market and seamlessly evolving in an increasingly demanding environment.

NOS MÉTIERS | OUR TRADE

CONCEPTION - BUREAU D'ÉTUDES | RESEARCH AND DESIGN OFFICE

INNOVER ET MAITRISER NOTRE PRODUCTION

En relation avec notre usine de production, notre bureau d'études reste attentif aux évolutions technologiques afin d'améliorer les produits et faire évoluer les gammes. Il propose des solutions sur mesure et s'adapte aux contraintes et demandes spécifiques des clients.

INNOVATING AND MASTERING OUR PRODUCTION

Design and Research works in connection with our production factory. Following technological advancement to improve and evolve our product ranges. Offering solutions and adapting to the needs of our clients.

CONTRÔLES QUALITÉ | QUALITY CONTROLS

Nous appliquons des procédures de contrôle qualité très rigoureuses, conformes aux spécifications internationales.

We follow rigorous quality control procedures, conforming to international specifications.

CONTRÔLES DES MATÉRIAUX
MATERIAL INSPECTIONS

TESTS D'ÉTANCHÉITÉ
HYDRAULIQUES
HYDRAULIC SEAL TESTS

CONTRÔLES DIMENSIONNELS
DIMENSIONAL CHECKS

CONTRÔLES ET ESSAIS
DE MANŒUVRE
OPERATION INSPECTIONS AND TESTS

CONTRÔLES ÉPAISSEUR PEINTURE
PAINT THICKNESS INSPECTIONS

Nouveauté 2021 : Deux nouveaux bancs de tests hydrauliques nous permettent désormais de réaliser les tests sur nos vannes à papillon du DN50 au DN1600.
Two new hydraulic test benches now allow us to perform tests on our butterfly valves from DN50 to DN1600.

Nos équipements de test nous permettent de contrôler l'étanchéité de toutes nos vannes selon la norme EN12266-1*.

NEW

Our testing equipment allows us to test all the valves seals according to the EN12266-1* standard.

**EN12266-1 : toutes nos vannes sont testées à 100% à une pression de 1,5 x PS pour le corps et 1,1 x PS pour le siège.*

All of our valves are 100% tested at a test pressure of 1.5 x PS for the body and 1.1 x PS for the seat.



CONSEIL

Nos équipes sont disponibles pour vous orienter dans vos choix afin de vous préconiser les produits les mieux adaptés à vos besoins.

GUIDANCE

Our team is available to help you choose the best products adapted to your needs.

MISE EN ROUTE COMMISSIONING

Une équipe de techniciens spécialisés assure la maintenance sur site et la formation des exploitants.

SET-UP COMMISSIONING

A team of technical specialists provides on-site maintenance and operator training.



MONTAGES ET ADAPTATIONS | ASSEMBLIES AND ADAPTATIONS

"Nous vous proposons des solutions sur mesure, adaptées à vos projets"

7 LIGNES D'ASSEMBLAGES

Les montages spécifiques sont réalisés par des spécialistes dans nos ateliers.

Adaptations et réglages de moteurs (électriques, pneumatiques), contacts fin de course...

Notre atelier assure tous vos montages en 48h ! (si stock disponible)



"We provide tailor-made solutions, adapted to each project. We are constantly evolving to meet your needs."

Seven ASSEMBLY LINES

Our specialists make specific assemblies in our workshop.

Adaptations and adjustments of motors (electric, pneumatic), limit switches...

Our workshop carries out all your assemblies in 48 hours! (if stock is available).



Vannes à boisseaux sphériques PN100 avec actionneur pneumatique double effet et commande manuelle de secours.

Ball valves PN100 with double-acting pneumatic actuators and emergency gearboxes.



Vannes à papillon équipées de vérin pneumatique double effet avec commande manuelle de secours et électrodistributeur.

Butterfly valves with double-acting pneumatic actuators, solenoid valves and emergency declutchable gearboxes.

Nous réalisons tous types d'adaptations et de montages :

Actionneurs pneumatiques, électrodistributeurs, commandes manuelles de secours, servomoteurs électriques, positionneurs, contacts fin de course, joints spéciaux ...

We do all types of adaptations and assemblies:

Pneumatic actuators, solenoid valves, emergency declutchable gearboxes, electric actuators, positioners, limit switches, specific gaskets ...

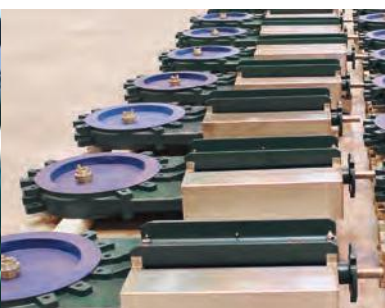

RÉFÉRENCES | REFERENCES

TECOFI - SPECIALISTE DE L'EAU & DES INDUSTRIES | TECOFI - EXPERT IN THE WATER & INDUSTRY MARKETS



Station de pompage | Eau | OUGANDA
Pumping station - Water - UGANDA



Station d'épuration | Eau | FRANCE
Wastewater treatment plant - Water - FRANCE



Désalinisation | Eau | ARABIE SAOUDITE
Desalination - Water - SAUDI ARABIA



Station de traitement des boues | FRANCE
Sewage sludge - FRANCE



Station d'épuration | Eau | BELGIQUE
Wastewater treatment plant - Water - BELGIUM



« Un partenaire top 10 grâce à l'efficacité »

« Société réactive, force de proposition et à l'écoute de son client »

“Tecofi is a regular supplier for many projects”

“We recommend Tecofi as a key supplier”



Chaufferie | HVAC | FRANCE
Boiler Room - HVAC - FRANCE



Industrie Vinicole | FRANCE
Wine Industry - FRANCE



Isolément des réseaux (Vannes Murales) | Eau | FRANCE
Network isolation (Penstocks) - Water - FRANCE



Désalinisation | Eau | EMIRATS ARABES UNIS
Desalination - Water - UAE



Biogaz | Industrie | FRANCE
Biogas - FRANCE

NOUVEAUX PRODUITS | NEW PRODUCTS

VANNE À PAPILLON GAMME VPG

VPG BUTTERFLY VALVE

p.38 > 40

Cette vanne corps fonte conçue pour le marché du génie climatique offre le meilleur rapport qualité-prix du marché !

This valve is designed for the HVAC market and offers the best value for money!



Remplace la VPE | Substitute for the VPE

VANNE À PAPILLON TECLARGE ACS

BUTTERFLY VALVE (PN10-PN16)

p.47 > 49

Découvrez notre gamme de vanne à papillon grand diamètre (DN350 à DN1200) ACS, pour vos applications sur eau potable !

Discover our range of large diameter ACS butterfly valves (DN350 to DN1200), for your drinking water applications!



ACS



TECWAT ARBRE SEC | TECWAT DRY SHAFT p.69



Grande résistance à la corrosion EN 1074 WRAS
High resistance to corrosion ACS

- ✓ Excellente étanchéité : arbre protégé par un fourreau + réducteur conforme à l'indice IP67 adapté pour le montage en pleine terre ou en immersion temporaire (-1m pendant 30min).
Excellent sealing: shaft protected by a sheath, IP67 manual gearbox. Complies with IP67 rating suitable for mounting in open ground or temporary immersion (-1m for 30min).

- ✓ Sans entretien grâce aux paliers auto-lubrifiés
Self-lubricated bearings: maintenance free

- ✓ Corps et papillon fonte ductile EN-GJS-500-7 (GGG50)
Ductile iron body and disc EN-GJS-500-7 (GGG50)

- ✓ Joint de papillon EPDM WRAS / ACS
WRAS / ACS EPDM seal

- ✓ Résistant à la corrosion :
- Boulonnerie acier Inoxydable 304
- Revêtement époxy 250µm

Corrosion resistant:
- 304 Stainless steel bolts
- 250µm epoxy coating



Étanchéité
Bi-directionnelle

- ✓ L'axe est sans jeu. Il n'est jamais en contact avec le fluide, ce qui le protège de la corrosion.
- ✓ Siège d'étanchéité encastré et maintenu par la frette en inox (soudé au-delà du DN200).
- ✓ Couple de manœuvre réduit.
- ✓ Faible perte de charge.
- ✓ Réducteur IP67.

Bi-directional sealing

- ✓ The backlash-free shaft is connected to the disc. It is never in contact with the fluid, protecting it from corrosion.
- ✓ Built-in sealing seat and held by the Stainless steel retaining ring (welded from DN200).
- ✓ Reduced operating torque.
- ✓ Low head loss.
- ✓ IP67 manual gearbox with handwheel.

Disponible du DN80 au DN1200 en stock ! In stock from DN80 to DN1200! (PN10 - PN16)



VANNE À GUILLOTINE p.97 FONTE DUCTILE EN-GJS-500-7 (GGG50)

Nouveau ! Notre gamme de vanne à guillotine évolue vers la fonte ductile, pour des vannes plus robustes et résistantes !
Découvrez notre gamme pages 97 > 104

DUCTILE IRON EN-GJS-500-7 (GGG50) KNIFE GATE VALVE

Our knife gate valves range is changing to ductile iron, to be more robust and more resistant!
Discover our range on pages 97 > 104



Résistance
mécanique

- ✓ Robuste, la fonte ductile possède des propriétés mécaniques améliorées.

Mechanical Resistance

- ✓ Robust, Ductile iron has improved mechanical properties, which permits better impact.

CLAPET DE NON RETOUR À FERMETURE RAPIDE

QUICK CLOSING NON-RETURN CHECK VALVE **p.162-163**



Clapet de haute qualité pour assurer la sécurité de vos réseaux d'eau



High quality check valve that will ensure the security of your water networks

ACS

- ✓ Limite les coups de bélier - **Excellente réponse dynamique**
Prevents water hammer - Excellent dynamic response
- ✓ Fonctionne en toutes positions d'installation : ressort inox de rappel
Use in all installation positions: Stainless steel counter spring
- ✓ Excellent comportement hydraulique : faible perte de charge
Optimum hydraulic operation: low head loss
- ✓ Manœuvre silencieuse - Absence de vibrations
Operates silently - No vibration
- ✓ Étanchéité 100% en position fermée
100% sealing in closed position
- ✓ Installation simple et absence de maintenance grâce à sa conception
Easy installation and no maintenance required due to its design
- ✓ Robuste et résistant : corps en fonte ductile GGG40 - Ressort Inox 302
*Robust and resistant: body in ductile iron GGG40
Stainless steel spring 302*

*Respect des exigences ACS / NSF - Complies with ACS / NSF requirements
DN50 - 1200 / PN10 / 16 / 25 / 40 / ASA150 / ASA300*



Conception Innovante

- ✓ Obturateur léger et de faible inertie (course limitée à 1/10ème du diamètre nominal).
- ✓ Obturateur en élastomère de polyuréthane qui absorbe les chocs.
- ✓ Face à face court : installation aisée.
- ✓ Profil hydraulique permettant un écoulement optimal.
- ✓ 1 Gamme unique : raccordement entre-brides PN10/16/25/40/ASA150/300.

Innovative Design

- ✓ Light-weight obturator with low inertia (short operation travel limited to 1/10th of nominal diameter).
- ✓ Obturator made of polyurethane to absorb the shocks.
- ✓ No mechanical spare parts.
- ✓ Hydraulic design allowing optimal flow.
- ✓ Unique range: wafer type for PN10/16/25/40/ASA150/ASA300 flanges.

ADAPTATEURS | JOINTS DE DÉMONTAGE

GAMME COMPLÈTE **p.218-221**

Conception robuste, installation aisée.
Gamme complète.

COMPLETE RANGE FLANGE ADAPTORS | COUPLINGS

Designed with strength,
ease of installation.
Full range.



COMPENSATEUR MÉTALLIQUE

FLANGE TYPE
METAL
EXPANSION JOINT

p.237



**Résistant aux
T° élevées (+427°C)**

- ✓ Diminution des contraintes mécaniques et thermiques sur les tuyauteries et les systèmes annexes.
- ✓ Absorption des mouvements axiaux de 30mm et 60mm en std.
- ✓ Idéal pour produits agressifs.

Resistant to high T°C (+427°C)

- ✓ Decrease of mechanical and thermal stress to adjoining systems (pumps, actuators, etc.).
- ✓ Absorption of axial movements (30mm and 60mm std).
- ✓ Ideal for aggressive products.

CAP SUR L'AVENIR ! FOCUS ON THE FUTURE!



Pour consolider notre développement commercial, TECOFI déménage une partie de ses collaborateurs pour un espace commun de 1500m². To strengthen our development, a part of our team has moved to a new location with 1500m² of space.

En 2019, une nouvelle Direction Générale a été mise en place. Ayant déjà fait ses preuves depuis 2 ans, l'équipe est pleine de ressources et de projets pour l'avenir. Ses objectifs : pérenniser l'activité, faire grandir le groupe et moderniser les processus. Encore de belles années à venir pour Tecofi !

In 2019, new management was put into place. Having already made its mark over the past 2 years, the team is full of motivation for the future. The goals: maintain activity, grow the group, and modernize processes. Another great year to come for Tecofi!

SUIVEZ-NOUS | FOLLOW US

Vous êtes toujours plus nombreux à nous suivre. Nous vous remercions d'être là au quotidien et sommes ravis de partager notre passion avec vous sur nos pages LinkedIn officielles* !



More and more of you are following. We thank you for being there every day and are delighted to share our passion with you on our LinkedIn pages*!

TECOFI SAS (France)
TECOFI SAS (International)

SERVICE CLIENT | CUSTOMER SERVICE

Votre satisfaction, notre priorité !

Afin de vous offrir le meilleur service, un TCHAT WhatsApp a été mis en place pour vos demandes de prix et de délais en instantanée !



WhatsApp CHAT
+33 6 23 89 87 06

Your satisfaction is our priority!

In order to offer you the best service, use our new WhatsApp CHAT for your price and delay requests.

TECOFI FRANCE

Siège social et logistique / Headquarters and logistics

83 rue Marcel Mérieux - 69960 Corbas - FRANCE

Administratif et vente / Administrative and sales offices

8 rue Joseph Nicéphore Niépce - 69740 Genas - FRANCE

T. +33 (0)4 72 79 05 79 | F. +33 (0)4 78 90 19 19

✉ sales@tecofi.fr | 🗨️ +33 623 898 706 (WhatsApp Chat)

www.tecofi.fr

MINIMUM DE COMMANDE ORDER MINIMUM



CERTIFICATS CERTIFICATES

Attestation de conformité à la commande EN10204 2.2 | Declaration of compliance with the order EN10204 2.25€

Certificat de réception EN10204 3.1
Inspection certificate EN10204 3.1.....15€
Autres sur demande | Other certificates on request

Journée de test :à partir de 1 800€
(nous consulter)
Day of testing:from 1 800€
(contact us)

ATEX SUR DEMANDE ATEX ON REQUEST

VP + BS manuels / réducteur / vérin (certificat + atelier)
Butterfly valves + Ball valves (manual/ Gearbox/ Pneumatic actuator) (certification + workshop)
DN 32/40 - 150.....15€ net HT / unit. I net EXCL.TAX
DN 200 - 300.....20€ net HT / unit. I net EXCL.TAX
DN 350 - 1200.....50€ net HT / unit. I net EXCL.TAX

VG volant / vérin (certificat + atelier)
Knife gate valves (handwheel / Pneumatic actuator) (certification + workshop)
DN 50 - 300..... 25€ net HT / unit. I net EXCL.TAX
DN 350 - 600..... 35€ net HT / unit. I net EXCL.TAX

Autres produits sur demande.
Other products on request.

HEURES D'OUVERTURE BUREAU OFFICE OPENING HOURS (GMT+1)

Lundi au jeudi : 8h - 12h / 13h30 - 17h
Monday to Thursday: from 8:00 a.m. to 12:00 p.m.
from 1:30 p.m. to 5:00 p.m.

Vendredi : 8h - 12h / 13h30 - 16h00
Friday: from 8:00 a.m. to 12:00 p.m.
from 1:00 p.m. to 4:00 p.m.

Les photos utilisées dans ce catalogue sont non contractuelles. Nous nous réservons le droit de modifier nos prix, références et visuels. The photos used in this catalogue are no contractual. We reserve the right to modify our prices, references and visuals.

INDEX



VANNE À PAPILLON
BUTTERFLY VALVE

15 > 93



VANNE À GUILLOTINE
KNIFE GATE VALVE

95 > 159



CLAPET | FILTRE
CHECK VALVE

STRAINER **161 > 193**



VANNE À PASSAGE
DIRECT | GATE VALVE

195 > 215



RACCORDEMENT ET
PROTECTION RÉSEAUX
NETWORK CONNECTION
& PROTECTION **217 > 229**



COMPENSATEUR
EXPANSION JOINT

231 > 241



ROBINET DE RÉGULATION
REGULATION VALVE

243 > 249



SOLUTIONS
D'ÉQUILIBRAGE
BALANCING SOLUTIONS

251 > 259



ROBINET À BOISSEAU
SPHÉRIQUE | BALL
VALVE **261 > 289**

COMPLÉMENT DE GAMME
ADDITIONAL RANGES



MESURE | CONTRÔLE
MEASURE | CONTROL

291 > 307



ÉLECTROVANNE
SOLENOID VALVE

309 > 313



RACCORD | BRIDE | JOINT
COUPLING | FLANGE |
GASKET

315 > 323

GUIDE TECHNIQUE | TECHNICAL BOOK **325 > 346**

La vanne à papillon notre Best-Seller

Butterfly Valve, our Best-Seller

100%

SATISFACTION

GUARANTEE



Toutes les vannes sont
fabriquées, testées et
assemblées par Tecofi

All valves are
manufactured, tested
and assembled by Tecofi



VANNE À PAPILLON BUTTERFLY VALVE

TECFLY

VPI
16 > 37



VP APPLICATIONS SPÉCIALES
BV SPECIAL APPLICATIONS
43

VPG / VPE
38 > 42



VP DOUBLE BRIDE
BV DOUBLE FLANGED
44 > 45



KIT

TECFLY
26 > 37

TECFLY +
TECLARGE
57 > 64

TECLARGE + KIT
TECLARGE & KIT
46 > 64

TECWAT + KIT
TECWAT & KIT
65 > 81



GAMME CHIMIE (PTFE)
CHEMICAL RANGE
82 > 85

GAMME GAZ
GAS RANGE
86

GAMME INDUSTRIE
INDUSTRIAL RANGE
87 > 89

CONSEILS TECHNIQUES
TECHNICAL NOTES
90 > 93

TECFLY VPI

DN 32-300 - PN16



BOULONNERIE INOX A2

Anti-corrosion
Stainless steel A2 bolts and nuts
Resistant to corrosion

POIGNÉE TECOFI TRIPLE FONCTIONS

Secteur cranté en fonte ductile EN-GJS-400-15 (axe et ressort en Inox)
10 positions, cadencassable, possibilité de régulation fine. **Résistante et légère.**
Triple-use TECOFI handle (10-position notched locking quadrant, regulation function, and lockable) in ductile iron EN-GJS-400-15 (SS spring and pin).
Resistant and lightweight.

SÉCURITÉ ANTI EJECTION DE L'AXE

Par circlips
Blowout-proof stem by circlips

PALIER REVÊTUS + PTFE

Guidage parfait de l'axe
PTFE bearing
Perfect guiding of the shaft

DOUBLE ÉTANCHÉITÉ DE L'AXE

Par joint torique
Double sealing of stem
by O-ring

CONSTRUCTION DOUBLE AXES

Papillon aminci qui réduit la perte de charge et le couple de manoeuvre
Double axis stem design
Thinner disc to lower head loss and reduce torque

AXE FACILEMENT EXTRACTIBLE

Easy disassembled stem

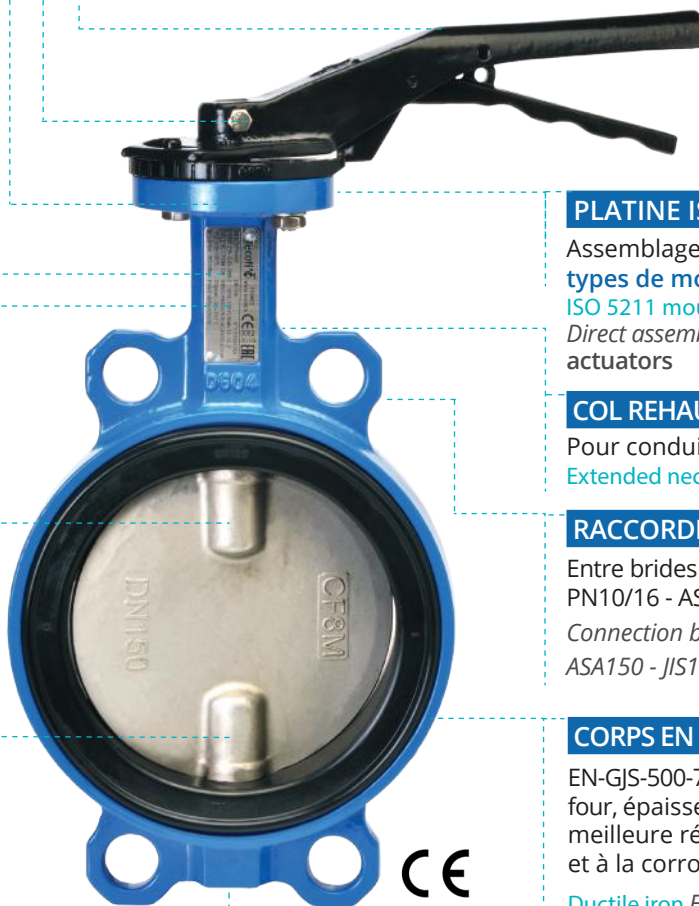

PLATINE ISO 5211

Assemblage direct avec tous types de motorisation
ISO 5211 mounting plate
Direct assembly with all types of actuators

COL REHAUSSÉ

Pour conduite calorifugée
Extended neck for insulated pipe

RACCORDEMENT

Entre brides
PN10/16 - ASA150 - JIS10K - GHOST
Connection between flanges PN10/16 ASA150 - JIS10K - GHOST

CORPS EN FONTE DUCTILE

EN-GJS-500-7 revêtu époxy, cuit au four, épaisseur mini 150µm, meilleure résistance mécanique et à la corrosion

Ductile iron EN-GJS-500-7 body epoxy coated, oven backed, with a 150µm minimum thickness, better mechanical and corrosion resistance

Conforme aux normes EN12266-1, DIN 3230, ISO 5208, CE
In accordance with EN12266-1, DIN 3230, ISO 5208, CE



Manchette à talon d'appui
➔ assure une bonne étanchéité
The seat ensures a good seal



FIABILITÉ ET MAINTENANCE OPTIMISÉE
Reliability and optimized maintenance

MANCHETTE À TALON D'APPUI REMPLAÇABLE - MEILLEURE TENUE - COUPLE RÉDUIT

Replaceable and grooved seat - Better support - Lower torque

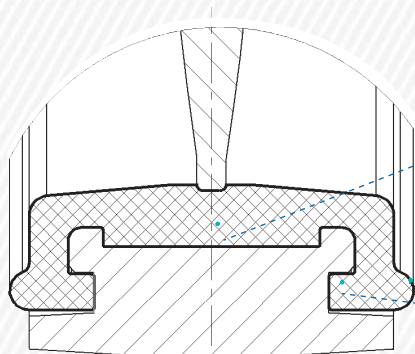

Montage sur tous types de brides [Installation on all types of flanges](#)

RENFORT de la partie centrale dans le corps qui évite tout glissement.

Reinforcement of the central part in the body, preventing any sliding.

BOSSAGES réalisés sur le diamètre extérieur de la manchette, facilitant l'étanchéité sur tous les types de brides.

Raised bosses on the outside perimeter of the sleeve, which facilitates the sealing on different types of flanges.

ERGOTS assurant un meilleur maintien entre brides.

Pin for better support between flanges.

GAMME TECFLY - DN32/40>DN300
Tecfly butterfly valves range - DN32/40>DN300

VPI / VPG disponibles en version oreilles lisses ou taraudées / Available on Wafer and Lug type

VPI



VPG*



*Evolution de gamme !
VPE jusqu'à épaisseur
Range evolution!
VPE while stocks last

VP DOUBLE BRIDE
DOUBLE FLANGED



VP APPLICATIONS SPÉCIALES
SPECIAL CONDITIONS



Version réducteur
Gearbox version



VPI4448-02

Poignée 3F | 3F Handle

Vanne à papillon wafer PN16 papillon fonte GS
Wafer type butterfly valve PN16 ductile iron disc



Corps : Fonte ductile EN-GJS-500-7 (GGG50)
Papillon : Fonte ductile EN-GJS-500-7 (GGG50)
Raccordement : Entre brides oreilles lisses PN 10/16 - ASA 150 - JIS 10K
Pression de service : EPDM CH / NBR 16 bar ; FPM / SI 10 bar

Body: Ductile iron EN-GJS-500-7 (GGG50)
Disc: Ductile iron EN-GJS-500-7 (GGG50)
Connection: Wafer Type PN 10/16 - ASA 150 - JIS 10K
Working pressure: EPDM CH / NBR 16 bar ; FPM / SI 10 bar



ATEX sur demande / ATEX on request



DN		Kg		Manchette / Seat			
mm	inch	L (mm)		EPDM CH / Heat EPDM	NBR	FPM	SILICONE
				Ref.	Ref.	Ref.	Ref.
32/40	1 1/2	32,5	2,00	VPI4448-02EP0040	VPI4448-02NI0040	VPI4448-02VI0040	VPI4448-02SI0040
50	2"	42,5	2,40	VPI4448-02EP0050	VPI4448-02NI0050	VPI4448-02VI0050	VPI4448-02SI0050
65	2 1/2	45,5	3,05	VPI4448-02EP0065	VPI4448-02NI0065	VPI4448-02VI0065	VPI4448-02SI0065
80	3"	45,5	3,60	VPI4448-02EP0080	VPI4448-02NI0080	VPI4448-02VI0080	VPI4448-02SI0080
100	4"	51,5	4,40	VPI4448-02EP0100	VPI4448-02NI0100	VPI4448-02VI0100	VPI4448-02SI0100
125	5"	55,5	6,40	VPI4448-02EP0125	VPI4448-02NI0125	VPI4448-02VI0125	VPI4448-02SI0125
150	6"	55,5	8,10	VPI4448-02EP0150	VPI4448-02NI0150	VPI4448-02VI0150	VPI4448-02SI0150
200	8"	59,5	14,20	VPI4448-02EP0200	VPI4448-02NI0200	VPI4448-02VI0200	VPI4448-02SI0200
250	10"	67,5	21,30	VPI4448-02EP0250	VPI4448-02NI0250	VPI4448-02VI0250	VPI4448-02SI0250
300	12"	77,5	28,20	VPI4448-02EP0300	VPI4448-02NI0300	VPI4448-02VI0300	VPI4448-02SI0300
				Température de service : -15°C (-30°C pointe) +130°C (+150°C pointe) Working temperature: -15°C (-30°C peak) +130°C (+150°C peak)	Température de service : -10°C (-20°C pointe) +80°C (+90°C pointe) Working temperature: -10°C (-20°C peak) +80°C (+90°C peak)	Température de service : -10°C (-20°C pointe) +150°C (+150°C pointe) Working temperature: -10°C (-20°C peak) +150°C (+150°C peak)	Température de service : -20°C (-40°C pointe) +170°C (+200°C pointe) Working temperature: -20°C (-40°C peak) +170°C (+200°C peak)

VPI4448-08

Réducteur | Gearbox

Vanne à papillon wafer PN16 papillon fonte GS

Wafer type butterfly valve PN16 ductile iron disc



CE



Corps : Fonte ductile EN-GJS-500-7 (GGG50)

Papillon : Fonte ductile EN-GJS-500-7 (GGG50)

Raccordement : Entre brides oreilles lisses PN10/16 - ASA 150 - JIS 10K

Pression de service : 16 bar

Body: Ductile iron EN-GJS-500-7 (GGG50)

Disc: Ductile iron EN-GJS-500-7 (GGG50)

Connection: Wafer Type PN10/16 - ASA 150 - JIS 10K

Working pressure: 16 bar



ATEX sur demande / on request

**Montage possible sur colonnette droite et murale.** Voir pages 28-29**Valve adapted for pedestal floor and wall mounting.** See on pages 28-29**Réducteur mécanique et options pages 26-27**
Mechanical gearbox and options on pages 26-27

Les volants sont livrés démontés pour l'optimisation de l'envoi. Nous vous invitons à spécifier le montage du volant lors de votre commande si impératif (coût de montage en sus).

Handwheels are delivered disassembled for the optimization of the shipment.

Please contact us if it is imperative that the valve is shipped with handwheel assembled.

Température de service :
-15°C (-30°C pointe)
+130°C (+150°C pointe)Working temperature:
-15°C (-30°C peak)
+130°C (+150°C peak)Température de service :
-10°C (-20°C pointe)
+80°C (+90°C pointe)Working temperature:
-10°C (-20°C peak)
+80°C (+90°C peak)

VPI4448-N03 | VPI4448-N07

Vérin | Actuator

Vanne à papillon wafer PN16 papillon fonte GS

Wafer type butterfly valve PN16 ductile iron disc



CE

Modèle N03 (DE)
Model N03 (DA)

Corps : Fonte ductile EN-GJS-500-7 (GGG50)

Papillon : Fonte ductile EN-GJS-500-7 (GGG50)

Raccordement : Entre brides oreilles lisses PN10/16 - ASA 150 - JIS 10K

Pression de service : 16 bar

ΔP 16 bar



ATEX sur demande / ATEX on request

Body: Ductile iron EN-GJS-500-7 (GGG50)

Disc: Ductile iron EN-GJS-500-7 (GGG50)

Connection: Wafer Type PN10/16 - ASA 150 - JIS 10K

Working pressure: 16 bar

ΔP 16 bar

**Vérin pneumatique seul pages 36-37**
Pneumatic actuator on pages 36-37

DN		L (mm)	Manchette / Seat					
mm	inch		EPDM CH / Heat EPDM		NBR			
			Double effet / Double-Acting	Simple effet / Single-Acting	Double effet / Double-Acting	Simple effet / Single-Acting		
Ref.	Kg	Ref.	Kg	Ref.	Ref.			
32/40	1"1/2	32,5	VPI4448-N03EP0040	3,1	VPI4448-N07EP0040	3,8	VPI4448-N03NI0040	VPI4448-N07NI0040
50	2"	42,5	VPI4448-N03EP0050	3,7	VPI4448-N07EP0050	4,4	VPI4448-N03NI0050	VPI4448-N07NI0050
65	2"1/2	45,5	VPI4448-N03EP0065	4,7	VPI4448-N07EP0065	6,3	VPI4448-N03NI0065	VPI4448-N07NI0065
80	3"	45,5	VPI4448-N03EP0080	5,1	VPI4448-N07EP0080	8,3	VPI4448-N03NI0080	VPI4448-N07NI0080
100	4"	51,5	VPI4448-N03EP0100	7,1	VPI4448-N07EP0100	10,8	VPI4448-N03NI0100	VPI4448-N07NI0100
125	5"	55,5	VPI4448-N03EP0125	9,1	VPI4448-N07EP0125	16,1	VPI4448-N03NI0125	VPI4448-N07NI0125
150	6"	55,5	VPI4448-N03EP0150	12,0	VPI4448-N07EP0150	25,0	VPI4448-N03NI0150	VPI4448-N07NI0150
200	8"	59,5	VPI4448-N03EP0200	21,8	VPI4448-N07EP0200	37,0	VPI4448-N03NI0200	VPI4448-N07NI0200
250	10"	67,5	VPI4448-N03EP0250	32,4	VPI4448-N07EP0250	57,4	VPI4448-N03NI0250	VPI4448-N07NI0250
300	12"	77,5	VPI4448-N03EP0300	47,3	VPI4448-N07EP0300	85,0	VPI4448-N03NI0300	VPI4448-N07NI0300
			Température de service : -15°C (-30°C pointe) / +130°C (+150°C pointe)			Température de service : -10°C (-20°C pointe) / +80°C (+90°C pointe)		
			Working temperature: -15°C (-30°C peak) / +130°C (+150°C peak)			Working temperature: -10°C (-20°C peak) / +80°C (+90°C peak)		





VPI4449-02

Poignée 3F | 3F Handle

Vanne à papillon wafer PN16 papillon inox
Wafer type butterfly valve PN16 Stainless steel disc



Corps : Fonte ductile EN-GJS-500-7 (GGG50)
Papillon : Inox CF8M (Inox 316)
Raccordement : Entre brides oreilles lisses PN10/16 - ASA 150 - JIS 10K
Pression de service : EPDM CH / NBR 16 bar ; FPM / SI 10 bar

Body: Ductile iron EN-GJS-500-7 (GGG50)
Disc: Stainless steel CF8M (AISI 316)
Connection: Wafer Type PN10/16 - ASA 150 - JIS 10K
Working pressure: EPDM CH / NBR 16 bar ; FPM / SI 10 bar



ATEX sur demande / ATEX on request



DN		Kg		Manchette / Seat			
mm	inch	L (mm)		EPDM CH / Heat EPDM	NBR	FPM	SILICONE
				Ref.	Ref.	Ref.	Ref.
32/40	1"1/2	32,5	2,00	VPI4449-02EP0040	VPI4449-02NI0040	VPI4449-02VI0040	VPI4449-02SI0040
50	2"	42,5	2,40	VPI4449-02EP0050	VPI4449-02NI0050	VPI4449-02VI0050	VPI4449-02SI0050
65	2"1/2	45,5	3,05	VPI4449-02EP0065	VPI4449-02NI0065	VPI4449-02VI0065	VPI4449-02SI0065
80	3"	45,5	3,60	VPI4449-02EP0080	VPI4449-02NI0080	VPI4449-02VI0080	VPI4449-02SI0080
100	4"	51,5	4,40	VPI4449-02EP0100	VPI4449-02NI0100	VPI4449-02VI0100	VPI4449-02SI0100
125	5"	55,5	6,40	VPI4449-02EP0125	VPI4449-02NI0125	VPI4449-02VI0125	VPI4449-02SI0125
150	6"	55,5	8,10	VPI4449-02EP0150	VPI4449-02NI0150	VPI4449-02VI0150	VPI4449-02SI0150
200	8"	59,5	14,20	VPI4449-02EP0200	VPI4449-02NI0200	VPI4449-02VI0200	VPI4449-02SI0200
250	10"	67,5	21,30	VPI4449-02EP0250	VPI4449-02NI0250	VPI4449-02VI0250	VPI4449-02SI0250
300	12"	77,5	28,20	VPI4449-02EP0300	VPI4449-02NI0300	VPI4449-02VI0300	VPI4449-02SI0300

Température de service :	Température de service :	Température de service :	Température de service :
-15°C (-30°C pointe) +130°C (+150°C pointe)	-10°C (-20°C pointe) +80°C (+90°C pointe)	-10°C (-20°C pointe) +150°C (+150°C pointe)	-20°C (-40°C pointe) +170°C (+200°C pointe)
Working temperature: -15°C (-30°C peak) +130°C (+150°C peak)	Working temperature: -10°C (-20°C peak) +80°C (+90°C peak)	Working temperature: -10°C (-20°C peak) +150°C (+150°C peak)	Working temperature: -20°C (-40°C peak) +170°C (+200°C peak)



Optez pour la version WRAS / ACS, pour vos applications sur eau potable !
Order WRAS/ACS versions for your drinking water applications!



Température de service : -15°C + 85°C
Working temperature: -15°C + 85°C

DN		Kg		Manchette / Seat
mm	inch	L (mm)		EPDM WRAS / ACS
				Ref.
32/40	1"1/2	32,5	2,00	VPI4449-02EPA0040
50	2"	42,5	2,40	VPI4449-02EPA0050
65	2"1/2	45,5	3,05	VPI4449-02EPA0065
80	3"	45,5	3,60	VPI4449-02EPA0080
100	4"	51,5	4,40	VPI4449-02EPA0100
125	5"	55,5	6,40	VPI4449-02EPA0125
150	6"	55,5	8,10	VPI4449-02EPA0150
200	8"	59,5	14,20	VPI4449-02EPA0200
250	10"	67,5	21,30	VPI4449-02EPA0250
300	12"	77,5	28,20	VPI4449-02EPA0300



VPI4449-08

Réducteur | Gearbox

Vanne à papillon wafer PN16 papillon inox

Wafer type butterfly valve PN16 Stainless steel disc



CE



Corps : Fonte ductile EN-GJS-500-7 (GGG50)

Papillon : Inox CF8M (Inox 316)

Raccordement : Entre brides oreilles lisses PN10/16 - ASA 150 - JIS 10K

Pression de service : 16 bar

Body : Ductile iron EN-GJS-500-7 (GGG50)

Disc : Stainless steel CF8M (AISI 316)

Connection : Wafer Type PN10/16 - ASA 150 - JIS 10K

Working pressure: 16 bar



ATEX sur demande / on request

DN		L (mm)	Kg
mm	inch		
32/40	1"1/2	32,5	5,30
50	2"	42,5	5,70
65	2"1/2	45,5	6,35
80	3"	45,5	6,90
100	4"	51,5	7,70
125	5"	55,5	9,80
150	6"	55,5	11,50
200	8"	59,5	23,20
250	10"	67,5	30,30
300	12"	77,5	37,20

Manchette / Seat

EPDM CH / Heat EPDM		NBR	
Ref.		Ref.	
VPI4449-08EP0040	VPI4449-08NI0040		
VPI4449-08EP0050	VPI4449-08NI0050		
VPI4449-08EP0065	VPI4449-08NI0065		
VPI4449-08EP0080	VPI4449-08NI0080		
VPI4449-08EP0100	VPI4449-08NI0100		
VPI4449-08EP0125	VPI4449-08NI0125		
VPI4449-08EP0150	VPI4449-08NI0150		
VPI4449-08EP0200	VPI4449-08NI0200		
VPI4449-08EP0250	VPI4449-08NI0250		
VPI4449-08EP0300	VPI4449-08NI0300		

Température de service : -15°C (-30°C pointe) / +130°C (+150°C pointe)	Température de service : -10°C (-20°C pointe) / +80°C (+90°C pointe)
Working temperature: -15°C (-30°C peak) / +130°C (+150°C peak)	Working temperature: -10°C (-20°C peak) / +80°C (+90°C peak)



Montage possible sur colonnette droite et murale. Voir pages 28-29

Valve adapted for pedestal floor and wall mounting. See on pages 28-29

Réducteur mécanique et options pages 26-27
Mechanical gearbox and options on pages 26-27Les volants sont livrés démontés pour l'optimisation de l'envoi. Nous vous invitons à spécifier le montage du volant lors de votre commande si impératif (coût de montage en sus).
Handwheels are delivered disassembled for the optimization of the shipment.
Please contact us if it is imperative that the valve is shipped with handwheel assembled.

VPI4449-N03 | VPI4449-N07

Vérin | Actuator

Vanne à papillon wafer PN16 papillon inox

Wafer type butterfly valve PN16 Stainless steel disc



CE

Modèle N07 (SE)
Model N07 (SA)

Corps : Fonte ductile EN-GJS-500-7 (GGG50)

Papillon : Inox CF8M

Raccordement : Entre brides oreilles lisses PN10/16 - ASA 150 - JIS 10K

Pression de service : 16 bar

ΔP 16 bar



ATEX sur demande / ATEX on request

Body : Ductile iron EN-GJS-500-7 (GGG50)

Disc : Stainless steel CF8M

Connection : Wafer Type PN10/16 - ASA 150 - JIS 10K

Working pressure: 16 bar

ΔP 16 bar

Vérin pneumatique seul pages 36-37
Pneumatic actuator on pages 36-37

Manchette / Seat

DN		L (mm)	EPDM CH / Heat EPDM				NBR	
mm	inch		Double effet / Double-Acting		Simple effet / Single-Acting		Double effet / Double-Acting	
			Ref.	Kg	Ref.	Kg	Ref.	Ref.
32/40	1"1/2	32,5	VPI4449-N03EP0040	3,1	VPI4449-N07EP0040	3,8	VPI4449-N03NI0040	VPI4449-N07NI0040
50	2"	42,5	VPI4449-N03EP0050	3,7	VPI4449-N07EP0050	4,4	VPI4449-N03NI0050	VPI4449-N07NI0050
65	2"1/2	45,5	VPI4449-N03EP0065	4,7	VPI4449-N07EP0065	6,3	VPI4449-N03NI0065	VPI4449-N07NI0065
80	3"	45,5	VPI4449-N03EP0080	5,1	VPI4449-N07EP0080	8,3	VPI4449-N03NI0080	VPI4449-N07NI0080
100	4"	51,5	VPI4449-N03EP0100	7,1	VPI4449-N07EP0100	10,8	VPI4449-N03NI0100	VPI4449-N07NI0100
125	5"	55,5	VPI4449-N03EP0125	9,1	VPI4449-N07EP0125	16,1	VPI4449-N03NI0125	VPI4449-N07NI0125
150	6"	55,5	VPI4449-N03EP0150	12,0	VPI4449-N07EP0150	25,0	VPI4449-N03NI0150	VPI4449-N07NI0150
200	8"	59,5	VPI4449-N03EP0200	21,8	VPI4449-N07EP0200	37,0	VPI4449-N03NI0200	VPI4449-N07NI0200
250	10"	67,5	VPI4449-N03EP0250	32,4	VPI4449-N07EP0250	57,4	VPI4449-N03NI0250	VPI4449-N07NI0250
300	12"	77,5	VPI4449-N03EP0300	47,3	VPI4449-N07EP0300	85,0	VPI4449-N03NI0300	VPI4449-N07NI0300

Température de service : -15°C (-30°C pointe) / +130°C (+150°C pointe)	Température de service : -10°C (-20°C pointe) / +80°C (+90°C pointe)
Working temperature: -15°C (-30°C peak) / +130°C (+150°C peak)	Working temperature: -10°C (-20°C peak) / +80°C (+90°C peak)





VPI4648-02

Poignée 3F | 3F Handle

Vanne à papillon oreilles taraudées PN16 papillon fonte GS
Lug type butterfly valve PN16 ductile iron disc



Corps : Fonte ductile EN-GJS-500-7 (GGG50)
Papillon : Fonte ductile EN-GJS-500-7 (GGG50)
Raccordement : Entre brides oreilles taraudées PN10 et PN16
Pression de service : EPDM CH / NBR 16 bar ; FPM / SI 10 bar

Body: Ductile iron EN-GJS-500-7 (GGG50)
Disc: Ductile iron EN-GJS-500-7 (GGG50)
Connection: Lug Type PN10 and PN16
Working pressure: EPDM CH / NBR 16 bar ; FPM / SI 10 bar



ATEX sur demande / ATEX on request



DN		PN	L (mm)	Kg	Manchette / Seat			
mm	inch				EPDM CH / Heat EPDM	NBR	FPM	SILICONE
					Ref.	Ref.	Ref.	Ref.
40	1 1/2	16	32,5	2,50	VPI4648-02EP0040	VPI4648-02NI0040	VPI4648-02VI0040	VPI4648-02SI0040
50	2"	16	42,5	3,10	VPI4648-02EP0050	VPI4648-02NI0050	VPI4648-02VI0050	VPI4648-02SI0050
65	2 1/2	16	45,5	3,70	VPI4648-02EP0065	VPI4648-02NI0065	VPI4648-02VI0065	VPI4648-02SI0065
80	3"	16	45,5	4,90	VPI4648-02EP0080	VPI4648-02NI0080	VPI4648-02VI0080	VPI4648-02SI0080
100	4"	16	51,5	6,00	VPI4648-02EP0100	VPI4648-02NI0100	VPI4648-02VI0100	VPI4648-02SI0100
125	5"	16	55,5	9,40	VPI4648-02EP0125	VPI4648-02NI0125	VPI4648-02VI0125	VPI4648-02SI0125
150	6"	16	55,5	10,50	VPI4648-02EP0150	VPI4648-02NI0150	VPI4648-02VI0150	VPI4648-02SI0150
200	8"	10 16	59,5	20,70	VPI4648-02EP0200 VPI464816-02EP0200	VPI4648-02NI0200 VPI464816-02NI0200	VPI4648-02VI0200 VPI464816-02VI0200	VPI4648-02SI0200 VPI464816-02SI0200
250	10"	10 16	67,5	27,80	VPI4648-02EP0250 VPI464816-02EP0250	VPI4648-02NI0250 VPI464816-02NI0250	VPI4648-02VI0250 VPI464816-02VI0250	VPI4648-02SI0250 VPI464816-02SI0250
300	12"	10 16	77,5	35,60	VPI4648-02EP0300 VPI464816-02EP0300	VPI4648-02NI0300 VPI464816-02NI0300	VPI4648-02VI0300 VPI464816-02VI0300	VPI4648-02SI0300 VPI464816-02SI0300
					Température de service : -15°C (-30°C pointe) +130°C (+150°C pointe) Working temperature: -15°C (-30°C peak) +130°C (+150°C peak)	Température de service : -10°C (-20°C pointe) +80°C (+90°C pointe) Working temperature: -10°C (-20°C peak) +80°C (+90°C peak)	Température de service : -10°C (-20°C pointe) +150°C (+150°C pointe) Working temperature: -10°C (-20°C peak) +150°C (+150°C peak)	Température de service : -20°C (-40°C pointe) +170°C (+200°C pointe) Working temperature: -20°C (-40°C peak) +170°C (+200°C peak)

VPI4648-08

Réducteur | Gearbox

Vanne à papillon oreilles taraudées PN16 papillon fonte GS
Lug type butterfly valve PN16 ductile iron disc



Corps : Fonte ductile EN-GJS-500-7 (GGG50)
Papillon : Fonte ductile EN-GJS-500-7 (GGG50)
Raccordement : Entre brides oreilles taraudées PN10 et PN16
Pression de service : 16 bar

Body: Ductile iron EN-GJS-500-7 (GGG50)
Disc: Ductile iron EN-GJS-500-7 (GGG50)
Connection: Lug Type PN10 and PN16
Working pressure: 16 bar



ATEX sur demande / on request



DN		PN	L (mm)	Kg	Manchette / Seat	
mm	inch				EPDM CH / Heat EPDM	NBR
					Ref.	Ref.
40	1 1/2	16	32,5	4,93	VPI4648-08EP0040	VPI4648-08NI0040
50	2"	16	42,5	5,53	VPI4648-08EP0050	VPI4648-08NI0050
65	2 1/2	16	45,5	6,10	VPI4648-08EP0065	VPI4648-08NI0065
80	3"	16	45,5	7,30	VPI4648-08EP0080	VPI4648-08NI0080
100	4"	16	51,5	8,40	VPI4648-08EP0100	VPI4648-08NI0100
125	5"	16	55,5	11,80	VPI4648-08EP0125	VPI4648-08NI0125
150	6"	16	55,5	12,90	VPI4648-08EP0150	VPI4648-08NI0150
200	8"	10 16	59,5	23,02	VPI4648-08EP0200 VPI464816-08EP0200	VPI4648-08NI0200 VPI464816-08NI0200
250	10"	10 16	67,5	30,12	VPI4648-08EP0250 VPI464816-08EP0250	VPI4648-08NI0250 VPI464816-08NI0250
300	12"	10 16	77,5	37,92	VPI4648-08EP0300 VPI464816-08EP0300	VPI4648-08NI0300 VPI464816-08NI0300
					Température de service : -15°C (-30°C pointe) +130°C (+150°C pointe) Working temperature: -15°C (-30°C peak) +130°C (+150°C peak)	Température de service : -10°C (-20°C pointe) +80°C (+90°C pointe) Working temperature: -10°C (-20°C peak) +80°C (+90°C peak)



Vanne adaptée aux montages avec colonnette droite et murale. Voir pages 28-29
Valve adapted for pedestal floor and wall mounting. See on pages 28-29



Les volants sont livrés démontés pour l'optimisation de l'envoi. Nous vous invitons à spécifier le montage du volant lors de votre commande si impératif (coût de montage en sus).
Handwheels are delivered disassembled for the optimization of the shipment. Please contact us if it is imperative that the valve is shipped with handwheel assembled.



Réducteur mécanique et options pages 26-27
Mechanical gearbox and options on pages 26-27

VPI4648-N03 | VPI4648-N07

Vérin | Actuator

Vanne à papillon oreilles taraudées PN16 papillon fonte GS

Lug type butterfly valve PN16 ductile iron disc



Corps : Fonte ductile EN-GJS-500-7 (GGG50)
Papillon : Fonte ductile EN-GJS-500-7 (GGG50)
Raccordement : Entre brides oreilles taraudées PN10 et PN16
Pression de service : 16 bar
 ΔP 16 bar

Body: Ductile iron EN-GJS-500-7 (GGG50)
Disc: Ductile iron EN-GJS-500-7 (GGG50)
Connection: Lug Type PN10 and PN16
Working pressure: 16 bar
 ΔP 16 bar



ATEX sur demande / ATEX on request



Vérin pneumatique seul pages 36-37
Pneumatic actuator pages 36-37

CE

DN		PN	L (mm)	Manchette / Seat					
mm	inch			EPDM CH / Heat EPDM		NBR			
				Double effet / Double-Acting	Simple effet / Single-Acting	Double effet / Double-Acting	Simple effet / Single-Acting		
				Ref.	Kg	Ref.	Ref.		
40	1 1/2	16	32,5	VPI4648-N03EP0040	3,5	VPI4648-N07EP0040	4,2	VPI4648-N03NI0040	VPI4648-N07NI0040
50	2"	16	42,5	VPI4648-N03EP0050	4,1	VPI4648-N07EP0050	4,8	VPI4648-N03NI0050	VPI4648-N07NI0050
65	2 1/2	16	45,5	VPI4648-N03EP0065	5,4	VPI4648-N07EP0065	7,0	VPI4648-N03NI0065	VPI4648-N07NI0065
80	3"	16	45,5	VPI4648-N03EP0080	6,5	VPI4648-N07EP0080	9,7	VPI4648-N03NI0080	VPI4648-N07NI0080
100	4"	16	51,5	VPI4648-N03EP0100	8,7	VPI4648-N07EP0100	12,4	VPI4648-N03NI0100	VPI4648-N07NI0100
125	5"	16	55,5	VPI4648-N03EP0125	12,2	VPI4648-N07EP0125	19,2	VPI4648-N03NI0125	VPI4648-N07NI0125
150	6"	16	55,5	VPI4648-N03EP0150	14,8	VPI4648-N07EP0150	27,8	VPI4648-N03NI0150	VPI4648-N07NI0150
200	8"	10	59,5	VPI4648-N03EP0200	28,4	VPI4648-N07EP0200	43,6	VPI4648-N03NI0200	VPI4648-N07NI0200
		16		VPI464816-N03EP0200		VPI464816-N07EP0200		VPI464816-N03NI0200	VPI464816-N07NI0200
250	10"	10	67,5	VPI4648-N03EP0250	40,2	VPI4648-N07EP0250	65,2	VPI4648-N03NI0250	VPI4648-N07NI0250
		16		VPI464816-N03EP0250		VPI464816-N07EP0250		VPI464816-N03NI0250	VPI464816-N07NI0250
300	12"	10	77,5	VPI4648-N03EP0300	56,4	VPI4648-N07EP0300	94,1	VPI4648-N03NI0300	VPI4648-N07NI0300
		16		VPI464816-N03EP0300		VPI464816-N07EP0300		VPI464816-N03NI0300	VPI464816-N07NI0300
				Température de service : -15°C (-30°C pointe) / +130°C (+150°C pointe)				Température de service : -10°C (-20°C pointe) / +80°C (+90°C pointe)	
				Working temperature: -15°C (-30°C peak) / +130°C (+150°C peak)				Working temperature: -10°C (-20°C peak) / +80°C (+90°C peak)	



Montage en bout de ligne possible avec une contre-bride. Veuillez à serrer les boulons opposés en même temps et en croix.

End-of-line mounting possible with a flange. Make sure to tighten crosswise the opposite bolts at the same time.





VPI4649-02

Poignée 3F | 3F Handle

Vanne à papillon oreilles taraudées PN16 papillon inox
Lug type butterfly valve PN16 Stainless steel disc



Corps : Fonte ductile EN-GJS-500-7 (GGG50)
Papillon : Inox CF8M (Inox 316)
Raccordement : Entre brides oreilles taraudées PN10 et PN16
Pression de service : EPDM CH / NBR 16 bar ; FPM / SI 10 bar

Body: Ductile iron EN-GJS-500-7 (GGG50)
Disc: Stainless steel CF8M (AISI 316)
Connection: Lug Type PN10 and PN16
Working pressure: EPDM CH / NBR 16 bar ; FPM / SI 10 bar



ATEX sur demande / ATEX on request



DN		PN	L (mm)	Kg	Manchette / Seat			
mm	inch				EPDM CH / Heat EPDM	NBR	FPM	SILICONE
					Ref.	Ref.	Ref.	Ref.
40	1 1/2	16	32,5	2,50	VPI4649-02EP0040	VPI4649-02NI0040	VPI4649-02VI0040	VPI4649-02SI0040
50	2"	16	42,5	3,10	VPI4649-02EP0050	VPI4649-02NI0050	VPI4649-02VI0050	VPI4649-02SI0050
65	2 1/2	16	45,5	3,70	VPI4649-02EP0065	VPI4649-02NI0065	VPI4649-02VI0065	VPI4649-02SI0065
80	3"	16	45,5	4,90	VPI4649-02EP0080	VPI4649-02NI0080	VPI4649-02VI0080	VPI4649-02SI0080
100	4"	16	51,5	6,00	VPI4649-02EP0100	VPI4649-02NI0100	VPI4649-02VI0100	VPI4649-02SI0100
125	5"	16	55,5	9,40	VPI4649-02EP0125	VPI4649-02NI0125	VPI4649-02VI0125	VPI4649-02SI0125
150	6"	16	55,5	10,50	VPI4649-02EP0150	VPI4649-02NI0150	VPI4649-02VI0150	VPI4649-02SI0150
200	8"	10	59,5	20,70	VPI4649-02EP0200	VPI4649-02NI0200	VPI4649-02VI0200	VPI4649-02SI0200
		16			VPI464916-02EP0200	VPI464916-02NI0200	VPI464916-02VI0200	VPI464916-02SI0200
250	10"	10	67,5	27,80	VPI4649-02EP0250	VPI4649-02NI0250	VPI4649-02VI0250	VPI4649-02SI0250
		16			VPI464916-02EP0250	VPI464916-02NI0250	VPI464916-02VI0250	VPI464916-02SI0250
300	12"	10	77,5	35,60	VPI4649-02EP0300	VPI4649-02NI0300	VPI4649-02VI0300	VPI4649-02SI0300
		16			VPI464916-02EP0300	VPI464916-02NI0300	VPI464916-02VI0300	VPI464916-02SI0300

Température de service :
-15°C (-30°C pointe)
+130°C (+150°C pointe)

Working temperature:
-15°C (-30°C peak)
+130°C (+150°C peak)

Température de service :
-10°C (-20°C pointe)
+80°C (+90°C pointe)

Working temperature:
-10°C (-20°C peak)
+80°C (+90°C peak)

Température de service :
-10°C (-20°C pointe)
+150°C (+150°C pointe)

Working temperature:
-10°C (-20°C peak)
+150°C (+150°C peak)

Température de service :
-20°C (-40°C pointe)
+170°C (+200°C pointe)

Working temperature:
-20°C (-40°C peak)
+170°C (+200°C peak)



Optez pour la version WRAS / ACS,
pour vos applications sur eau potable !

Order WRAS/ACS versions for your drinking water applications!



Température de service : -15°C + 85°C
Working temperature: -15°C + 85°C

DN		PN	L (mm)	Kg	Manchette / Seat
mm	inch				EPDM WRAS / ACS
					Ref.
40	1 1/2	16	32,5	2,50	VPI4649-02EPA0040
50	2"	16	42,5	3,10	VPI4649-02EPA0050
65	2 1/2	16	45,5	3,70	VPI4649-02EPA0065
80	3"	16	45,5	4,90	VPI4649-02EPA0080
100	4"	16	51,5	6,00	VPI4649-02EPA0100
125	5"	16	55,5	9,40	VPI4649-02EPA0125
150	6"	16	55,5	10,50	VPI4649-02EPA0150
200	8"	10	59,5	20,70	VPI4649-02EPA0200
		16			VPI464916-02EPA0200
250	10"	10	67,5	27,80	VPI4649-02EPA0250
		16			VPI464916-02EPA0250
300	12"	10	77,5	35,60	VPI4649-02EPA0300
		16			VPI464916-02EPA0300



VPI4649-08

Réducteur | Gearbox

Vanne à papillon oreilles taraudées PN16 papillon inox
Lug type butterfly valve PN16 [Stainless steel disc](#)



Corps : Fonte ductile EN-GJS-500-7 (GGG50)
Papillon : Inox CF8M (Inox 316)
Raccordement : Entre brides oreilles taraudées PN10 et PN16
Pression de service : 16 bar

Body: Ductile iron EN-GJS-500-7 (GGG50)
Disc: Stainless steel CF8M (AISI 316)
Connection: Lug Type PN10 and PN16
Working pressure: 16 bar

CE



ATEX sur demande / on request

DN		PN	L (mm)	Kg	Manchette / Seat	
mm	inch				EPDM CH / Heat EPDM	NBR
				Ref.	Ref.	
40	1"1/2	16	32,5	4,93	VPI4649-08EP0040	VPI4649-08NI0040
50	2"	16	42,5	5,53	VPI4649-08EP0050	VPI4649-08NI0050
65	2"1/2	16	45,5	6,1	VPI4649-08EP0065	VPI4649-08NI0065
80	3"	16	45,5	7,3	VPI4649-08EP0080	VPI4649-08NI0080
100	4"	16	51,5	8,4	VPI4649-08EP0100	VPI4649-08NI0100
125	5"	16	55,5	11,8	VPI4649-08EP0125	VPI4649-08NI0125
150	6"	16	55,5	12,9	VPI4649-08EP0150	VPI4649-08NI0150
200	8"	10 16	59,5	23,02	VPI4649-08EP0200 VPI464916-08EP0200	VPI4649-08NI0200 VPI464916-08NI0200
250	10"	10 16	67,5	30,12	VPI4649-08EP0250 VPI464916-08EP0250	VPI4649-08NI0250 VPI464916-08NI0250
300	12"	10 16	77,5	37,92	VPI4649-08EP0300 VPI464916-08EP0300	VPI4649-08NI0300 VPI464916-08NI0300

Température de service :
-15°C (-30°C pointe)
+130°C (+150°C pointe)

Working temperature:
-15°C (-30°C peak)
+130°C (+150°C peak)

Température de service :
-10°C (-20°C pointe)
+80°C (+90°C pointe)

Working temperature:
-10°C (-20°C peak)
+80°C (+90°C peak)



Montage possible sur colonnette droite et murale. Voir pages 28-29

Valve adapted for pedestal floor and wall mounting. See on pages 28-29



Réducteur mécanique et options pages 26-27
Mechanical gearbox and options on pages 26-27



Les volants sont livrés démontés pour l'optimisation de l'envoi. Nous vous invitons à spécifier le montage du volant lors de votre commande si impératif (coût de montage en sus).

Handwheels are delivered disassembled for the optimization of the shipment.

Please contact us if it is imperative that the valve is shipped with handwheel assembled.

VPI4649-N03 | VPI4649-N07

Vérin | Actuator

Vanne à papillon oreilles taraudées PN16 papillon inox
Lug type butterfly valve PN16 [Stainless steel disc](#)



Corps : Fonte ductile EN-GJS-500-7 (GGG50)
Papillon : Inox CF8M
Raccordement : Entre brides oreilles taraudées PN10 et PN16
Pression de service : 16 bar
 ΔP 16 bar

Body: Ductile iron EN-GJS-500-7 (GGG50)
Disc: Stainless steel CF8M
Connection: Lug Type PN10 and PN16
Working pressure: 16 bar
 ΔP 16 bar



ATEX sur demande / ATEX on request



Vérin pneumatique seul pages 36-37
Pneumatic actuator pages 36-37

CE

DN		PN	L (mm)	EPDM CH / Heat EPDM				NBR	
mm	inch			Double effet / Double-Acting		Simple effet / Single-Acting		Double effet / Double-Acting	Simple effet / Single-Acting
		Ref.		Kg		Ref.		Ref.	
40	1"1/2	16	32,5	VPI4649-N03EP0040	3,5	VPI4649-N07EP0040	4,2	VPI4649-N03NI0040	VPI4649-N07NI0040
50	2"	16	42,5	VPI4649-N03EP0050	4,1	VPI4649-N07EP0050	4,8	VPI4649-N03NI0050	VPI4649-N07NI0050
65	2"1/2	16	45,5	VPI4649-N03EP0065	5,4	VPI4649-N07EP0065	7,0	VPI4649-N03NI0065	VPI4649-N07NI0065
80	3"	16	45,5	VPI4649-N03EP0080	6,5	VPI4649-N07EP0080	9,7	VPI4649-N03NI0080	VPI4649-N07NI0080
100	4"	16	51,5	VPI4649-N03EP0100	8,7	VPI4649-N07EP0100	12,4	VPI4649-N03NI0100	VPI4649-N07NI0100
125	5"	16	55,5	VPI4649-N03EP0125	12,2	VPI4649-N07EP0125	19,2	VPI4649-N03NI0125	VPI4649-N07NI0125
150	6"	16	55,5	VPI4649-N03EP0150	14,8	VPI4649-N07EP0150	27,8	VPI4649-N03NI0150	VPI4649-N07NI0150
200	8"	10 16	59,5	VPI4649-N03EP0200 VPI464916-N03EP0200	28,4	VPI4649-N07EP0200 VPI464916-N07EP0200	43,6	VPI4649-N03NI0200 VPI464916-N03NI0200	VPI4649-N07NI0200 VPI464916-N07NI0200
250	10"	10 16	67,5	VPI4649-N03EP0250 VPI464916-N03EP0250	40,2	VPI4649-N07EP0250 VPI464916-N07EP0250	65,2	VPI4649-N03NI0250 VPI464916-N03NI0250	VPI4649-N07NI0250 VPI464916-N07NI0250
300	12"	10 16	77,5	VPI4649-N03EP0300 VPI464916-N03EP0300	56,4	VPI4649-N07EP0300 VPI464916-N07EP0300	94,1	VPI4649-N03NI0300 VPI464916-N03NI0300	VPI4649-N07NI0300 VPI464916-N07NI0300

Température de service :
-15°C (-30°C pointe) / +130°C (+150°C pointe)

Working temperature:
-15°C (-30°C peak) / +130°C (+150°C peak)

Température de service :
-10°C (-20°C pointe) / +80°C (+90°C pointe)

Working temperature:
-10°C (-20°C peak) / +80°C (+90°C peak)





Idéal eau de mer
Ideal for sea water



Bronze d'aluminium
Aluminium bronze



Entre Brides
Wafer

VPI4442-02

Poignée 3F | 3F Handle

Vanne à papillon wafer PN16 papillon bronze d'aluminium
Wafer type butterfly valve PN16 aluminium bronze disc



Corps : Fonte ductile EN-GJS-500-7 (GGG50)
Papillon : Cu Al10 Ni5 Fe4
Raccordement : Entre brides oreilles lisses
PN10/16 - ASA 150 - JIS 10K
Pression de service : 16 bar

Body: Ductile iron EN-GJS-500-7 (GGG50)
Disc: Cu Al10 Ni5 Fe4
Connection: Wafer Type PN10/16 - ASA 150
JIS 10K
Working pressure: 16 bar



ATEX sur demande / ATEX on request

				Manchette / Seat	
DN		L (mm)	Kg	EPDM CH / Heat EPDM	NBR
mm	inch			Ref.	Ref.
32/40	1"1/2	32,5	2,10	VPI4442-02EP0040	VPI4442-02NI0040
50	2"	42,5	2,70	VPI4442-02EP0050	VPI4442-02NI0050
65	2"1/2	45,5	3,10	VPI4442-02EP0065	VPI4442-02NI0065
80	3"	45,5	3,50	VPI4442-02EP0080	VPI4442-02NI0080
100	4"	51,5	4,40	VPI4442-02EP0100	VPI4442-02NI0100
125	5"	55,5	6,30	VPI4442-02EP0125	VPI4442-02NI0125
150	6"	55,5	7,75	VPI4442-02EP0150	VPI4442-02NI0150
200	8"	59,5	14,30	VPI4442-02EP0200	VPI4442-02NI0200
250	10"	67,5	20,55	VPI4442-02EP0250	VPI4442-02NI0250
300	12"	77,5	28,60	VPI4442-02EP0300	VPI4442-02NI0300

Température de service :
-15°C (-30°C pointe)
+130°C (+150°C pointe)

Working temperature:
-15°C (-30°C peak)
+130°C (+150°C peak)

Température de service :
-10°C (-20°C pointe)
+80°C (+90°C pointe)

Working temperature:
-10°C (-20°C peak)
+80°C (+90°C peak)

VPI4642-02

Poignée 3F | 3F Handle



Vanne à papillon oreilles taradées PN16 papillon bronze d'aluminium
Lug type butterfly valve PN16 aluminium bronze disc



Corps : Fonte ductile EN-GJS-500-7 (GGG50)
Papillon : Cu Al10 Ni5 Fe4
Raccordement : Entre brides oreilles
Taradées PN10 et PN16
Pression de service : 16 bar

Body: Ductile iron EN-GJS-500-7 (GGG50)
Disc: Cu Al10 Ni5 Fe4
Connection: Lug Type PN10 and PN16
Working pressure: 16 bar



ATEX sur demande / ATEX on request

				Manchette / Seat		
DN		PN	L (mm)	Kg	EPDM CH / Heat EPDM	NBR
mm	inch				Ref.	Ref.
40	1"1/2	16	32,5	2,50	VPI4642-02EP0040	VPI4642-02NI0040
50	2"	16	42,5	3,10	VPI4642-02EP0050	VPI4642-02NI0050
65	2"1/2	16	45,5	3,70	VPI4642-02EP0065	VPI4642-02NI0065
80	3"	16	45,5	4,90	VPI4642-02EP0080	VPI4642-02NI0080
100	4"	16	51,5	6,00	VPI4642-02EP0100	VPI4642-02NI0100
125	5"	16	55,5	9,40	VPI4642-02EP0125	VPI4642-02NI0125
150	6"	16	55,5	10,50	VPI4642-02EP0150	VPI4642-02NI0150
200	8"	10 16	59,5	20,70	VPI4642-02EP0200 VPI464216-02EP0200	VPI4642-02NI0200 VPI464216-02NI0200
250	10"	10 16	67,5	27,80	VPI4642-02EP0250 VPI464216-02EP0250	VPI4642-02NI0250 VPI464216-02NI0250
300	12"	10 16	77,5	35,60	VPI4642-02EP0300 VPI464216-02EP0300	VPI4642-02NI0300 VPI464216-02NI0300

Température de service :
-15°C (-30°C pointe)
+130°C (+150°C pointe)

Working temperature:
-15°C (-30°C peak)
+130°C (+150°C peak)

Température de service :
-10°C (-20°C pointe)
+80°C (+90°C pointe)

Working temperature:
-10°C (-20°C peak)
+80°C (+90°C peak)

KIT TECFLY

ACCESSOIRES, OPTIONS ET MOTORISATIONS
ACCESSORIES, OPTIONS AND ACTUATORS



POIGNEE INOX | STAINLESS STEEL HANDLE

Poignée Inox seule pour VPI
Stainless steel handle for VPI



Poignée avec secteur cranté tout Inox 304



Stainless Steel 304 handle with notched quadrant multi position

DN	Ref.VPI	
	mm	inch
32/40-150	1"1/2-6"	VPIPOIGIN-040150
200	8"	VPIPOIGIN-200
250	10"	VPIPOIGIN-250
300	12"	VPIPOIGIN-300

CFC MECANIQUE XCKP 102 TELEMECANIQUE SCHNEIDER | TELEMECANIQUE SCHNEIDER XCKP 102 MECHANICAL LIMIT SWITCHES

Kit contact fin de course mécanique XCKP102 pour VPI à poignée
Mechanical limit switches kit XCKP102 for butterfly valve with lever



Composé de:
- Plaque support Inox 304
- 2 contacts XCKP102

Comprised of:
- Stainless steel support plate 304
- 2 contacts XCKP102



Plaque support à la commande, prévoir délais / Delay for support plate

DN	Ref VPI		Ref VP PN25
	mm	inch	
32/40-100	1"1/2-4"	300180076	300180077
125-150	5"-6"	300180077	
200-300	8"-12"	300180078	300180078

CFC INDUCTIF | INDUCTIVE DETECTOR

Kit contact fin de course inductif pour VPI à poignée
Inductive sensor kit for butterfly valve with lever



Composé de :
- Plaque support Inox 304
- Détecteur inductif connecteur M12
- Connecteur pré-cablé coudé femelle M12 Lg 2M

Comprised of:
- Stainless steel support plate 304
- Inductive detector M12
- Angle Female M12 connection pre-wired connector length 2m



2 Contacts (ouvert et fermé) 2 Contacts (open/closed)		
DN	Ref. VPI	
	mm	inch
32/40-100	1"1/2-4"	300140021
125-150	5"-6"	300140022
200-300	8"-12"	300160075

BOITIER FIN DE COURSE / LIMIT SWITCH BOX

Kit boîtier fin de course sur équerre pour VPI à poignée
Limit switch box kit for butterfly valve with lever



Composé de :
- Plaque support Inox 304
- Boîtier fin de course IP68 pour vérin (modèle BTEFDC3)
- Entraîneur

Comprised of:
- Stainless steel support plate 304
- Limit switch IP68 (model BTEFDC3)
- Parts for limit switch box



DN	Ref. VPI	
	mm	inch
32/40-100	1"1/2-4"	300140012
125-150	5"-6"	300140013
200-300	8"-12"	300140014

Boîtiers fin de course seuls pages 57-58
Complete range of limit switches box pages 57-58

REDUCTEUR -08 | -08 GEARBOX

Réducteur mécanique pour vanne papillon Tecofi VPI
Gearbox for VPI Tecofi butterfly valve



Corps : Aluminium
Indicateur visuel de position

Body: Aluminium
Visual indicator position



Livré avec vis, rondelle (A2)
Supplied with bolt, washer (A2)



Les volants peuvent être livrés démontés pour l'optimisation de l'envoi. Nous vous invitons à spécifier le montage du volant lors de votre commande si impératif (coût de montage en sus).
Handwheels are delivered disassembled for the optimization of the shipment. Please contact us if it is imperative that the valve is shipped with handwheel assembled.

DN	Kg		Ref. VPI
	mm	inch	
32/40-100	1"1/2-4"	3,23	300180030
125-150	5"-6"	3,23	300180031
200-300	8"-12"	3,90	300180032



EN OPTION | OPTION

Kit cadenassable pour réducteur Tecofi
Padlock kit for Tecofi gearbox

Système de blocage du réducteur par cadenas composé de :
- Plaque de verrouillage
- Bague de verrouillage
- Cadenas

Padlock blocking system for gearbox, comprised of:
- Locking plate
- Locking ring
- Padlock

DN	Ref. VPI	
	mm	inch
32/40-150	1"1/2-6"	300200107
200-300	8"-12"	300200108



VPI

CFC MECANIQUE XCKM115 TELEMECANIQUE SCHNEIDER | TELEMECANIQUE SCHNEIDER MECHANICAL LIMIT SWITCH XCKM 115

Kit contact fin de course mécanique XCKM115 pour VPI à réducteur

Mechanical limit switches kit XCKM115 for butterfly valve gearbox



Composé de :
- Plaque support Inox 304
- 2 contacts XCKM115

Comprised of:
- Stainless steel support plate 304
- 2 contacts XCKM115

DN		Ref.VPI
mm	inch	
32/40 - 150	1"1/2-6"	300180351
200 - 300	8"-12"	300180352



Plaque support à la commande, prévoir délais / Delay for support plate

BOITIER FIN DE COURSE | LIMIT SWITCH BOX

Kit boîtier fin de course pour VPI à réducteur

Limit switch kit for VPI butterfly valve gearbox



Composé de :
- Support VPNREDUCT Inox 304
- Boîtier fin de course IP68 (modèle BTEFDC3)
- Entraîneur

Comprised of:
- Support VPNREDUCT Stainless steel 304
- Limit switch box IP68 (model BTEFDC3)
- Coupling

DN		Ref. VPI
mm	inch	
32/40-150	1"1/2-6"	300190253
200-300	8"-12"	300190254



Boîtiers fin de course seuls pages 57-58
Complete range of limit switches box on pages 57-58

KIT VOLANT A CHAINE | CHAINWHEEL KIT

Volant à chaîne pour vanne à papillon VPI

Chainwheel for VPI butterfly valve



Prix à ajouter à la VPI à poignée / Montage sur VPNREDUCT
Price to add to the manual VPI / Mounting on VPNREDUCT

Composé de :
- Réducteur TECOFI (VPNREDUCT)
- Rallonge inox 304
- Volant fonte ductile
- Guide chaîne Inox 304

Comprised of:
- TECOFI Gearbox (VPNREDUCT)
- Stainless steel 304 extension
- Ductile iron handwheel
- Stainless steel 304 chain guide

DN		Ref.VPI
mm	inch	
32/40-100	1"1/2-4"	300190225
125-150	5"-6"	300190226
200-300	8"-12"	300190227

	Ref
Chaîne acier zingué Zinc steel chain	VGCHAINE-AC01
Chaîne Inox 316L Stainless steel 316L chain	VGCHAINE-IN01



Prix au mètre à rajouter au KIT
Price per meter to add to the KIT

VPI MANCHETTE | SLEEVE FOR VPI

Manchette pour vanne à papillon VPI

Sleeve for VPI butterfly valve



Interchangeabilité des manchettes sur VPI
.EP / NI

Interchangeable sleeve for the VPI
.EP / NI

DN		EPDM CH - T° max : 130°C	NBR - T° max : 80°C
mm	inch	Ref.	Ref.
40	1"1/2	VPIMANCHS1-EP0040	VPIMANCHS1-NI0040
50	2"	VPIMANCHS1-EP0050	VPIMANCHS1-NI0050
65	2"1/2	VPIMANCHS1-EP0065	VPIMANCHS1-NI0065
80	3"	VPIMANCHS1-EP0080	VPIMANCHS1-NI0080
100	4"	VPIMANCHS1-EP0100	VPIMANCHS1-NI0100
125	5"	VPIMANCHS1-EP0125	VPIMANCHS1-NI0125
150	6"	VPIMANCHS1-EP0150	VPIMANCHS1-NI0150
200	8"	VPIMANCHS1-EP0200	VPIMANCHS1-NI0200
250	10"	VPIMANCHS1-EP0250	VPIMANCHS1-NI0250
300	12"	VPIMANCHS1-EP0300	VPIMANCHS1-NI0300



Manchette facilement remplaçable sur la VPI, (type à talon d'appui) permettant le montage avec tous types de brides. Dovetail-shaped seat, allowing installation with all types of flanges.

KIT COLONNETTE DROITE POUR VPI*

PEDESTAL FLOOR MOUNTING KIT FOR VPI BUTTERFLY VALVES*

À VOLANT | WITH HANDWHEEL



VOL1

GUICOL

Plaquette de guidage
Support plate

COL3-F10

Colonne
Pedestal

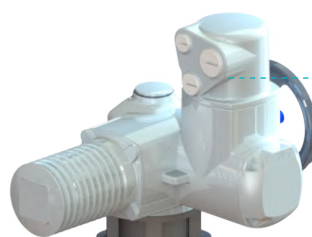

U04 AUMA

Actionneur
Actuator

F10AU1

Platine ISO
ISO Top Flange

COL3-F10

Colonne
Pedestal

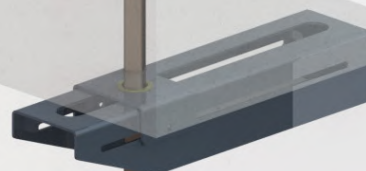

EXT1/2/3/4/5

Rallonge / Extension

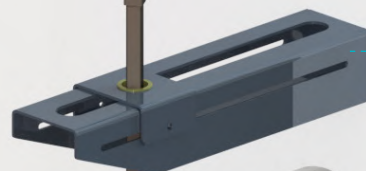

PAL2/3

Palier de guidage
Guide plate

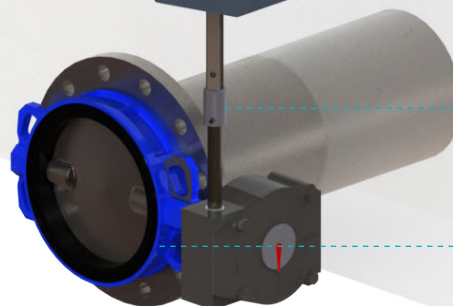

VPDOUILLE0140

VPDOUILLE0141

Entraîneur / Coupling adapter

VANNE PAPILLON VPI

VPI butterfly valve



Kit à utiliser avec les
vannes à papillon
VPI à réducteur, type :
VPI4X4X-08

Kit to use with gearbox
Tecfly butterfly valves
VPI type:
VPI4X4X-08

Représentation à titre indicatif (contre-bridés et tirants non représentés, ils sont obligatoires dans toutes installations).
Representation for reference only (counter flanges and tie rods not shown are required in all installations).

KIT COLONNETTE MURALE POUR VPI*

PEDESTAL WALL MOUNTING KIT FOR VPI BUTTERFLY VALVES*

À VOLANT | WITH HANDWHEEL

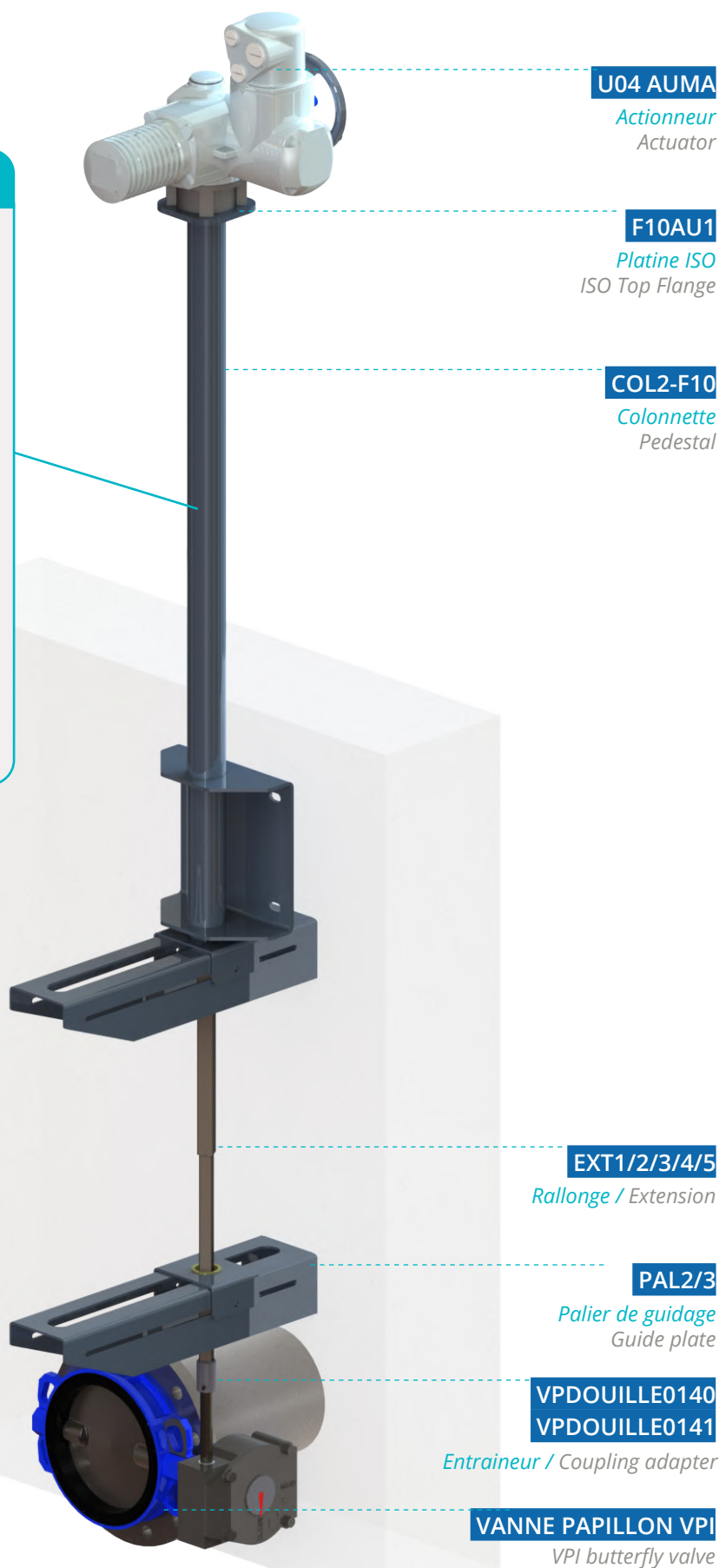

Kit à utiliser avec les vannes à papillon VPI à réducteur, type : **VPI4X4X-08**

Kit to use with gearbox Tecofi butterfly valves VPI type: **VPI4X4X-08**



La distance entre le mur et les colonnettes murales (COL1-COL2) n'est pas réglable, prévoir un déport avec le mur ou un système pour plaquer la colonnette à la bonne distance.

The distance between the wall and the wall column (COL1-COL2) is not adjustable, provide an offset with the wall or a system to place the column at the right distance.

Représentation à titre indicatif (contre-bridés et tirants non représentés, ils sont obligatoires dans toutes installations).
Representation for reference only (counter flanges and tie rods not shown are required in all installations).

**TRINGLERIES POUR MONTAGE SUR COLONNETTE - VPI**
LINKAGE FOR PEDESTAL MOUNTED - VPI

VPI

ENTRAINEUR | COUPLING ADAPTER

Entraîneur femelle pour tige de rallonge (EXT)

Female coupling adapter for extension (EXT)



Matière : Inox 304

Material: Stainless Steel 304

DN	Ref.
40-150	VPDOUILLE0140 (F05/F07)
200-300	VPDOUILLE0141 (F10)

A monter sur axe de sortie du réducteur
To mount on output shaft of a pressure reducing valve

RALLONGE | EXTENSION

Rallonge télescopique

Telescopic extension



Matière : Inox 316L

Material: Stainless Steel 316L

Dimension (mm)	Ref.
800-1100	EXT1
1100-1750	EXT2
1750-3000	EXT3
3000-5500	EXT4
4000-8000	EXT5

PALIER DE GUIDAGE | GUIDE PLATE

Palier de guidage fixe pour rallonge télescopique EXT

Guide plate bearing for telescopic extension EXT



Matière : Inox 316L

Material: Stainless Steel 316L

Dimension (mm)	Ref.
70-200	PAL2
70-500	PAL3



Mettre obligatoirement un palier tous les deux mètres + un autre avant le passage dans la colonnette.
Place one guide plate every two meters of the extension + one guide plate just before the pedestal floor.

COLONNETTE | PEDESTAL

Colonnette mécano-soudée pour vannes à papillon

Mechanically welded pedestal for butterfly valves

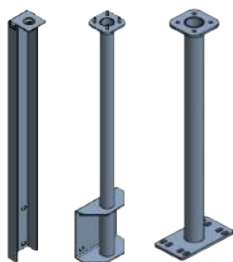

1

2

3



- COL1 : pour commande par volant et fixation murale
- COL2-F10 : pour commande motorisée et fixation murale
- COL3-F10 : pour fixation au sol

Matière : Inox 304
Hauteur fixe : 900mm

Pedestal wall mounted for handwheel
Pedestal wall mounted for Auma actuator
Pedestal floor mounted

Material: Stainless Steel 304
Fixed height: 900mm

Ref.
COL1
COL2-F10
COL3-F10

PLAQUE DE GUIDAGE | SUPPORT PLATE

Plaque de guidage pour colonnette fixation sol et commande par volant

Support plate for pedestal floor mounted handwheel



Matière : POM

Material: POM

Ref.
GUICOL



Permet de guider la rallonge
Used to guide the extension



A utiliser obligatoirement en cas de commande par volant sur colonnette COL3-F10.
To use only with handwheel operation on pedestal COL3-F10.



VOLANT | HANDWHEEL

Volant
HandwheelMatière : Acier revêtu Epoxy
Diamètre : 300mmMaterial: Epoxy-coated carbon steel
Diameter: 300mm

Ref.

VOL1

Adaptable sur extension
Adaptable with extension

PLATINE ISO POUR MOTEUR | ISO TOP FLANGE FOR ACTUATOR

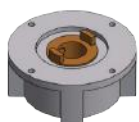
Platine pour moteur Auma
ISO top flange for Auma actuatorMatière : Fonte, écrou en bronze
Platine : ISO5210
Pour montage sur colonetteMaterial: Cast iron, bronze nut
Top mounting flange: ISO5210
For assembly on column

Ref.

F10AU1

Pour accouplement entre colonnette et moteur Auma
Coupling between the column and the Auma actuator

ACTIONNEUR U04 - MOTEUR VPI - COLONNETTE | AUMA ACTUATOR FOR VPI PEDESTAL MOUNTING

Motorisation Auma 3 phases 400V/50Hz On/Off
3-phase Auma actuator 400V/50Hz On/OffMoteur équipé de :
- 2 contacts fin de course
- 1 résistance de chauffe
- 2 limiteurs de couple
Commande manuelle de secours
Indicateur visuel de position
Protection IP68Actuator equipped with:
- 2 limit switches
- 1 heat resistor
- 2 torque limiters
Emergency handwheel
Visual position indicator
IP68 protection

DN	Ref.
32/40-300	SA07.2-U04B1TOR63



KIT TECFLY

MOTORISATIONS, ACCESSOIRES ET OPTIONS
ACTUATORS, ACCESSORIES AND OPTIONS



Voir guide technique pages 343 > 344
See technical guide on page 343 > 344

MOTEURS ÉLECTRIQUES | ELECTRIC ACTUATORS

Le type de moteur électrique doit être adapté aux conditions de service et aux bonnes préconisations.

Afin de bien choisir son moteur, il faut préciser :

- la pression de service et différentielle,
- l'environnement d'installation : température extérieure minimum et maximum, conditions d'installation, immersion permanente (milieu très humide, corrosif...)
- la nature du site : site industriel, site tertiaire, site nucléaire, site à risque (préciser le degré) ...
- les souhaits techniques de fonctionnement :
 - . couple de manoeuvre maximum requis - couple de régulation
 - . mouvement de la vanne : 1/4 tour - multi-tour - linéaire
 - . usinage de la noix (carré de 9, 11, 22, 27)
 - . éventuellement la dimension de la tige (pour vannes à tige montante)
 - . forme d'accouplement (forme A-B-C pour les multi-tour),
 - . usinage de douille (carré, méplat, alésage pour les 1/4 de tour)
- . tension d'alimentation
- . service moteur : tout ou rien, positionnement, régulation
- . temps de manoeuvre souhaité pour 1/4T - la vitesse de sortie pour multi-tour
- . bride de montage ISO de la vanne

Le débit dans la conduite peut augmenter le couple de manoeuvre.

The type of electric actuator must be adapted to working conditions and technical recommendations.

To choose the actuator type you need, you must specify the conditions:

- the maximum differential pressure,
- environmental conditions: minimum and maximum exterior temperatures, installation conditions (high humidity, corrosive environment, etc.)
- the type of site: industrial, nuclear, explosion risk etc.
- technical functioning conditions:
 - . maximum required operating torque - torque regulation
 - . direction or movement: quarter turn - multi-turn - linear
 - . nut machining (9, 11, 22, 27 square)
 - . stem dimensions (for valves with rising stems)
 - . connection form (A-B-C form for multi-turn)
 - . socket machining (square, flat, bored for 1/4 turn)
- . supply voltage
- . motor operation: on/off, positioning, regulation
- . operating time for 1/4 turn - output speed for multi-turn
- . valve ISO mounting plate

The flow rate in the pipe may raise the operating torque.



Tecofi'c
VALVE DESIGNER - FRANCE



auma
Solutions pour la vanne à rotation

Nos partenaires
Our partners



BERNARD
CONTROLS



STEP | Eau | BELGIQUE
WWTP | Water | BELGIUM



DESALINISATION | Eau | EMIRATS ARABES UNIS
Desalination | Water | UAE

ACTIONNEUR ÉLECTRIQUE 1/4T



VPI + VP PN25

TECOFI ELECTRIC ACTUATOR 1/4T

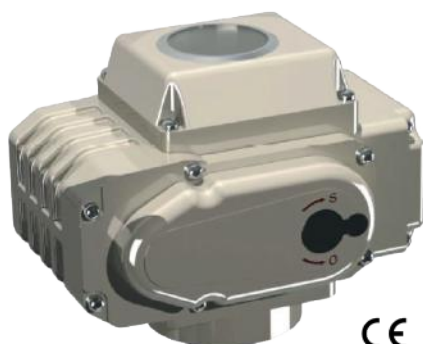

CE Tecofi
VALVE DESIGNER - FRANCE

CARACTÉRISTIQUES

- . Actionneur 1/4 de tour tout ou rien
- . Alimentation électrique 1PH 230V/50/60Hz ou 3PH 380V/50Hz/60Hz
- . Température de service : -30°C/+60°C

CHARACTERISTICS

- . Actuator for 1/4 turn valve
- . Power supply 1PH 230V/50/60Hz or 3PH 380V/50Hz/60Hz
- . Working temperature: -30°C/+60°C



AVANTAGES

- ✓ MEILLEUR RAPPORT QUALITE - PRIX
- ✓ LÉGER : boîtier aluminium
- ✓ COMPACT : faible encombrement
- ✓ COMPLET : indicateur de position, indice de protection IP67, 2 contacts fin de course SPDT ouverture/fermeture, butées mécaniques de fin de course réglables
- ✓ Commande manuelle de secours
- ✓ Résistance anti-condensation
- ✓ Protection thermique
- ✓ Indicateur visuel de position

ADVANTAGES

- ✓ BEST QUALITY-PRICE RATIO
- ✓ LIGHTWEIGHT : aluminum housing
- ✓ COMPACT
- ✓ FULLY EQUIPPED : position indicator, protection class IP67, 2 limit switches SPDT opening/closing, integrated heat resistance, mechanical stops
- ✓ Emergency manual control
- ✓ Condensation resistant
- ✓ Heat protection
- ✓ Visual position indicator



AGRÈMENTS ET NORMES

Fabrication répondant aux exigences de la directive européenne relative aux basses tensions : n° 2006/95/CE, la directive européenne machine n° 2006/42/CE, la directive européenne compatibilité électromagnétique n° 2004/108/CE.

AGREEMENTS AND STANDARDS

Manufactured according to the requirements of the European Directive «Low voltage» n° 2006/95/CE, the European Directive «Machinery» n° 2006/42/CE, and the European directive «Electromagnetic compatibility» n° 2004/108/CE.



Option boîtier de commande sur demande
Control box option on request

MOTEUR TECOFI N04 | N04 TECOFI ACTUATOR

Motorisation Tecofi TEA 3 phases 400V/50/60Hz On/Off

Tecofi electric actuator TEA 3-phase 400V/50/60Hz On/Off



Moteur équipé de :
- 2 contacts fin de course
- 1 résistance de chauffe
Commande manuelle de secours
Indicateur visuel de position
Protection IP67

Actuator equipped with:
- 2 limit switches
- 1 heat resistor
Emergency handwheel
Visual position indicator
IP67 protection

CE

Tecofi
VALVE DESIGNER - FRANCE

Triphasé | 3-phase

DN		VPI (ΔP 16 bar)		VP PN25 (ΔP 25 bar)	
		Type	Ref.	Type	Ref.
32/40	1"1/2			-	-
50	2"	TEA-05-N04	300180189	TEA-05-N04	300190293
65	2"1/2				
80	3"				
100	4"	TEA-10-N04	300180190	TEA-05-N04	300190294
125	5"			TEA-20-N04	300190295
150	6"	TEA-20-N04	300180191		
200	8"	TEA-40-N04	300180192	TEA-40-N04	300190296
250	10"			TEA-60-N04	300190297
300	12"	TEA-60-N04	300180193	TEA-100-N04	300200082



Gamme VP PN25 page 43
VP PN25 range on page 43



VPI + PN25

MOTEUR N24 | N24 ACTUATOR**Monophasé | 1-phase**Kit motorisation TEA 1 phase 230V/50/60Hz On/Off
Kit electric actuator TEA 1-phase 230V/50/60Hz On/Off

Moteur équipé de :

- 2 contacts fin de course
- 1 résistance de chauffe

Commande manuelle de secours
(avec clé hexagonale)
Indicateur visuel de position
Protection IP67

Actuator equipped with:

- 2 limit switches
- 1 heat resistor

Emergency handwheel
(with hexagon key)
Visual position indicator
IP67 protection

CE

Tecofi
VALVE DESIGNER - FRANCE

DN		VPI (ΔP 16 bar)		VP PN25 (ΔP 25 bar) NEW	
		Type	Ref.	Type	Ref.
32/40	1"1/4	TEA-05-N24	300180194	-	-
	1"1/2				
50	2"	TEA-05-N24	300180194	TEA-05-N24	300190299
65	2"1/2				
80	3"	TEA-10-N24	300180195	TEA-10-N24	300190300
100	4"				
125	5"	TEA-20-N24	300180196	TEA-20-N24	300190301
150	6"				
200	8"	TEA-40-N24	300180197	TEA-40-N24	300190302
250	10"				
300	12"	TEA-60-N24	300180198	TEA-60-N24	300190303
		TEA-100-N24		TEA-100-N24	300200083

MOTEUR U04 | U04 ACTUATOR**Triphasé | 3-phase**Kit motorisation AUMA 3 phases 400V/50Hz On/Off
Electric actuator AUMA kit 3-phase 400V/50Hz On/Off

Moteur équipé de :

- 2 contacts fin de course

Commande manuelle de secours
Indicateur visuel de position
Protection IP67 (IP68 en option)
Embase ISO
Fonction tout ou rien

Actuator equipped with:

- 2 limit switches

Manual emergency operating handwheel
Visual position indicator
IP67 protection
(option IP68)
ISO mounting plate
Function on-off

Modèle EQ / Model EQ

CE

auma
Solutions for all world in motion

Pas de commande de secours, ni limiteur de couple sur modèle ED
No manual emergency control, nor torque limiter on ED model



ATEX sur demande / ATEX on request

DN		VPI (ΔP 16 bar)		VP PN25 (ΔP 25 bar) NEW	
		Type	Ref.	Type	Ref.
32/40	1"1/4	ED25	300180203	ED25	300200235
	1"1/2				
50	2"	ED50	300180205	ED40	300200236
65	2"1/2				
80	3"	EQ100	300180207	ED50	300200237
100	4"				
125	5"	EQ150	300180211	EQ100	300200238
150	6"				
200	8"	EQ300	300180213	EQ150	300200239
250	10"				
300	12"	EQ600	300180215	EQ300	300200240
				EQ600	300200241
				EQ600	300200242
				SQ12.2	300200243

MOTEUR U24 | U24 ACTUATOR**Monophasé | 1-phase**Kit motorisation AUMA 1 phase 230V/50Hz On/Off
Electric actuator AUMA kit 1-phase 230V/50Hz On/Off

Moteur équipé de :

- 2 contacts fin de course

Commande manuelle de secours
Indicateur visuel de position
Protection IP67 (IP68 en option)
Embase ISO
Fonction tout ou rien

Actuator equipped with:

- 2 limit switches

Manual emergency operating handwheel
Visual position indicator
IP67 protection (option IP68)
ISO mounting plate
Function on-off

auma
Solutions for all world in motion

Pas de commande de secours, ni limiteur de couple sur modèle ED
No manual emergency control, nor torque limiter on ED model



ATEX sur demande / ATEX on request

DN		VPI (ΔP 16 bar)	
		Type	Ref.
32/40	1"1/4	ED25	300180204
	1"1/2		
50	2"	ED50	300180206
65	2"1/2		
80	3"	EQ100	300180208
100	4"		
125	5"	EQ150	300180212
150	6"		
200	8"	EQ300	300180214
250	10"		
300	12"	EQ600	300180216

Motorisation monophasée pour modèle VP PN25 sur demande
1-phase motorization for model VP PN25 on request





VPI + PN25

MOTEUR B04 | B04 ACTUATOR

Triphasé | 3-phase

Kit motorisation Bernard Controls - modèle AQ 3 phases 400V/50Hz On/Off
Kit electric actuator Bernard Controls - AQ model 3-phases 400V/50Hz On/Off



- Moteur équipé de :
- 4 contacts fin de course
 - 1 résistance de chauffe
- Commande manuelle de secours par volant
Indicateur visuel de position
Protection IP68
Embase ISO
Fonction tout ou rien



- Actuator equipped with:
- 4 limit switches
 - 1 heat resistor
- Manual emergency operating handwheel
Visual position indicator
IP68 protection
ISO mounting flange
Function on-off

DN		VPI (ΔP 16 bar)		VP PN25 (ΔP 25 bar)	
mm	inch	Type	Ref.	Type	Ref.
32/40-80	1"1/4 3	AQ05	300190059	AQ5	300200050
100	4"	AQ10	300190060	AQ10	300200051
125	5"			AQ15	300200052
150	6"	AQ15	300190061	AQ25	300200053
200	8"	AQ25	300190062	AQ50	300200054
250	10"	AQ50	300190063		
300	12"	AQ80	300190219	AQ80	300200055



Limiteur de couple à partir du modèle AQ15
Torque limiter from the model AQ15 and above

MOTEUR B24 | B24 ACTUATOR

Monophasé | 1-phase

Kit motorisation Bernard Controls - modèle AQ 1 phase 230V/50Hz On/Off
Kit electric actuator Bernard Controls - AQ model 1-phase 230V/50Hz On/Off



- Moteur équipé de :
- 4 contacts fin de course
 - 1 résistance de chauffe
- Commande manuelle de secours par volant
Indicateur visuel de position
Protection : IP68
Embase ISO
Fonction tout ou rien



- Actuator equipped with:
- 4 limit switches
 - 1 heat resistor
- Manual emergency operating handwheel
Visual position indicator
IP68 protection
ISO mounting plate
Function on-off

DN		VPI (ΔP 16 bar)	
mm	inch	Type	Ref.
32/40-80	1"1/4 - 3"	AQ5	300190064
100	4"	AQ10	300190065
125	5"		
150	6"	AQ15	300190066
200	8"	AQ25	300190067
250	10"	AQ50	300190068
300	12"	AQ80	300190220



Limiteur de couple à partir du modèle AQ15
Torque limiter from the model AQ15 and above

Motorisation monophasée pour modèle VP PN25 sur demande
1-phase motorization for model VP PN25 on request

REDUCTEUR | MANUAL OVERRIDE DECLUTCHABLE GEAR

Réducteur débrayable | Declutchable gear

Réducteur débrayable et vérin pneumatique double effet pour VPI
Declutchable wormgear and double-acting pneumatic actuator for VPI



MOA30 à MOA310 : Fonte grise
MOA850 : Fonte GS
TDA : Aluminium

- Composé de :
- Actionneur pneumatique double effet
 - Réducteur manuel débrayable
 - Adaptateur carré
 - Vis, rondelle Inox A2

MOA30 up to MOA310: Cast Iron
MOA850: Ductile Iron
TDA: Aluminium

- Comprised of:
- Double-acting pneumatic actuator
 - Declutchable manual reduction gear
 - Square adapter
 - Stainless steel A2 bolts and nuts

DN		VPI	
mm	inch	Type	Ref.
32/40-80	1"1/4 1"1/2-3"	MOA30 + TDA63	300180220
100	4"	MOA30 + TDA83	300180221
125	5"	MOA30 + TDA83	300180223
150	6"	MOA30 + TDA92	300180225
200	8"	MOA70 + TDA125	300180226
250	10"	MOA70 + TDA140	300180227
300	12"	MOA70 + TDA160	300180228



Nous ne recommandons pas le montage de réducteur débrayable sur un vérin pneumatique simple effet (en position NO, possibilité en version position NF).
Les volants sont livrés démontés pour l'optimisation de l'envoi. Nous vous invitons à spécifier le montage du volant lors de votre commande si impératif (coût de montage en sus).

We do not recommend mounting the gearbox on a single-acting pneumatic actuator (NO position, NC version on request).

Handwheels are delivered disassembled for the optimization of the shipment. Please contact us if it is imperative that the valve is shipped with handwheel assembled.

ACTIONNEUR PNEUMATIQUE 1/4T

TECOFI PNEUMATIC ACTUATOR 1/4T



VPI + VP PN25

La motorisation pneumatique sert à manoeuvrer automatiquement des vannes grâce à de l'air comprimé. Le déplacement est obtenu en changeant la pression de l'air, ce qui crée ou arrête un mouvement.

Pneumatic motorization automatically actuates valves using compressed air. A change in air pressure creates the movement, either starting or stopping it.

Suivant votre application, vous devrez déterminer si vous avez besoin d'un vérin simple effet ou double effet. Ce qui différencie ces deux types de technologies est la façon dont le vérin parvient à revenir à sa position initiale. L'utilisation d'un ressort permet au vérin simple effet de revenir facilement à sa position. Le déplacement d'un vérin double effet dans un sens ou dans l'autre est quant à lui contrôlé par des pressions appliquées alternativement de chaque côté du piston.

Depending on the application, you can determine if you need a spring return or double-acting actuator. The difference between these two types of actuators is how they return to their initial position. The spring allows the spring return actuator to return easily to its initial position. While the movement of a double-acting actuator in either direction is controlled by pressure being applied to each side of the piston.

Voir option filtres lubrificateurs page 63 à monter à l'amont des actionneurs pour améliorer les mouvements du vérin et limiter la poussière et les impuretés dans l'air d'arrivée.

Strainer options on page 63 for mounting actuators upstream to improve cylinder movements and limit dust and impurities in the intake air.



Double effet | Double-acting

Actionneurs préconisés pour une pression DELTA P de 10 bar et 25 bar (pour air moteur 6 bar), si pression de service dans la conduite différente, contactez le service commercial pour un chiffrage optimisé. Possibilité d'optimiser le choix de l'actionneur selon vos conditions d'utilisation (pression de service dans la conduite).
Actuators recommended for a DELTA P pressure of 10 and 25 bar. If the working pressure in the pipe is less than this, contact the sales team for a more precise quote. Possibility to choose an actuator more fitting to your conditions of use.

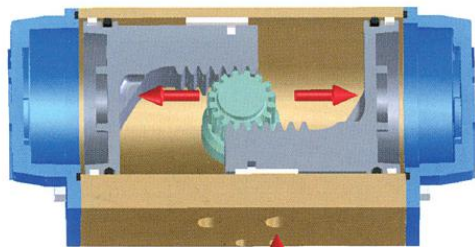

Position ouverte
Opened position

Vue de dessus
Top view

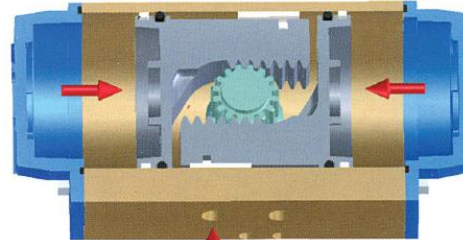

Position fermée
Closed position

KIT DOUBLE EFFET N03 | N03 DOUBLE-ACTING KIT

Kit motorisation pneumatique double effet
Double-acting pneumatic actuator kit



Construction: Aluminium
Pression de service :
6 bar (air lubrifié)
Butées réglables
Livré avec came de position

Construction: Aluminium
Working pressure:
6 bar (lubricated air)
Stop bolt retaining nut
Supplied with position cam



Tecofi
VALVE DESIGNER - FRANCE



ATEX ZONE 1/2/21/22

VPI (ΔP 16 bar)				VP PN25* (ΔP 25 bar) NEW			
DN		Type	Ref.	DN		Type	Ref.
mm	inch			mm	inch		
32/40-50	1"1/2-2"	TDA052	300160139	50/65	2-2"-2"1/2	TDA-063	300190284
65/80	2"1/2-3"	TDA063	300160140	80	2-3"	TDA-075	300190285
100	4"	TDA083	300160141	100	4"	TDA-083	300190286
125	5"	TDA083	300160142	125	5"	TDA-092	300190287
150	6"	TDA092	300160143	150	6"	TDA-105	300190288
200	8"	TDA125	300160144	200	8"	TDA-140	300190289
250	10"	TDA140	300160145	250	10"	TDA-160	300190290
300	12"	TDA160	300160146	300	12"	TDA-160	300190291



* Pour le PN25, nous préconisons l'installation d'un frein d'échappement sur l'électrodistIBUTEUR (ref EDFREIN p.62) afin d'allonger le temps de manoeuvre de la vanne (et augmenter la durée de vie du vérin). For PN25, we recommend installing an exhaust brake on solenoid valves (ref EDFREIN p.62) to lengthen the valve's operating time (and increase the lifespan of the actuator).



Simple effet | Single-acting



Pour le même couple, le vérin simple effet sera plus gros car le couple nécessaire pour manoeuvrer la vanne doit pouvoir comprimer les ressorts.

For the same torque, a spring return actuator will be larger because the required torque to operate the valve has to be able to compress the springs.



- ✓ Simple à installer
- ✓ Idéal pour les zones ATEX (air comprimé : limite le risque d'explosion)
- ✓ Rapidité du mouvement d'exécution
- ✓ Assure un contrôle fluide de la vitesse
- ✓ GRAND NOMBRE DE CYCLES DE MANŒUVRE ASSURÉ =

GARANTIE DE FONCTIONNEMENT !

(Soyez sûr de la bonne qualité de votre air comprimé).

- ✓ Easy to install
- ✓ Ideal for ATEX zones (compressed air: reduced risk of explosion)
- ✓ Speed of execution
- ✓ Good speed control
- ✓ A HIGH NUMBER OF OPERATING CYCLES =

GARANTEED OPERATION!

(Ensure the good quality of your compressed air).



VPI + VP PN25

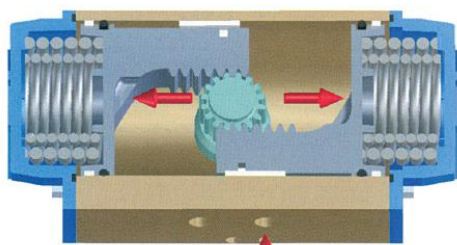

Position ouverte
Opened position

Vue de dessus
Top view

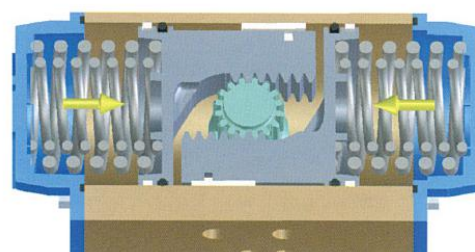

Position fermée
Closed position

KIT SIMPLE EFFET N07 | N07 SINGLE-ACTING KIT

Kit motorisation pneumatique simple effet
Single-acting pneumatic actuator kit



Construction: Aluminium
Pression de service :
6 bar (air lubrifié)
Butées réglables
Livré avec came de position

Construction: Aluminium
Working pressure:
6 bar (lubricated air)
Stop bolt retaining nut
Supplied with position cam



ATEX ZONE 1 / 2 / 21 / 22

VPI (ΔP 16 bar)				VP PN25* (ΔP 25 bar) NEW			
DN		Type	Ref.	DN		Type	Ref.
mm	inch			mm	inch		
32/40-50	1"1/2-2"	TSR063	300160147	32/40	1"1/4 / 1"1/2	TSR083	300190274
65	2"1/2	TSR083	300160148	50/65	2-2"-2"1/2	TSR083	300190275
80	3"	TSR092	300160149	80	3"	TSR105	300190276
100	4"	TSR105	300160150	100	4"	TSR125	300190277
125	5"	TSR125	300160151	125	5"	TSR140	300190278
150	6"	TSR140	300160152	150	6"	TSR160	300190279
200	8"	TSR160	300160153	200	8"	TSR190	300190280
250	10"	TSR190	300160154	250	10"	TSR210	300190281
300	12"	TSR210	300160155	300	12"	TSR270	300190282



* Pour le PN25, nous préconisons l'installation d'un frein d'échappement sur l'électrodistributeur (ref EDFREIN p.62) afin d'allonger le temps de manoeuvre de la vanne (et augmenter la durée de vie du vérin). For PN25, we recommend installing an exhaust brake on solenoid valves (ref EDFREIN p.62) to lengthen the valve's operating time (and increase the lifespan of the actuator).



Vérins simple effet / double effet avec butées réglables et came visuelle de position.
Single-acting / double-acting pneumatics actuators with adjustable limit stops and visual position cam.



Voir option KIT DETECTEUR INDUCTIF et autres ACCESSOIRES page 59.
See INDUCTIVE DETECTOR kit and other ACCESSORIES on page 59.

TECFLY VPG

DN 32/40-300 - PN16



SPÉCIAL GÉNIE CLIMATIQUE

MADE FOR HVAC

TECOFI lance la remplaçante de la VPE : la **VPG**.

Cette vanne conçue pour le marché du **génie climatique** offre le meilleur rapport qualité-prix du marché !

TECOFI launches the substitute for the VPE: the VPG. This valve is designed for the HVAC market and offers the best value for money!



Génie climatique/ HVAC



CORPS EN FONTE DUCTILE EN-GJS-400 -15 (GGG40)

Body material

Ductile iron EN-GJS-400-15 (GGG40)

PEINTURE EPOXY

Revêtement époxy poudre épaisseur mini 150µm

Epoxy coated

Powder epoxy coating with minimum 150µm thickness

CONSTRUCTION SIMPLE AXE

Type centerline, axe traversant,
acier inoxydable AISI 410

Single stem design

Centerline type, shaft in stainless steel AISI 410

MANCHETTE PERFORMANTE

Manchette EPDM CH pour une large plage de T°:
-15°C (-30°C pointe) / + 130°C (+ 150°C pointe)

Quality seat

HEAT EPDM seat ensures a large range of T° applications:
-15°C (-30°C peak) / + 130°C (+ 150°C peak)



POIGNEE MONOBLOC

Secteur acier revêtu époxy
Visserie de la poignée SS201
Poignée alu DN40-150
Poignée fonte GS DN200-300

Monobloc lever

Epoxy-coated steel quadrant
Stainless steel SS201 nuts
Aluminium handle DN40-150
Ductile iron handle DN200-300

GAMME COMPLETE

Raccordement entre brides
PN10/16 - ASA150 - JIS10K
DN32/40 au DN300
Oreilles lisses ou oreilles taraudées

Complete range

Between flanges
PN10/16 - ASA150 - JIS10K connection
DN32/40 to DN300
Wafer or lug model



Conforme aux exigences de tests de pression EN12266-1. Ecartement NF EN 558 série 20
Hydraulic test according to EN12266-1. Face to face according to NF EN 558 SERIE 20



Voir réducteur page 40
See gearbox on page 40



Fonte Ductile
Ductile Iron

VPG4448-02

Vanne à papillon entre brides PN16
Wafer type butterfly valve PN16

Poignée | Handle



**BIENTÔT DISPONIBLE
COMING SOON**



Corps : Fonte ductile EN-GJS-400-15 (GGG40)
Papillon : Fonte ductile EN-GJS-400-15 (GGG40)
revêtement nickelé
Raccordement : Entre brides PN10/16
ASA150Lbs - JIS10K
Pression de service max : 16 bar

Body: Ductile iron EN-GJS-400-15 (GGG40)
Disc: Ductile iron EN-GJS-400-15 (GGG40)
nickel plated
Connection: Between flanges PN10/16
ASA150Lbs - JIS10K
Maximum working pressure: 16 bar



ATEX sur demande / ATEX on request

CE

DN		L (mm)	Kg	Manchette / Seat	
mm	inch			EPDM CH Heat EPDM	NBR
				Ref.	Ref.
32/40	1"1/4 /1"1/2	33	1,6	VPG4448-02EP0040	VPG4448-02NI0040
50	2"	43	2,10	VPG4448-02EP0050	VPG4448-02NI0050
65	2"1/2	45	2,5	VPG4448-02EP0065	VPG4448-02NI0065
80	3"	45	3	VPG4448-02EP0080	VPG4448-02NI0080
100	4"	52	4,7	VPG4448-02EP0100	VPG4448-02NI0100
125	5"	56	6	VPG4448-02EP0125	VPG4448-02NI0125
150	6"	56	7,3	VPG4448-02EP0150	VPG4448-02NI0150
200	8"	60	12,9	VPG4448-02EP0200	VPG4448-02NI0200
250	10"	68	19	VPG4448-02EP0250	VPG4448-02NI0250
300	12"	78	30	VPG4448-02EP0300	VPG4448-02NI0300

Température de service :
-15°C (-30°C pointe)
+130°C (+150°C pointe)

Working temperature:
-15°C (-30°C peak)
+130°C (+150°C peak)

Température de service :
-10°C (-20°C pointe)
+80°C (+90°C pointe)

Working temperature:
-10°C (-20°C peak)
+80°C (+90°C peak)

VPG4648-02

Vanne à papillon oreilles taraudées PN16
Lug type butterfly valve PN16

Poignée | Handle



**BIENTÔT DISPONIBLE
COMING SOON**



Corps : Fonte ductile EN-GJS-400-15 (GGG40)
Papillon : Fonte ductile EN-GJS-400-15 (GGG40)
revêtement nickelé
Raccordement : Oreilles taraudées PN10 ou PN16
Pression de service max : 16 bar

Body: Ductile iron EN-GJS-400-15 (GGG40)
Disc: Ductile iron EN-GJS-400-15 (GGG40)
nickel plated
Connection: Lug type PN10 or PN16
Maximum working pressure: 16 bar



ATEX sur demande / ATEX on request

CE

DN		PN	L (mm)	Kg	Manchette / Seat	
mm	inch				EPDM CH Heat EPDM	NBR
					Ref.	Ref.
40	1"1/2	16	33	2,7	VPG4648-02EP0040	VPG4648-02NI0040
50	2"	16	43	3	VPG4648-02EP0050	VPG4648-02NI0050
65	2"1/2	16	45	3,5	VPG4648-02EP0065	VPG4648-02NI0065
80	3"	16	45	4,6	VPG4648-02EP0080	VPG4648-02NI0080
100	4"	16	52	6,6	VPG4648-02EP0100	VPG4648-02NI0100
125	5"	16	56	8,5	VPG4648-02EP0125	VPG4648-02NI0125
150	6"	16	56	10,4	VPG4648-02EP0150	VPG4648-02NI0150
200	8"	10 16	60	17,2	VPG4608-02EP0200 VPG4648-02EP0200	VPG4608-02NI0200 VPG4648-02NI0200
250	10"	10 16	68	28,2	VPG4608-02EP0250 VPG4648-02EP0250	VPG4608-02NI0250 VPG4648-02NI0250
300	12"	10 16	78	44	VPG4608-02EP0300 VPG4648-02EP0300	VPG4608-02NI0300 VPG4648-02NI0300

Température de service :
-15°C (-30°C pointe)
+130°C (+150°C pointe)

Working temperature:
-15°C (-30°C peak)
+130°C (+150°C peak)

Température de service :
-10°C (-20°C pointe)
+80°C (+90°C pointe)

Working temperature:
-10°C (-20°C peak)
+80°C (+90°C peak)



**Montage en bout de ligne possible avec
une contre-bride.** Veuillez à serrer les boulons
opposés en même temps et en croix.

**End-of-line mounting possible with
a flange.** Make sure to tighten crosswise the
opposite bolts at the same time.





VPG



VPG4449-02

Poignée | Handle



Vanne à papillon entre brides PN16
Wafer type butterfly valve PN16

**BIENTÔT DISPONIBLE
COMING SOON**



Corps : Fonte ductile EN-GJS-400-15 (GGG40)
Papillon : Acier Inoxydable A351 CF8M
Raccordement : Entre brides PN10/16
ASA150Lbs - JIS10K
Pression de service max : 16 bar

Body: Ductile iron EN-GJS-400-15 (GGG40)
Disc: Stainless steel A351 CF8M
Connection: Between flanges PN10/16
ASA150Lbs - JIS10K
Maximum working pressure: 16 bar



ATEX sur demande / ATEX on request

CE

					Manchette / Seat	
DN		L (mm)	Kg	EPDM CH	NBR	
mm	inch			Heat EPDM	Ref.	
32/40	1"1/4 /1"1/2	33	1,6	VPG4449-02EP0040	VPG4449-02NI0040	
50	2"	43	2,10	VPG4449-02EP0050	VPG4449-02NI0050	
65	2"1/2	45	2,5	VPG4449-02EP0065	VPG4449-02NI0065	
80	3"	45	3	VPG4449-02EP0080	VPG4449-02NI0080	
100	4"	52	4,7	VPG4449-02EP0100	VPG4449-02NI0100	
125	5"	56	6	VPG4449-02EP0125	VPG4449-02NI0125	
150	6"	56	7,3	VPG4449-02EP0150	VPG4449-02NI0150	
200	8"	60	12,9	VPG4449-02EP0200	VPG4449-02NI0200	
250	10"	68	19	VPG4449-02EP0250	VPG4449-02NI0250	
300	12"	78	30	VPG4449-02EP0300	VPG4449-02NI0300	

Température de service :
-15°C (-30°C pointe)
+130°C (+150°C pointe)
Working temperature:
-15°C (-30°C peak)
+130°C (+150°C peak)

Température de service :
-10°C (-20°C pointe)
+80°C (+90°C pointe)
Working temperature:
-10°C (-20°C peak)
+80°C (+90°C peak)

VPG4649-02

Poignée | Handle



Vanne à papillon oreilles taraudées PN16
Lug type butterfly valve PN16

**BIENTÔT DISPONIBLE
COMING SOON**



Corps : Fonte ductile EN-GJS-400-15 (GGG40)
Papillon : Acier Inoxydable A351 CF8M
Raccordement : Oreilles taraudées PN10 ou PN16
Pression de service max : 16 bar

Body: Ductile iron EN-GJS-400-15 (GGG40)
Disc: Stainless steel A351 CF8M
Connection: Lug type PN10 or PN16
Maximum working pressure: 16 bar



ATEX sur demande / ATEX on request

CE

					Manchette / Seat	
DN		PN	L (mm)	Kg	EPDM CH	NBR
mm	inch				Heat EPDM	Ref.
40	1"1/2	16	33	2,7	VPG4649-02EP0040	VPG4649-02NI0040
50	2"	16	43	3	VPG4649-02EP0050	VPG4649-02NI0050
65	2"1/2	16	45	3,5	VPG4649-02EP0065	VPG4649-02NI0065
80	3"	16	45	4,6	VPG4649-02EP0080	VPG4649-02NI0080
100	4"	16	52	6,6	VPG4649-02EP0100	VPG4649-02NI0100
125	5"	16	56	8,5	VPG4649-02EP0125	VPG4649-02NI0125
150	6"	16	56	10,4	VPG4649-02EP0150	VPG4649-02NI0150
200	8"	10 16	60	17,2	VPG4609-02EP0200 VPG4649-02EP0200	VPG4609-02NI0200 VPG4649-02NI0200
250	10"	10 16	68	28,2	VPG4609-02EP0250 VPG4649-02EP0250	VPG4609-02NI0250 VPG4649-02NI0250
300	12"	10 16	78	44	VPG4609-02EP0300 VPG4649-02EP0300	VPG4609-02NI0300 VPG4649-02NI0300

Température de service :
-15°C (-30°C pointe)
+130°C (+150°C pointe)
Working temperature:
-15°C (-30°C peak)
+130°C (+150°C peak)

Température de service :
-10°C (-20°C pointe)
+80°C (+90°C pointe)
Working temperature:
-10°C (-20°C peak)
+80°C (+90°C peak)

Montage en bout de ligne possible avec une contre-bride. Veuillez à serrer les boulons opposés en même temps et en croix.

End-of-line mounting possible with a flange. Make sure to tighten the opposite bolts at the same time and crosswise.

REDUCTEUR -08 | -08 GEARBOX

Réducteur | Gearbox

Réducteur mécanique pour vanne papillon Tecfly VPG
Gearbox for Tecfly VPG butterfly valve



Corps : Aluminium
Indicateur visuel de position

Body: Aluminium
Visual indicator position



**Livré avec vis, rondelle (A2)
Supplied with bolt, ring (A2)**



Les volants peuvent être livrés démontés pour l'optimisation de l'envoi. Nous vous invitons à spécifier le montage du volant lors de votre commande si impératif (coût de montage en sus).
Handwheels are delivered disassembled for the optimization of the shipment. Please contact us if it is imperative that the valve is shipped with handwheel assembled.

DN		Kg	Ref. VPI
mm	inch		
32/40-100	1"1/2-4"	3,23	300180030
125-150	5"-6"	3,23	300180031
200-300	8"-12"	3,90	300180032



**JUSQU'À ÉPUISEMENT DES STOCKS
WHILE STOCKS LAST**



VANNE À PAPILLON
BUTTERFLY VALVE

VPE3448-02 | VPE4448-02

Poignée 3F | Handle



Vanne à papillon entre brides PN16
Wafer type butterfly valve PN16



**JUSQU'À ÉPUISEMENT DES STOCKS
WHILE STOCKS LAST**

Corps :
DN 40-150 : Fonte EN-GJL-250 (GG25)
DN>150 : Fonte ductile EN-GJS-400-15 (GGG40)
Papillon : Fonte ductile EN-GJS-400-15 (GGG40)
Raccordement : Entre brides PN10/16
ASA150Lbs - JIS10K - GHOST
Pression de service max : 16 bar

Body:
DN 40-150 : Cast iron EN-GJL-250 (GG25)
DN>150 : Ductile iron EN-GJS-400-15 (GGG40)
Disc: Ductile iron EN-GJS-400-15 (GGG40)
Connection: Between flanges PN10/16
ASA150Lbs - JIS10K - GHOST
Maximum working pressure: 16 bar



DN		PN	L (mm)	Kg	Manchette / Seat	
mm	inch				EPDM CH Heat EPDM	NBR
					Ref.	Ref.
32/40	1 1/2	33	33	2,32	VPE3448-02EP0040	VPE3448-02NI0040
50	2"	43	43	2,90	VPE3448-02EP0050	VPE3448-02NI0050
65	2 1/2	46	46	3,46	VPE3448-02EP0065	VPE3448-02NI0065
80	3"	46	46	3,65	VPE3448-02EP0080	VPE3448-02NI0080
100	4"	52	52	4,56	VPE3448-02EP0100	VPE3448-02NI0100
125	5"	56	56	7,00	VPE3448-02EP0125	VPE3448-02NI0125
150	6"	56	56	8,60	VPE3448-02EP0150	VPE3448-02NI0150
200	8"	60	60	15,30	VPE4448-02EP0200	VPE4448-02NI0200
250	10"	68	68	22,10	VPE4448-02EP0250	VPE4448-02NI0250
300	12"	78	78	32,70	VPE4448-02EP0300	VPE4448-02NI0300

Température de service :
-15°C (-30°C pointe)
+130°C (+150°C pointe)
Working temperature:
-15°C (-30°C peak)
+130°C (+150°C peak)

Température de service :
-10°C (-20°C pointe)
+80°C (+90°C pointe)
Working temperature:
-10°C (-20°C peak)
+80°C (+90°C peak)

VPE3648-02 | VPE4648-02

Poignée 3F | Handle



Vanne à papillon oreilles taraudées PN16
Lug type butterfly valve PN16



**JUSQU'À ÉPUISEMENT DES STOCKS
WHILE STOCKS LAST**

Corps :
DN 40-150 : Fonte EN-GJL-250 (GG25)
DN>150 : Fonte ductile EN-GJS-400-15 (GGG40)
Papillon : Fonte ductile EN-GJS-400-15 (GGG40)
Raccordement : Entre brides oreilles taraudées
PN10 ou PN16
Pression de service max : 16 bar

Body:
DN 40-150 : Cast iron EN-GJL-250 (GG25)
DN>150 : Ductile iron EN-GJS-400-15 (GGG40)
Disc: Ductile iron EN-GJS-400-15 (GGG40)
Connection: Lug type PN10 or PN16
Maximum working pressure: 16 bar



DN		PN	L (mm)	Kg	Manchette / Seat	
mm	inch				EPDM CH Heat EPDM	NBR
					Ref.	Ref.
40	1 1/2	16	33	2,70	VPE3648-02EP0040	VPE3648-02NI0040
50	2"	16	43	3,50	VPE3648-02EP0050	VPE3648-02NI0050
65	2 1/2	16	46	4,26	VPE3648-02EP0065	VPE3648-02NI0065
80	3"	16	46	4,79	VPE3648-02EP0080	VPE3648-02NI0080
100	4"	16	52	6,3	VPE3648-02EP0100	VPE3648-02NI0100
125	5"	16	56	9,6	VPE3648-02EP0125	VPE3648-02NI0125
150	6"	16	56	10,58	VPE3648-02EP0150	VPE3648-02NI0150
200	8"	10 16	60	19	VPE4648-02EP0200 VPE464816-02EP0200	VPE4648-02NI0200 VPE464816-02NI0200
250	10"	10 16	68	28,40	VPE4648-02EP0250 VPE464816-02EP0250	VPE4648-02NI0250 VPE464816-02NI0250
300	12"	10 16	78	43,42	VPE4648-02EP0300 VPE464816-02EP0300	VPE4648-02NI0300 VPE464816-02NI0300

Température de service :
-15°C (-30°C pointe)
+130°C (+150°C pointe)
Working temperature:
-15°C (-30°C peak)
+130°C (+150°C peak)

Température de service :
-10°C (-20°C pointe)
+80°C (+90°C pointe)
Working temperature:
-10°C (-20°C peak)
+80°C (+90°C peak)



JUSQU'À ÉPUISEMENT DES STOCKS
WHILE STOCKS LAST



VPE3449-02 | VPE4449-02

Poignée 3F | Handle

Vanne à papillon entre brides PN16
Wafer type butterfly valve PN16



**JUSQU'À ÉPUISEMENT DES STOCKS
WHILE STOCKS LAST**

Corps :
DN 40-150 : Fonte EN-GJL-250 (GG25)
DN>150 : Fonte ductile EN-GJS-400-15 (GGG40)
Papillon : Inox 316
Raccordement : Entre brides PN10/16
ASA150Lbs - JIS10K
Pression de service max : 16 bar

Body:
DN 40-150 : Cast iron EN-GJL-250 (GG25)
DN>150 : Ductile iron EN-GJS-400-15 (GGG40)
Disc: Stainless steel 316
Connection: Between flanges PN10/16
ASA150Lbs - JIS10K
Maximum working pressure: 16 bar



ATEX sur demande / on request

DN		PN	L (mm)	Kg	Manchette / Seat	
mm	inch				EPDM CH Heat EPDM	NBR
					Ref.	Ref.
32/40	1 1/2"	33	33	2,30	VPE3449-02EP0040	VPE3449-02NI0040
50	2"	43	43	2,86	VPE3449-02EP0050	VPE3449-02NI0050
65	2 1/2"	46	46	3,40	VPE3449-02EP0065	VPE3449-02NI0065
80	3"	46	46	3,60	VPE3449-02EP0080	VPE3449-02NI0080
100	4"	52	52	4,50	VPE3449-02EP0100	VPE3449-02NI0100
125	5"	56	56	6,96	VPE3449-02EP0125	VPE3449-02NI0125
150	6"	56	56	8,50	VPE3449-02EP0150	VPE3449-02NI0150
200	8"	60	60	15,00	VPE4449-02EP0200	VPE4449-02NI0200
250	10"	68	68	21,80	VPE4449-02EP0250	VPE4449-02NI0250
300	12"	78	78	32,38	VPE4449-02EP0300	VPE4449-02NI0300

Température de service :
-15°C (-30°C pointe)
+130°C (+150°C pointe)

Working temperature:
-15°C (-30°C peak)
+130°C (+150°C peak)

Température de service :
-10°C (-20°C pointe)
+80°C (+90°C pointe)

Working temperature:
-10°C (-20°C peak)
+80°C (+90°C peak)



VPE3649-02 | VPE4649-02

Poignée 3F | Handle

Vanne à papillon oreilles taraudées PN16
Lug type butterfly valve PN16



**JUSQU'À ÉPUISEMENT DES STOCKS
WHILE STOCKS LAST**

Corps :
DN 40-150 : Fonte EN-GJL-250 (GG25)
DN>150 : Fonte ductile EN-GJS-400-15 (GGG40)
Papillon : Inox 316
Raccordement : Entre brides oreilles taraudées PN10 ou PN16
Pression de service max : 16 bar

Body:
DN 40-150 : Cast iron EN-GJL-250 (GG25)
DN>150 : Ductile iron EN-GJS-400-15 (GGG40)
Disc: Stainless steel 316
Connection: Lugs type PN10 or PN16
Maximum working pressure: 16 bar



ATEX sur demande / on request

DN		PN	L (mm)	Kg	Manchette / Seat	
mm	inch				EPDM CH Heat EPDM	NBR
					Ref.	Ref.
40	1 1/2"	16	33	2,64	VPE3649-02EP0040	VPE3649-02NI0040
50	2"	16	43	3,46	VPE3649-02EP0050	VPE3649-02NI0050
65	2 1/2"	16	46	4,20	VPE3649-02EP0065	VPE3649-02NI0065
80	3"	16	46	4,74	VPE3649-02EP0080	VPE3649-02NI0080
100	4"	16	52	6,24	VPE3649-02EP0100	VPE3649-02NI0100
125	5"	16	56	9,56	VPE3649-02EP0125	VPE3649-02NI0125
150	6"	16	56	10,48	VPE3649-02EP0150	VPE3649-02NI0150
200	8"	10	60	18,70	VPE4649-02EP0200 VPE464916-02EP0200	VPE4649-02NI0200 VPE464916-02NI0200
250	10"	10	68	28,10	VPE4649-02EP0250 VPE464916-02EP0250	VPE4649-02NI0250 VPE464916-02NI0250
300	12"	10	78	43,10	VPE4649-02EP0300 VPE464916-02EP0300	VPE4649-02NI0300 VPE464916-02NI0300

Température de service :
-15°C (-30°C pointe)
+130°C (+150°C pointe)

Working temperature:
-15°C (-30°C peak)
+130°C (+150°C peak)

Température de service :
-10°C (-20°C pointe)
+80°C (+90°C pointe)

Working temperature:
-10°C (-20°C peak)
+80°C (+90°C peak)



APPLICATIONS SPÉCIFIQUES
SPECIFIC APPLICATIONS

VP4458-02 | VP4458-08 | VP4458-N03 | VP4458-N07

PN25



Vanne à papillon entre brides PN25
Wafer type butterfly valve PN25

Idéal pour stations de pompage / réseau incendie
Ideal for pumping stations / fire network



Poignée -02 jusqu'au DN150
Handle -02 up to DN150



Corps : Fonte EN-GJS-400-15 (GGG40)
Papillon : Fonte EN-GJS-400-15 (GGG40) nickelé
Manchette : EPDM chaleur
Raccordement : Entre brides oreilles lisses PN25
Pression de service : 25 bar
Température de service :
-15°C/+130°C (-30°C/+150°C pointe)
Manoeuvre : DN50-150 : Levier
DN200-300 : Réducteur

Body: Ductile iron EN-GJS-400-15 (GGG40)
Disc: Ductile iron EN-GJS-400-15 (GGG40) nickel-plated
Seat: Heat EPDM
Connection: Wafer type PN25
Working pressure: 25 bar
Working temperature:
-15°C/+130°C (-30°C/+150°C peak)
Operator: DN50-150: Lever
DN200-300: Gearbox

DN		L (mm)	Kg	Poignée / Handle	
mm	inch			Ref.	
50	2"	43	3,50	VP4458-02EP0050	
65	2 1/2"	46	4,40	VP4458-02EP0065	
80	3"	46	5,20	VP4458-02EP0080	
100	4"	52	6,80	VP4458-02EP0100	
125	5"	56	8,80	VP4458-02EP0125	
150	6"	56	10,80	VP4458-02EP0150	

DN		L (mm)	Kg	Réducteur* / Gearbox	
mm	inch			Ref.	
200	8"	60	23,20	VP4458-08EP0200	
250	10"	68	30,00	VP4458-08EP0250	
300	12"	78	49,30	VP4458-08EP0300	

! *Les volants peuvent être livrés démontés pour l'optimisation de l'envoi. Nous vous invitons à spécifier le montage du volant lors de votre commande si impératif (coût de montage en sus).
The steering wheels can be delivered disassembled for the optimization of the shipment. Please contact us if it is imperative that the valve is shipped with handwheel assembled.



Réducteur -08 à partir du DN200
Gearbox -08 from DN200



Vérin N03 / N07
Actuator

DN		L (mm)	Kg	Vérin / Actuator	
mm	inch			Ref.	
				Double effet / Double-acting	Simple effet / Single-acting
				Ref.	
50	2"	43	5,53	VP4458-N03EP0050	VP4458-N07EP0050
65	2 1/2"	46	7,53	VP4458-N03EP0065	VP4458-N07EP0065
80	3"	46	9,80	VP4458-N03EP0080	VP4458-N07EP0080
100	4"	52	13,57	VP4458-N03EP0100	VP4458-N07EP0100
125	5"	56	17,70	VP4458-N03EP0125	VP4458-N07EP0125
150	6"	56	24,05	VP4458-N03EP0150	VP4458-N07EP0150
200	8"	60	43,34	VP4458-N03EP0200	VP4458-N07EP0200
250	10"	68	61,30	VP4458-N03EP0250	VP4458-N07EP0250
300	12"	78	96,10	VP4458-N03EP0300	VP4458-N07EP0300

NEW

Kit motorisation pour VP PN25 pages 33>35
Actuator kit for VP PN25 on pages 33>35

NEW

Vérin pneumatique seul pour VP PN25 pages 36-37
Pneumatic actuator on pages 36-37

VP5445S-02 | VP5445S-08

Acier | Steel



Vanne à papillon entre brides acier PN10/16/ASA150
Wafer steel butterfly valve PN10/16/ASA150



Modèle réducteur manuel à volant -08
Manual gearbox model with handwheel -08



Corps : Acier A216 WCB
Papillon : Acier A216 WCB revêtu époxy
Manchette : EPDM chaleur
Raccordement : Entre brides PN10/16 ASA150Lbs
Pression de service : 16 bar
Température de service : -15°C / +130°C (-30°C / +150°C pointe)
Manoeuvre : DN50-150 : Levier
DN200-300 : Réducteur

Body: Carbon steel A216 WCB
Disc: Steel A216 WCB epoxy coated
Seat: Heat EPDM
Connection: Wafer type PN10/16 ASA150Lbs
Working pressure: 16 bar
Working temperature: -15°C / +130°C (-30°C / +150°C peak)
Operator: DN50-150 : Lever
DN200-300 : Gearbox

DN		L (mm)	Kg	Poignée / Handle	
mm	inch			Ref.	
50	2"	42	2,15	VP5445S-02EP0050	
65	2 1/2"	44,7	2,70	VP5445S-02EP0065	
80	3"	45,2	3,10	VP5445S-02EP0080	
100	4"	52	5,10	VP5445S-02EP0100	
125	5"	54,4	6,45	VP5445S-02EP0125	
150	6"	55,8	8,15	VP5445S-02EP0150	

DN		L (mm)	Kg	Réducteur* / Gearbox*	
mm	inch			Ref.	
200	8"	60,6	21,00	VP5445S-08EP0200	
250	10"	65,6	27,00	VP5445S-08EP0250	
300	12"	76,9	37,00	VP5445S-08EP0300	



Corps acier idéal pour réseaux incendie.
Carbon steel body ideal for fire prevention and extinction networks.



Nous consulter pour motorisation / Please consult us for actuator assembly
*Les volants peuvent être livrés démontés pour l'optimisation de l'envoi. Nous vous invitons à spécifier le montage du volant lors de votre commande si impératif (coût de montage en sus).
The steering wheels can be delivered disassembled for the optimization of the shipment. Please contact us if it is imperative that the valve is shipped with handwheel assembled.



VANNE DOUBLE BRIDE EN U DOUBLE "U" FLANGED VALVE



Nouvelle gamme: raccordement double bride corps en U série 20 New range with double U-flanged connection, series 20

- ✓ La tolérance définie par les 2 brides permet un positionnement correct et rapide.
 - ✓ Montage facile et manipulations de maintenance optimisées.
 - ✓ Construction simple et compacte, opération marche-arrêt rapide.
 - ✓ Faible couple de manœuvre, économie d'énergie.
 - ✓ Construction 100% étanche.
 - ✓ Axe de manœuvre acier Inoxydable 410.
 - ✓ Longue durée de vie, fiabilité.
- ✓ The tolerance defined by the 2 flanges allows correct and fast positioning.
 - ✓ Easy assembly and optimized maintenance operations.
 - ✓ Simple and compact construction, quick 90° on-off operation.
 - ✓ Minimized operating torque, energy saving.
 - ✓ 100% Watertight design.
 - ✓ Shaft in Stainless steel 410.
 - ✓ Long service life.



Version ACS, sur demande / ACS version on request



Fonte ductile | Ductile Iron

VP4548A | VP4508A

Vanne à papillon double bride PN10/16

Ductile iron double flanged butterfly valve PN10/16



Corps et papillon : Fonte ductile EN-GJS-400-15 (GGG40) / papillon nickelé
Manchette : EPDM chaleur
Raccordement : Double bride PN10 ou PN16
Pression de service max : 16 bar
Température de service :
 -15°C/+130°C (-30°C/+150°C pointe)

Body and Disc: Ductile iron EN-GJS-400-15 GGG40 / nickel-plated disc

Sleeve: Heat EPDM

Connection: Flanged U type PN10 or PN16

Max working pressure: 16 bar

Working temperature:
 -15°C/+130°C (-30°C/+150°C peak)

DN		L (mm)	Kg	PN	Poignée / Handle	Réducteur / Gearbox
mm	inch				Ref.	Ref.
50	2"	43	5,3	16	VP4548A-02EP0050	VP4548A-08EP0050
65	2 1/2"	46	5,9	16	VP4548A-02EP0065	VP4548A-08EP0065
80	3"	46	6,6	16	VP4548A-02EP0080	VP4548A-08EP0080
100	4"	52	9,5	16	VP4548A-02EP0100	VP4548A-08EP0100
125	5"	56	10,8	16	VP4548A-02EP0125	VP4548A-08EP0125
150	6"	56	13,4	16	VP4548A-02EP0150	VP4548A-08EP0150
200	8"	60	26,2	10	VP4508A-02EP0200	VP4508A-08EP0200
				16	VP4548A-02EP0200	VP4548A-08EP0200
250	10"	68	31,9	10	VP4508A-02EP0250	VP4508A-08EP0250
				16	VP4548A-02EP0250	VP4548A-08EP0250
300	12"	78	51,5	10	VP4508A-02EP0300	VP4508A-08EP0300
				16	VP4548A-02EP0300	VP4548A-08EP0300



Nous consulter pour motorisation / Please consult us for actuator assembly



Fonte ductile | Ductile Iron

VP4538-02 | VP4538-08

Vanne à papillon double bride - ASA 150

Ductile iron double flanged butterfly valve - ASA 150



Corps et papillon : Fonte ductile EN-GJS-400-15 (GGG40) / papillon nickelé
Manchette : EPDM chaleur
Raccordement : Double bride ASA 150
Pression de service max : 16 bar
Température de service :
 -15°C/+130°C (-30°C/+150°C pointe)

Body and Disc: Ductile iron EN-GJS-400-15 GGG40 / nickel-plated disc

Sleeve: Heat EPDM

Connection: Flanged U type ASA 150

Max working pressure: 16 bar

Working temperature:
 -15°C/+130°C (-30°C/+150°C peak)

DN		L (mm)	Kg	Poignée / Handle	Réducteur / Gearbox
mm	inch			Ref.	Ref.
50	2"	43	5,4	VP4538-02EP0050	VP4538-08EP0050
65	2 1/2"	46	5,7	VP4538-02EP0065	VP4538-08EP0065
80	3"	46	6,9	VP4538-02EP0080	VP4538-08EP0080
100	4"	52	9,8	VP4538-02EP0100	VP4538-08EP0100
125	5"	56	11,1	VP4538-02EP0125	VP4538-08EP0125
150	6"	56	13,7	VP4538-02EP0150	VP4538-08EP0150
200	8"	60	19,7	VP4538-02EP0200	VP4538-08EP0200
250	10"	68	31,9	VP4538-02EP0250	VP4538-08EP0250
300	12"	78	51,5	VP4538-02EP0300	VP4538-08EP0300



Nous consulter pour motorisation / Please consult us for actuator assembly





Acier Inox | Stainless Steel

VP4549A | VP4509A

Vanne à papillon double bride PN10/16

Ductile iron double flanged butterfly valve PN10/16



Corps : Fonte ductile EN-GJS-400-15 (GGG40)
Papillon : Acier inoxydable CF8M
Manchette : EPDM chaleur
Raccordement : Double bride PN10 ou PN16
Pression de service max : 16 bar
Température de service :
-15°C/+130°C (-30°C/+150°C pointe)

Body: Ductile iron EN-GJS-400-15 (GGG40)
Disc: Stainless steel CF8M
Sleeve: Heat EPDM
Connection: Flanged U type PN10 or PN16
Max working pressure: 16 bar
Working temperature:
-15°C/+130°C (-30°C/+150°C peak)

DN		L (mm)	Kg	PN	Poignée / Handle	Réducteur / Gearbox
mm	inch				Ref.	Ref.
50	2"	43	5,3	16	VP4549A-02EP0050	VP4549A-08EP0050
65	2"1/2	46	5,9	16	VP4549A-02EP0065	VP4549A-08EP0065
80	3"	46	6,6	16	VP4549A-02EP0080	VP4549A-08EP0080
100	4"	52	9,5	16	VP4549A-02EP0100	VP4549A-08EP0100
125	5"	56	10,8	16	VP4549A-02EP0125	VP4549A-08EP0125
150	6"	56	13,4	16	VP4549A-02EP0150	VP4549A-08EP0150
200	8"	60	26,2	10	VP4509A-02EP0200	VP4509A-08EP0200
				16	VP4549A-02EP0200	VP4549A-08EP0200
250	10"	68	31,9	10	VP4509A-02EP0250	VP4509A-08EP0250
				16	VP4549A-02EP0250	VP4549A-08EP0250
300	12"	78	51,5	10	VP4509A-02EP0300	VP4509A-08EP0300
				16	VP4549A-02EP0300	VP4549A-08EP0300



Nous consulter pour motorisation / Please consult us for actuator assembly



Acier Inox | Stainless Steel

VP4539-02 | VP4539-08

Vanne à papillon double bride - ASA150

Ductile iron double flanged butterfly valve ASA150



Corps : Fonte ductile EN-GJS-400-15 (GGG40)
Papillon : Acier inoxydable CF8M
Manchette : EPDM chaleur
Raccordement : Double bride ASA150
Pression de service max : 16 bar
Température de service :
-15°C/+130°C (-30°C/+150°C pointe)

Body: Ductile iron EN-GJS-400-15 (GGG40)
Disc: Stainless steel CF8M
Sleeve: Heat EPDM
Connection: Flanged U type ASA 150
Max working pressure: 16 bar
Working temperature:
-15°C/+130°C (-30°C/+150°C peak)

DN		L (mm)	Kg	Poignée / Handle	Réducteur / Gearbox
mm	inch			Ref.	Ref.
50	2"	43	5,4	VP4539-02EP0050	VP4539-08EP0050
65	2"1/2	46	5,7	VP4539-02EP0065	VP4539-08EP0065
80	3"	46	6,9	VP4539-02EP0080	VP4539-08EP0080
100	4"	52	9,8	VP4539-02EP0100	VP4539-08EP0100
125	5"	56	11,1	VP4539-02EP0125	VP4539-08EP0125
150	6"	56	13,7	VP4539-02EP0150	VP4539-08EP0150
200	8"	60	19,7	VP4539-02EP0200	VP4539-08EP0200
250	10"	68	31,9	VP4539-02EP0250	VP4539-08EP0250
300	12"	78	51,5	VP4539-02EP0300	VP4539-08EP0300



Nous consulter pour motorisation / Actuator assembly on request

TECLARGE

VANNE PAPILLON | BUTTERFLY VALVE DN 350-1200 - PN10/16/ASA150



Usage général : eau, rejets, hydrocarbures...
General use: water, discharges, hydrocarbons...

RÉDUCTEUR MOTORISABLE AVEC INDICATEUR D'OUVERTURE

Actuated gearbox operator with position indicator

PLATINE DE MOTORISATION

ISO Top flange for actuator

CORPS FONTE DUCTILE EN-GJS-400-15 REVÊTEMENT ÉPOXY 250 MICRONS

Ductile iron body EN-GJS-400-15 epoxy coated 250µm

BUTÉES RÉGLABLES

Adjustable stops

RACCORDEMENT WAFER PN10 SELON LA NORME EN 1092-2

(PN16/ASA150 sur demande)
Wafer connection PN10 according to EN1092-2 (PN16/ASA150 on request)



CE



WAFER AVEC BRIDE CENTRALE MUNIE DE TROUS LISSES DU DN700 AU DN1200

Wafer type with middle flange having smooth holes from DN700 to DN1200

WAFER AVEC OREILLES DE CENTRAGE DU DN350 AU DN600

Wafer type with smooth ears from DN350 to DN600

EN OPTION | OPTION

CARRÉ DE FONTAINIER | CONICAL SQUARE

Adaptateur carré conique pour axe
Conical square coupling for stem



Se positionne en sortie de réducteur pour une manœuvre par clé de fontainier (page 143)
Livré avec une vis de "pression" / blocage.
Can be positioned at the output of the gearbox for operation by fountain key (page 143)
Delivered with thrust screw



Permet les montages à rallonge
Used for extension model

DN	PN	Ref.
350-1000	10	CARRE-B3F10
1200	10	CARRE-B3F14
350-700	16	CARRE-B3F10
800-1200		CARRE-B3F14

TECLARGE

OREILLES LISSES - SÉRIE 20 WAFER TYPE - SERIES 20

PN10

VPE4408-08EP | VPE4408-08EPA | VPE4409-08EP | VPE4409-08EPA

Vanne à papillon entre brides PN10
Wafer type butterfly valve PN10



Corps : Fonte Ductile EN-GJS-400-15 (GGG40)
Papillon : Fonte Ductile EN-GJS-400-15 (GGG40) nickelé ou Inox 316
Manchette : EPDM chaleur ou EPDM ACS
Raccordement : Entre brides PN10
Pression de service : 10 bar
Température de service : +130°C (+150°C pointe) / -15°C (-30°C pointe)
Température de service ACS : +110°C (+130°C pointe) / +4°C (-20°C pointe)
Manœuvre : Réducteur à volant avec platine de motorisation ISO

Body: Ductile iron EN-GJS-400-15 (GGG40)
Disc: Ductile iron EN-GJS-400-15 (GGG40) nickel-plated or Stainless steel 316
Sleeve: Heat EPDM
Connection: Wafer type PN10
Working pressure: 10 bar
Working temperature: +130°C (+150°C peak) / -15°C (-30°C peak)
Working temperature for ACS: +110°C (+130°C peak) / +4°C (-20°C peak)
Operation: Gearbox with handwheel and ISO top flange for electric actuator connection



Version ACS pour Eau Potable
ACS certification for Drinking Water



* sans bride centrale du DN350 au DN600 / Without central flange from DN350 to DN600

CE

				Papillon / Disc				
				Fonte ductile / Ductile Iron		Inox 316 / Stainless steel 316		
DN	mm	inch	L (mm)	Kg	Manchette / Seat EPDM CH	Manchette / Seat EPDM	Manchette / Seat EPDM CH	Manchette / Seat EPDM
						ACS		ACS
350 *	14"	76,5	68	VPE4408-08EP0350	VPE4408-08EPA0350	VPE4409-08EP0350	VPE4409-08EPA0350	
400 *	16"	102	89	VPE4408-08EP0400	VPE4408-08EPA0400	VPE4409-08EP0400	VPE4409-08EPA0400	
450 *	18"	114	104	VPE4408-08EP0450	VPE4408-08EPA0450	VPE4409-08EP0450	VPE4409-08EPA0450	
500 *	20"	130	126	VPE4408-08EP0500	VPE4408-08EPA0500	VPE4409-08EP0500	VPE4409-08EPA0500	
600 *	24"	151	222	VPE4408-08EP0600	VPE4408-08EPA0600	VPE4409-08EP0600	VPE4409-08EPA0600	
700	28"	163	336	VPE4408-08EP0700	VPE4408-08EPA0700	VPE4409-08EP0700	VPE4409-08EPA0700	
800	32"	188	431	VPE4408-08EP0800	VPE4408-08EPA0800	VPE4409-08EP0800	VPE4409-08EPA0800	
900	36"	203	548	VPE4408-08EP0900	VPE4408-08EPA0900	VPE4409-08EP0900	VPE4409-08EPA0900	
1000	40"	216	798	VPE4408-08EP1000	VPE4408-08EPA1000	VPE4409-08EP1000	VPE4409-08EPA1000	
1200	48"	276	1180	VPE4408-08EP1200	VPE4408-08EPA1200	VPE4409-08EP1200	VPE4409-08EPA1200	

VPE4448-08EP | VPE4448-08EPA | VPE4449-08EP | VPE4449-08EPA

PN16

Vanne à papillon entre brides PN16
Wafer type butterfly valve PN16



Corps : Fonte Ductile EN-GJS-400-15 (GGG40)
Papillon : Fonte Ductile EN-GJS-400-15 (GGG40) nickelé ou inox 316
Manchette : EPDM chaleur ou EPDM ACS
Raccordement : Entre brides PN16
Pression de service : 16 bar
Température de service : +130°C (+150°C pointe) / -15°C (-30°C pointe)
Température de service ACS : +110°C (+130°C pointe) / +4°C (-20°C pointe)
Manœuvre : Réducteur à volant avec platine de motorisation ISO

Body: Ductile iron EN-GJS-400-15 (GGG40)
Disc: Ductile iron EN-GJS-400-15 (GGG40) nickel-plated or Stainless steel 316
Sleeve: Heat EPDM
Connection: Wafer type PN16
Working pressure: 16 bar
Working temperature: +130°C (+150°C peak) / -15°C (-30°C peak)
Working temperature for ACS: +110°C (+130°C peak) / +4°C (-20°C peak)
Operation: Gearbox with handwheel and ISO top flange for electric actuator connection



Version ACS pour Eau Potable
ACS certification for Drinking Water



* sans bride centrale du DN350 au DN500 / Without central flange from DN350 to DN500

CE

				Papillon / Disc				
				Fonte ductile / Ductile Iron		Inox 316 / Stainless steel 316		
DN	mm	inch	L (mm)	Kg	Manchette / Seat EPDM CH	Manchette / Seat EPDM	Manchette / Seat EPDM CH	Manchette / Seat EPDM
						ACS		ACS
350 *	14"	76,5	68	VPE4448-08EP0350	VPE4448-08EPA0350	VPE4449-08EP0350	VPE4449-08EPA0350	
400 *	16"	102	89	VPE4448-08EP0400	VPE4448-08EPA0400	VPE4449-08EP0400	VPE4449-08EPA0400	
450 *	18"	114	104	VPE4448-08EP0450	VPE4448-08EPA0450	VPE4449-08EP0450	VPE4449-08EPA0450	
500 *	20"	130	126	VPE4448-08EP0500	VPE4448-08EPA0500	VPE4449-08EP0500	VPE4449-08EPA0500	
600	24"	151	222	VPE4448-08EP0600	VPE4448-08EPA0600	VPE4449-08EP0600	VPE4449-08EPA0600	
700	28"	163	336	VPE4448-08EP0700	VPE4448-08EPA0700	VPE4449-08EP0700	VPE4449-08EPA0700	
800	32"	188	431	VPE4448-08EP0800	VPE4448-08EPA0800	VPE4449-08EP0800	VPE4449-08EPA0800	
900	36"	203	548	VPE4448-08EP0900	VPE4448-08EPA0900	VPE4449-08EP0900	VPE4449-08EPA0900	
1000	40"	216	798	VPE4448-08EP1000	VPE4448-08EPA1000	VPE4449-08EP1000	VPE4449-08EPA1000	
1200	48"	276	1180	VPE4448-08EP1200	VPE4448-08EPA1200	VPE4449-08EP1200	VPE4449-08EPA1200	

VPE4438-084EP I VPE4439-084EP

ASA 150

Vanne à papillon entre brides - ASA 150

Wafer type butterfly valve - ASA150



CE



Corps : Fonte Ductile EN-GJS-400-15 (GGG40)
 Papillon : Fonte Ductile EN-GJS-400-15 (GGG40) nickelé ou Inox 316
 Manchette : EPDM CH
 Raccordement : Entre brides ASA 150
 Pression de service max : 16 bar
 Température de service max : +130°C (+150°C pointe)
 Température minimum de service : -15°C (-30°C pointe)
 Manoeuvre : Réducteur à volant avec platine de motorisation ISO

Body: Ductile iron EN-GJS-400-15 (GGG40)
 Disc: Ductile iron EN-GJS-400-15 (GGG40) nickel-plated or Stainless steel 316
 Sleeve: Heat EPDM
 Connection: Wafer type ASA 150
 Max wWorking pressure: 16 bar
 Maximum Working temperature: +130°C (+150°C peak)
 Minimum Working temperature: -15°C (-30°C peak)
 Operation: Gearbox with handwheel and ISO top flange for electric actuator connection



Version ACS pour Eau Potable sur demande
 ACS certification for Drinking Water on request



* sans bride centrale du DN350 au DN500 / Without central flange from DN350 to DN500

				Papillon / Disc	
				Fonte ductile / Ductile Iron	Inox 316 / Stainless steel 316
DN		L (mm)	Kg	Ref.	Ref.
mm	inch				
350 *	14"	76,5	76,5	VPE4438-084EP0350	VPE4439-084EP0350
400 *	16"	102	94	VPE4438-084EP0400	VPE4439-084EP0400
450 *	18"	114	113	VPE4438-084EP0450	VPE4439-084EP0450
500 *	20"	130	120	VPE4438-084EP0500	VPE4439-084EP0500
600	24"	151	215	VPE4438-084EP0600	VPE4439-084EP0600
700	28"	163	382	VPE4438-084EP0700	VPE4439-084EP0700
800	32"	188	475	VPE4438-084EP0800	VPE4439-084EP0800
900	36"	203	795	VPE4438-084EP0900	VPE4439-084EP0900
1000	40"	216	875	VPE4438-084EP1000	VPE4439-084EP1000
1200	48"	276	1170	VPE4438-084EP1200	VPE4439-084EP1200



TECLARGE

DOUBLE BRIDE - SÉRIE 20 DOUBLE FLANGED - SERIES 20

VPE4508-08EP | VPE4508-08EPA | VPE4509-08EP | VPE4509-08EPA

PN10

Vanne à papillon à double bride PN10
Double flanged type butterfly valve - PN10



Corps : Fonte Ductile EN-GJS-400-15 (GGG40)
Papillon : Fonte ductile EN-GJS-400-15 (GGG40) nickelé ou Inox 316
Manchette : EPDM chaleur ou EPDM ACS
Raccordement : À brides PN10
Pression de service : 10 bar
Température de service : +130°C (+150°C pointe) / -15°C (-30°C pointe)
Température de service ACS : +110°C (+130°C pointe) / +4°C (-20°C pointe)
Manœuvre : Réducteur à volant avec platine de motorisation ISO

Body: Ductile iron EN-GJS-400-15 (GGG40)
Disc: Ductile iron EN-GJS-400-15 (GGG40) nickel plated or Stainless steel 316
Sleeve: Heat EPDM or EPDM ACS
Connection: Flanged PN10
Working pressure: 10 bar
Working temperature: +130°C (+150°C peak) / -15°C (-30°C peak)
Working temperature for ACS: +110°C (+130°C peak) / +4°C (-20°C peak)
Operation: Gearbox with handwheel and ISO top flange for electric actuator connection



Version ACS pour Eau Potable
ACS certification for Drinking Water



DN		L (mm)	Kg	Papillon / Disc			
mm	inch			Fonte ductile / Ductile iron		Inox 316 / Stainless steel 316	
				Manchette / Seat EPDM CH	Manchette / Seat EPDM ACS	Manchette / Seat EPDM CH	Manchette / Seat EPDM ACS
350	14"	76,5	55,3	VPE4508-08EP0350	VPE4508-08EPA0350	VPE4509-08EP0350	VPE4509-08EPA0350
400	16"	102	118	VPE4508-08EP0400	VPE4508-08EPA0400	VPE4509-08EP0400	VPE4509-08EPA0400
450	18"	114	143	VPE4508-08EP0450	VPE4508-08EPA0450	VPE4509-08EP0450	VPE4509-08EPA0450
500	20"	127	149	VPE4508-08EP0500	VPE4508-08EPA0500	VPE4509-08EP0500	VPE4509-08EPA0500
600	24"	151	273	VPE4508-08EP0600	VPE4508-08EPA0600	VPE4509-08EP0600	VPE4509-08EPA0600
700	28"	163	431	VPE4508-08EP0700	VPE4508-08EPA0700	VPE4509-08EP0700	VPE4509-08EPA0700
800	32"	188	540	VPE4508-08EP0800	VPE4508-08EPA0800	VPE4509-08EP0800	VPE4509-08EPA0800
900	36"	203	902	VPE4508-08EP0900	VPE4508-08EPA0900	VPE4509-08EP0900	VPE4509-08EPA0900
1000	40"	216	984	VPE4508-08EP1000	VPE4508-08EPA1000	VPE4509-08EP1000	VPE4509-08EPA1000
1200	48"	276	1310	VPE4508-08EP1200	VPE4508-08EPA1200	VPE4509-08EP1200	VPE4509-08EPA1200

VPE4548-08EP | VPE4548-08EPA | VPE4549-08EP | VPE4549-08EPA

PN16

Vanne à papillon à double bride PN16
Double flanged type butterfly valve - PN16



Corps : Fonte Ductile EN-GJS-400-15 (GGG40)
Papillon : Fonte ductile EN-GJS-400-15 (GGG40) nickelé ou Inox 316
Manchette : EPDM chaleur ou EPDM ACS
Raccordement : À brides PN16
Pression de service : 16 bar
Température de service : +130°C (+150°C pointe) / -15°C (-30°C pointe)
Température de service ACS : +110°C (+130°C pointe) / +4°C (-20°C pointe)
Manœuvre : Réducteur à volant avec platine de motorisation ISO

Body: Ductile iron EN-GJS-400-15 (GGG40)
Disc: Ductile iron EN-GJS-400-15 (GGG40) nickel-plated or Stainless steel 316
Sleeve: Heat EPDM or EPDM ACS
Connection: Flanged PN16
Working pressure: 16 bar
Working temperature: +130°C (+150°C peak) / -15°C (-30°C peak)
Working temperature for ACS: +110°C (+130°C peak) / +4°C (-20°C peak)
Operation: Gearbox with handwheel and ISO top flange for electric actuator connection



Version ACS pour Eau Potable
ACS certification for Drinking Water



DN		L (mm)	Kg	Papillon / Disc			
mm	inch			Fonte ductile / Ductile iron		Inox 316 / Stainless steel 316	
				Manchette / Seat EPDM CH	Manchette / Seat EPDM ACS	Manchette / Seat EPDM CH	Manchette / Seat EPDM ACS
350	14"	76,5	55,3	VPE4548-08EP0350	VPE4548-08EPA0350	VPE4549-08EP0350	VPE4549-08EPA0350
400	16"	102	123	VPE4548-08EP0400	VPE4548-08EPA0400	VPE4549-08EP0400	VPE4549-08EPA0400
450	18"	114	146,5	VPE4548-08EP0450	VPE4548-08EPA0450	VPE4549-08EP0450	VPE4549-08EPA0450
500	20"	127	159,5	VPE4548-08EP0500	VPE4548-08EPA0500	VPE4549-08EP0500	VPE4549-08EPA0500
600	24"	151	282	VPE4548-08EP0600	VPE4548-08EPA0600	VPE4549-08EP0600	VPE4549-08EPA0600
700	28"	163	444	VPE4548-08EP0700	VPE4548-08EPA0700	VPE4549-08EP0700	VPE4549-08EPA0700
800	32"	188	555	VPE4548-08EP0800	VPE4548-08EPA0800	VPE4549-08EP0800	VPE4549-08EPA0800
900	36"	203	920	VPE4548-08EP0900	VPE4548-08EPA0900	VPE4549-08EP0900	VPE4549-08EPA0900
1000	40"	216	1005	VPE4548-08EP1000	VPE4548-08EPA1000	VPE4549-08EP1000	VPE4549-08EPA1000
1200	48"	276	1360	VPE4548-08EP1200	VPE4548-08EPA1200	VPE4549-08EP1200	VPE4549-08EPA1200

VPE4538-084EP I VPE4539-084EP

ASA 150

Vanne à papillon à double bride - ASA150

Double flanged type butterfly valve - ASA150



Corps : Fonte Ductile EN-GJS-400-15 (GGG40)
 Papillon : Fonte ductile EN-GJS-400-15 (GGG40) nickelé ou Inox 316
 Manchette : EPDM chaleur
 Raccordement : Entre brides ASA 150
 Pression de service max : 16 bar
 Température de service max : +130°C (+150 °C pointe)
 Température minimum de service : -15°C (-30 °C pointe)
 Manoeuvre : Réducteur à volant avec platine de motorisation ISO

Body: Ductile iron EN-GJS-400-15 (GGG40)
 Disc: Ductile iron EN-GJS-400-15 (GGG40) nickel plated or Stainless steel 316
 Sleeve: Heat EPDM
 Connection: Flanged ASA 150
 Max working pressure: 16 bar
 Maximum Working temperature: +130°C (+150 °C peak)
 Minimum Working temperature: -15°C (-30 °C peak)
 Operation: Gearbox with handwheel and ISO top flange for electric actuator connection



Version ACS pour Eau Potable sur demande
 ACS certification for Drinking Water on request

NEW

				Papillon / Disc	
				Fonte ductile / Ductile iron	Inox 316 / Stainless steel 316
DN		L (mm)	Kg	Ref.	Ref.
mm	inch				
350	14"	76,5	55,3	VPE4538-084EP0350	VPE4539-084EP0350
400	16"	102	118	VPE4538-084EP0400	VPE4539-084EP0400
450	18"	114	143	VPE4538-084EP0450	VPE4539-084EP0450
500	20"	127	149	VPE4538-084EP0500	VPE4539-084EP0500
600	24"	151	273	VPE4538-084EP0600	VPE4539-084EP0600
700	28"	163	431	VPE4538-084EP0700	VPE4539-084EP0700
800	32"	188	540	VPE4538-084EP0800	VPE4539-084EP0800
900	36"	203	902	VPE4538-084EP0900	VPE4539-084EP0900
1000	40"	216	984	VPE4538-084EP1000	VPE4539-084EP1000
1200	48"	276	1310	VPE4538-084EP1200	VPE4539-084EP1200



KIT TECLARGE

MOTORISATION ET RÉDUCTEUR ACTUATOR & DECLUTCHABLE GEARBOX



TECLARGE

MOTEUR AUMA U04 | AUMA ACTUATOR U04

Triphasé | 3-phase

Kit motorisation Auma 3 phases 400V/50Hz On/Off
Electric actuator Auma kit 3-phase 400V/50Hz On/Off



Moteur équipé de :
- 2 contacts fin de course
- 1 résistance de chauffe
- 2 limiteurs de couple
Commande manuelle de secours
Indicateur visuel de position
Protection IP68
Fonction tout ou rien

Actuator equipped with:
- 2 limit switches
- 1 heat resistor
- 2 torque limiters switches included
Emergency handwheel
Visual position indicator
IP68 protection
Function on-off



DN		PN10		PN16	
mm	inch	Type	Ref.	Type	Ref.
350	14"	SA07.2	300160233	SA07.2	300160233
400	16"				
450	18"				
500	20"	SA07.6	300160234	SA07.6	300160234
600	24"				
700	28"	SA07.6	300160235	SA10.2	300160236
800	32"	SA10.2	300160236	SA14.2	300160239
900	36"	SA10.2	300170021	SA14.2	300190054
1000	40"	SA14.2	300190054		
1200	48"	SA14.2	300160237	SA14.2	300160237

MOTEUR BERNARD CONTROLS B04 | B.C ACTUATOR B04

Triphasé | 3-phase

Kit motorisation électrique Bernard Controls 3 phases 400V/50Hz On/Off
Electric actuator Bernard Controls kit 3-phase 400V/50Hz On/Off



Moteur équipé de :
- 2 contacts fin de course
- 1 résistance de chauffe
- 2 limiteurs de couple
Commande manuelle de secours
Indicateur visuel de position
Protection IP68

Actuator equipped with:
- 2 limit switches
- 1 heat resistor
- 2 torque limiters switches
Emergency handwheel
Visual position indicator
IP68 protection



DN		PN10		PN16	
mm	inch	Type	Ref.	Type	Ref.
350	14"	AT3	300200184	AT3	300200184
400	16"	AT3	300200184	AT3	300200184
450	18"	AT3	300200184	AT3	300200184
500	20"	AT3	300200184	AT6	300200185
600	24"	AT6	300200185	AT6	300200185
700	28"	AT6	300200185	AT14	300200186
800	32"	AT14	300200186	AT14	300200186
900	36"	AT14	300200186	AT14	300200186
1000	40"	AT14	300200186	AT25	300200187
1200	48"	AT25	300200187	AT25	300200187

RÉDUCTEUR | MANUAL OVERRIDE DECLUTCHABLE GEAR

Réducteur débrayable | Declutchable gear

Réducteur débrayable et vérin pneumatique double effet
Declutchable gear and double-acting pneumatic actuator



MOA200 à MOA310 : Fonte grise
MOA850 : Fonte grise
TDA : Aluminium

Composé de :
- Actionneur pneumatique double effet
- Réducteur manuel débrayable
- Adaptateur carré
- Vis, rondelle acier Inox A2

MOA30 up to MOA310: Cast Iron
MOA850: Cast Iron
TDA: Aluminium

Comprised of:
- Double-acting pneumatic actuator
- Declutchable gear
- Square adapter
- Stainless steel A2 bolts and nuts



DN		PN10		PN16	
mm	inch	Type	Ref.	Type	Ref.
350	14"	MOA200 + TDA190	300180241	MOA200 + TDA190	300180240
400	16"			MOA200 + TDA210	300180242
450	18"	MOA200 + TDA240	300180243	MOA310 + TDA240	300180244
500	20"	MOA200 + TDA240	300180243	MOA310 + TDA270	300180245
600	24"	MOA310 + TDA270	300180245	MOA850 + TDA350	300180246



Nous ne recommandons pas le montage de réducteur débrayable sur un vérin pneumatique simple effet (en position NO, possibilité en version position NF).
Les volants sont livrés démontés pour l'optimisation de l'envoi. Nous vous invitons à spécifier le montage du volant lors de votre commande si impératif (coût de montage en sus).
We do not recommend mounting the gearbox on a single-acting pneumatic actuator (NO position, NC version on request).
Handwheels are delivered disassembled for the optimization of the shipment. Please contact us if it is imperative that the valve is shipped with handwheel assembled.

ACTIONNEUR PNEUMATIQUE 1/4T

PNEUMATIC ACTUATOR 1/4 T



TECLARGE

Double effet | Double-acting

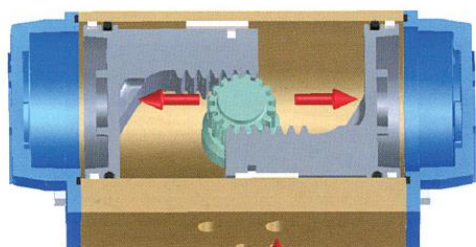

Position ouverte
Opened position

Vue de dessus
Top view

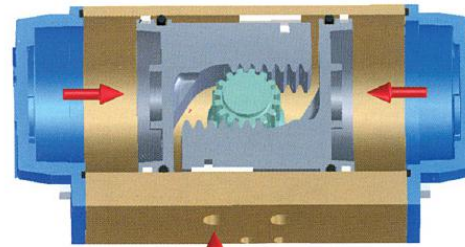

Position fermée
Closed position

KIT DOUBLE EFFET N03 | N03 DOUBLE-ACTING KIT

Kit motorisation pneumatique double effet

Double-acting pneumatic actuator kit

VERIN1/4T



Construction: Aluminium
Pression de service : 6 bar (air lubrifié)
Butées réglables
Livré avec came de position

VSY*



Construction: Aluminium
Working pressure: 6 bar (lubricated air)
Stop bolt retaining nut
Supplied with position cam

*VSY = Scotch and Yoke : Vérin pneumatique haute performance (fort couple à l'ouverture et à la fermeture).
*VSY = Scotch and Yoke : High performance pneumatic actuator (high torque for opening and closing).



ATEX ZONE 1 / 2 / 21 / 22

DN		TECLARGE (ΔP 10 bar)		TECLARGE (ΔP 16 bar)	
		Type	Ref.	Type	Ref.
mm	inch				
350	14"	VERIN1/4T-TDA160	300160240	VERIN1/4T-TDA190	300170011
400	16"	VERIN1/4T-TDA190	300160241	VERIN1/4T-TDA210	300160242
450	18"	VERIN1/4T-TDA210	300160242	VERIN1/4T-TDA240	300170012
500	20"	VERIN1/4T-TDA240	300160243	VERIN1/4T-TDA270	300160250
600	24"	VERIN1/4T-TDA270	300160244	VERIN1/4T-TDA350	300160251
700	28"	VERIN1/4T-TDA300	300160245	VERIN1/4T-TDA350	300160246
800	32"	VERIN1/4T-TDA350	300160246	VERIN1/4T-TDA400	300170013
900	36"	VERIN1/4T-TDA400	300160247	VSY-TDA30-450D75*	300170022
1000	40"	VSY-TDA30-450D85*	300160248	VSY-TDA35-550D85*	300160252
1200	48"	VSY-TDA35-550D105*	300160249	VSY-TDA35-550D105*	300160249

Simple effet | Single-acting

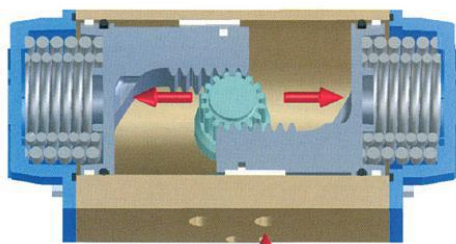

Position ouverte
Opened position

Vue de dessus
Top view

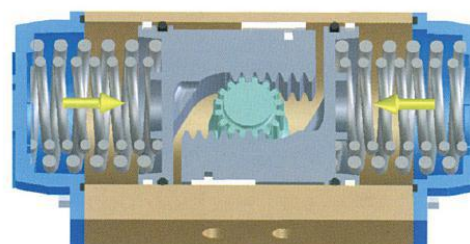

Position fermée
Closed position

KIT SIMPLE EFFET N07 | N07 SINGLE-ACTING KIT

Kit motorisation pneumatique simple effet

Single-acting pneumatic actuator kit



Construction: Aluminium
Pression de service : 6 bar (air lubrifié)
Butées réglables
Livré avec came de position

Construction: Aluminium
Working pressure: 6 bar (lubricated air)
Stop bolt retaining nut
Supplied with position cam



ATEX ZONE 1 / 2 / 21 / 22

DN		TECLARGE (ΔP 10 bar)		TECLARGE (ΔP 16 bar)	
		Type	Ref.	Type	Ref.
mm	inch				
350	14"	VERIN1/4T-TSR240	300160253	VERIN1/4T-TSR270	300170014
400	16"	VERIN1/4T-TSR270	300160254	VERIN1/4T-TSR350	300170015
450	18"	VERIN1/4T-TSR300	300160255	VERIN1/4T-TSR400	300160258
500	20"	VERIN1/4T-TSR350	300160256	VERIN1/4T-TSR400	300170016
600	24"	VERIN1/4T-TSR400	300160257		



KIT COLONNETTE DROITE POUR TECLARGE

PEDESTAL FLOOR MOUNTING KIT FOR TECLARGE BUTTERFLY VALVES

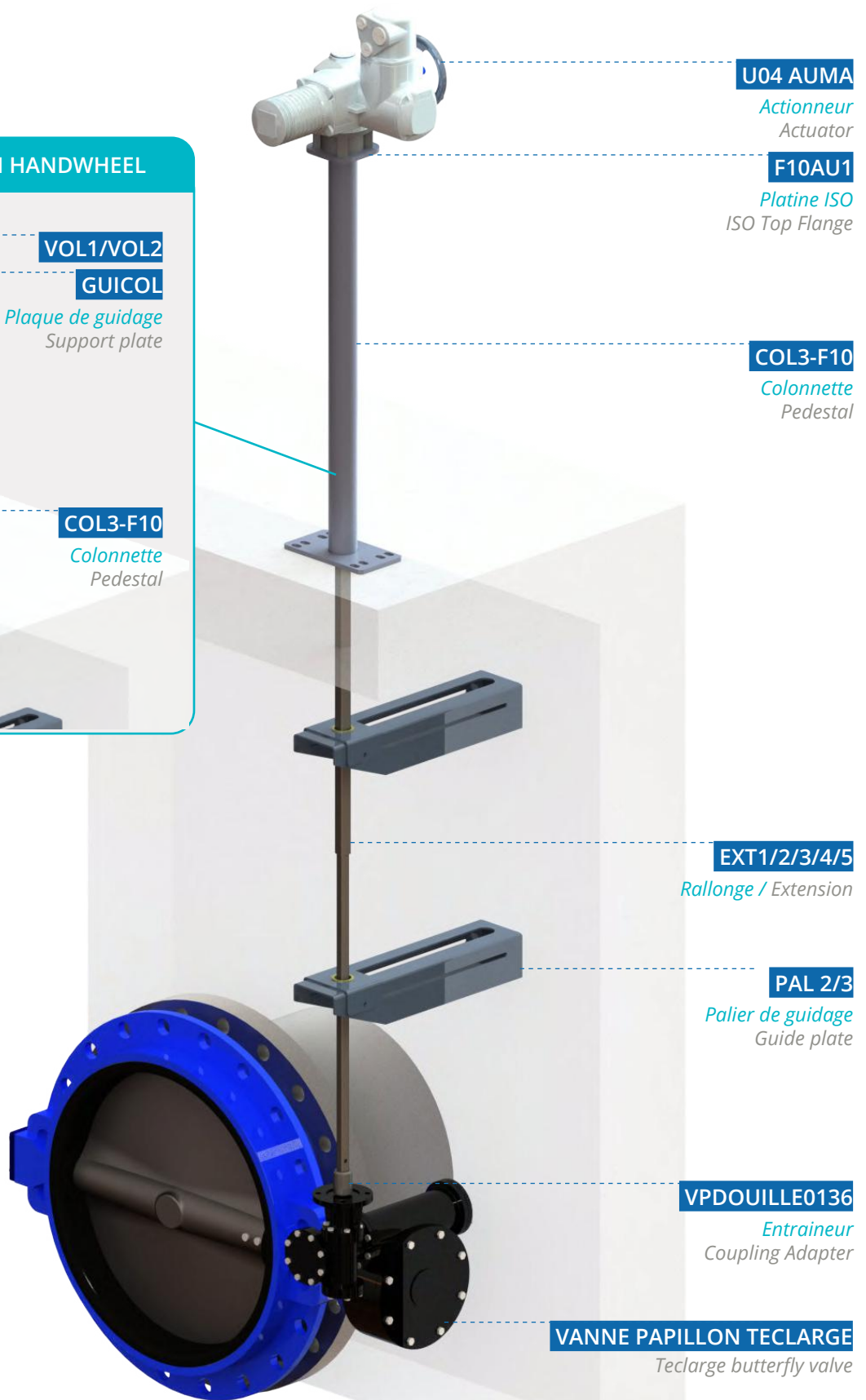
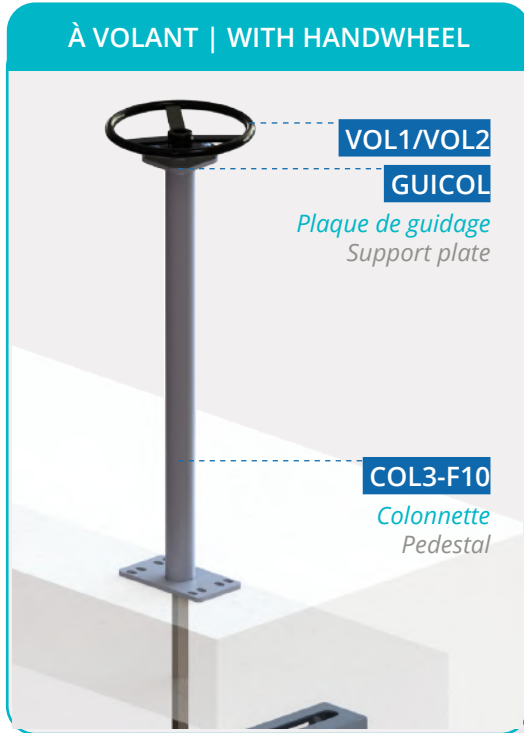

Représentation à titre indicatif (contre-bridés et tirants non représentés, ils sont obligatoires dans toutes installations).
Representation for reference only (counter flanges and tie rods not shown are required in all installations).

KIT COLONNETTE MURALE POUR TECLARGE

PEDESTAL WALL MOUNTING KIT FOR TECLARGE BUTTERFLY VALVES

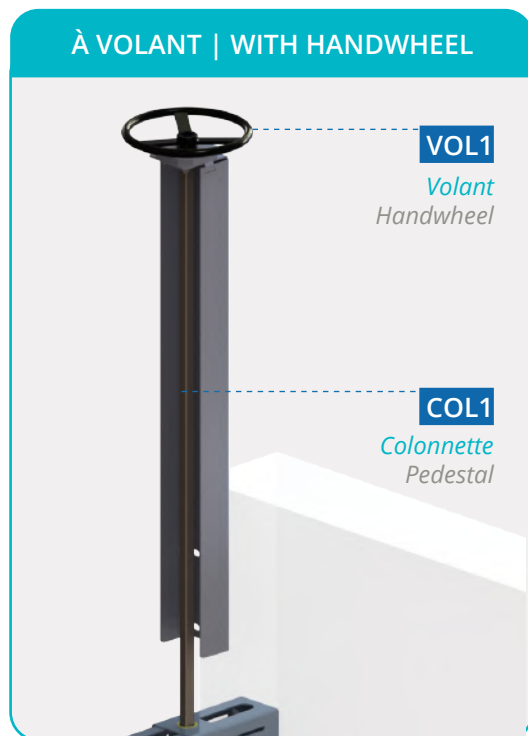

La distance entre le mur et les colonnettes murales (COL1-COL2) n'est pas réglable. Prévoir un déport avec le mur ou un système pour plaquer la colonne à la bonne distance.

The distance between the wall and the wall column (COL1-COL2) is not adjustable, provide an offset with the wall or a system to place the column at the right distance.

VPDOUILLE0136

Entraîneur
Coupling adapter

VANNE PAPILLON TECLARGE

Teclarge butterfly valve

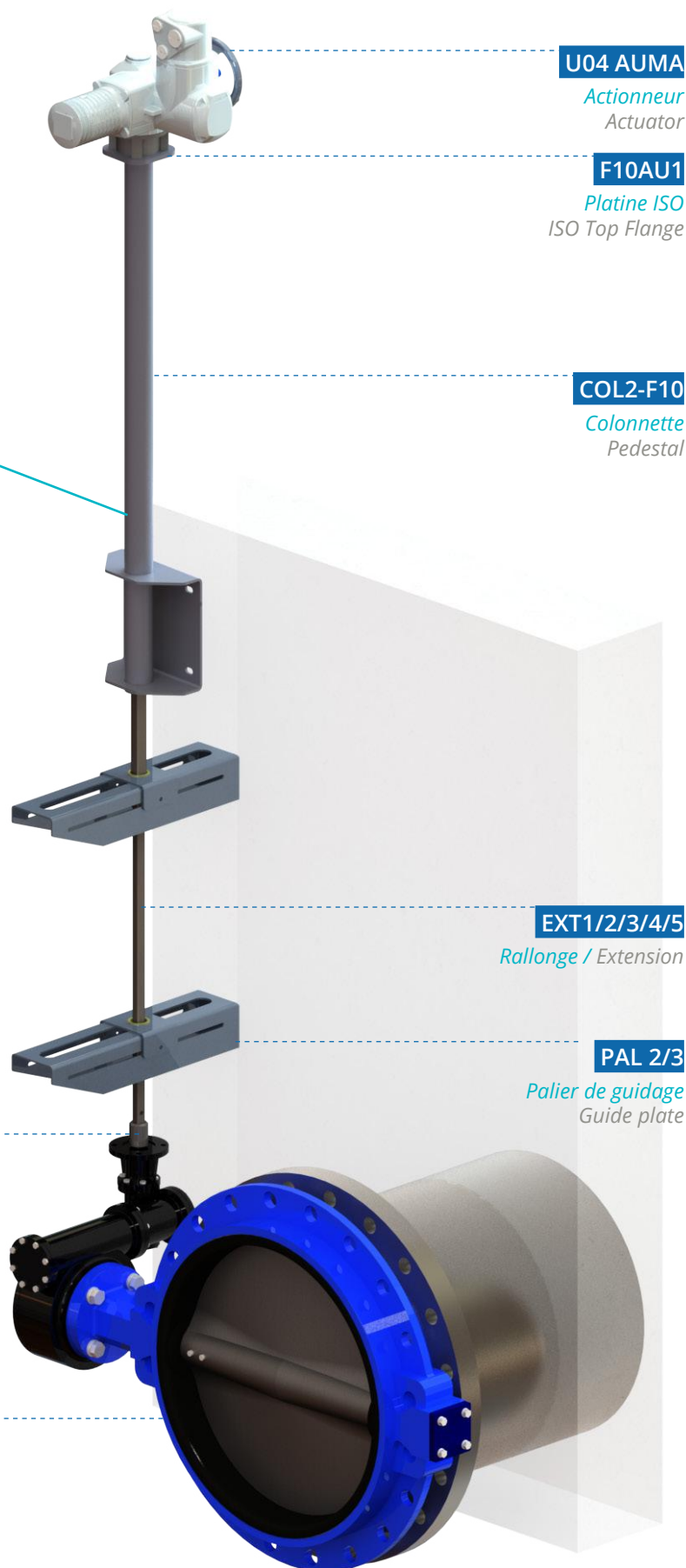

Représentation à titre indicatif (contre-brides et tirants non représentés, ils sont obligatoires dans toutes installations).
Representation for reference only (counter flanges and tie rods not shown are required in all installations).



TRINGLERIES POUR MONTAGE SUR COLONNETTE - TECLARGE
LINKAGE FOR PEDESTAL MOUNTED - TECLARGE



TECLARGE

ENTRAINEUR | COUPLING ADAPTER

Entraîneur Femelle pour tige de rallonge (EXT)
Female coupling adapter for extension (EXT)



Matière : Inox 304

Material: Stainless Steel 304

Ref.	DN
VPDOUILLE0136	350-600

RALLONGE | EXTENSION

Rallonge télescopique
Telescopic extension



Matière : Inox 316L

Material: Stainless Steel 316L

Dimension (mm)	Ref.
800-1100	EXT1
1100-1750	EXT2
1750-3000	EXT3
3000-5500	EXT4
4000-8000	EXT5

PALIER DE GUIDAGE | GUIDE PLATE

Palier de guidage fixe pour rallonge télescopique
Guide plate for telescopic extension



Matière : Inox 316L

Material: Stainless Steel 316L

Dimension (mm)	Ref.
70-200	PAL2
70-500	PAL3



Mettre obligatoirement un palier tous les deux mètres + un autre avant le passage dans la colonnette.
Place one guide plate every two meters of the extension + one guide plate just before the pedestal floor.

COLONNETTE | PEDESTAL

Colonnette mécano-soudée pour vannes à papillon
Mechanically welded pedestal for butterfly valves

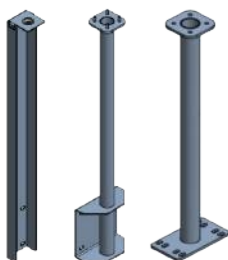

1 2 3



COL1 : pour commande par volant et fixation murale
COL2-F10 : pour commande motorisée et fixation murale
COL3-F10 : pour fixation au sol

Matière : Inox 304
Hauteur fixe : 900mm

Pedestal wall mounted for handwheel
Pedestal wall mounted for electric actuator
Pedestal floor mounted

Material: Stainless Steel 304
Height: 900mm

Ref.
COL1
COL2-F10
COL3-F10

PLAQUE DE GUIDAGE | SUPPORT PLATE

Plaque de guidage pour colonnette fixation sol et commande par volant
Support plate for pedestal floor mounting handwheel



Matière : POM

Material: POM

Ref.
GUICOL

Permet de guider la rallonge
Used to guide the extension



A utiliser obligatoirement en cas de commande par volant sur colonnette COL3-F10.
To use only with handwheel operation on pedestal COL3-F10.

VOLANT I HANDWHEEL

Volant
Handwheel

Matière : Acier revêtu Epoxy
VOL1 : Diamètre 300mm
VOL2 : Diamètre 500mm

Material: Epoxy-coated carbon steel
VOL1: Diameter 300mm
VOL2: Diameter 500mm

Ref.	DN	
	mm	inch
VOL1	50-300	2"-12"
VOL2	350-600	14"-24"



Adaptable sur extension
Adaptable with extension

PLATINE ISO POUR MOTEUR I ISO TOP FLANGE FOR ACTUATOR

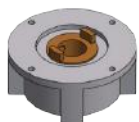
Platine pour moteur Auma
Output drive F10 for Auma electric actuator on extension

Matière : Fonte, écrou en bronze
Platine : ISO5210
Pour montage sur colonette

Material: Cast iron, bronze nut
Top mounted flange: ISO5210
For assembly on column

Ref.

F10AU1



Pour accouplement entre colonnette et moteur Auma
Coupling between the column and the Auma actuator

U04 - MOTEUR TECLARGE - COLONNETTE I AUMA ACTUATOR FOR PEDESTAL MOUNTED TECLARGE

Motorisation Auma 3 phases 400V/50Hz On/Off
Auma actuator 3 phases 400V/50Hz On/Off

Moteur équipé de :
- 2 contacts fin de course
- 1 résistance de chauffe
- 2 limiteurs de couple
Commande manuelle de secours
Indicateur visuel de position
Protection IP68

Actuator equipped with:
- 2 limit switches
- 1 heat resistor
- 2 torque limiters switches included
Emergency handwheel
Visual position indicator
IP68 protection

PN10 / PN16			
mm	DN		Ref.
	inch		
350-500	14"-20"		SA07.2-U04B1TOR63
600	24"		SA07.6-U04B1TOR63



OPTIONS TECFLY - TECLARGE



VPI



TECLARGE

Boîtier fin de course MONTAGE SUR VERIN PNEUMATIQUE | Limit switch MOUNTING ON PNEUMATIC ACTUATOR

Les boîtiers fin de course sont des boîtiers dans lesquels sont intégrés des contacts inductifs ou des contacts mécaniques qui permettent de récupérer une information électrique de la position d'une vanne. Ces boîtiers sont adaptés en fonction de l'environnement dans lequel ils sont installés.

On the limit switch box there are integrated inductive contacts or mechanical contacts which allow electrical information to be retrieved from the position of the valve. These boxes are adapted according to the environment in which they are installed.

BOITIER FIN DE COURSE TECOFI | TECOFI LIMIT SWITCH BOX

Boîtier fin de course TECOFI pour vérin pneumatique - Non ATEX
TECOFI limit switch box for pneumatic actuator - Non-ATEX



Tecofi
VALVE DESIGNER - FRANCE



Protection IP68
Construction : Fonte d'aluminium
Indicateur visuel de position en polycarbonate

IP68 protection
Material: Cast aluminium
Polycarbonate visual position indicator

Montage sur toute la gamme de vérin 1/4T (TDA / TSR)
Adapted for all pneumatic actuator types 1/4T (TDA / TSR)

Ref.

300180034



Visserie, axe et arcade de montage en Inox 304 inclus.
Facile à installer et robuste.
Stainless Steel 304 screws, axis and mounting arch.
Easy to install and resistant.

Gamme TOPWORX | TOPWORX range

*Ces kits contiennent le boîtier fin de course et le kit de montage nécessaire (montage NAMUR)
*These kits contain the limit switch box and the necessary mounting kit (NAMUR mounting)

- ✓ Compact : usage optimal de l'espace
- ✓ Conception ingénieuse de la came : accès facile et précis du réglage
- ✓ Identification rapide des contacteurs
- ✓ Montage direct : hauteur réduite, accessoires de montage limités

- ✓ Compact: optimized use of space
- ✓ Unique cam design: easy access and accurate setting or sensor position
- ✓ Quick identification of open/closed switches
- ✓ Direct-mounting feature: reducing height, avoiding expensive mounting brackets

TVA-E2WGNM | TVA-M20GNM - BOITIER FIN DE COURSE | LIMIT SWITCH BOX

Boîtier fin de course inductif TopWorx
Inductive TOPWORX limit switch box



TOPWORX
by
EMERSON



BOITIER SERIE TVA :
Coque et couvercle en résine
IP 68
Affichage visuel standard vert "ouvert" / rouge "fermé"
Arbre NAMUR
Connexion en entrée de boîtier M20
Joints silicone
Kit de montage

TVA SERIES BOX:
Composite resin body and cover
IP 68
Intuitive colors green OPEN, red CLOSED
NAMUR shaft
M20 Box entry connection
Silicone O-rings
Mounting kit



ATEX Zone 1/T6

Non ATEX 2 capteurs inductifs NAMUR 8V p+f NJ2-V3-N inductive NAMUR 8V p+f NJ2-V3-N				ATEX ZONE 1 / T6 (Ex ia) 2 contacts mécaniques / mechanical			
Vérin simple effet / Single acting		Vérin double effet / Double acting		Vérin simple effet / Single acting		Vérin double effet / Double acting	
Type	Ref.	Type	Ref.	Type	Ref.	Type	Ref.
TSR-063	300200120 (30x80*)	TDA - 052	300200120 (30x80*)	TSR-063	300200122 (30x80*)	TDA - 052	300200122 (30x80*)
TSR-063		TDA - 052		TSR-063		TDA - 052	
TSR-083		TDA - 063		TSR-083		TDA - 063	
TSR-092		TDA - 063		TSR-092		TDA - 063	
TSR-105		TDA - 083		TSR-105		TDA - 083	
TSR-125	300200121 (30x130*)	TDA - 083	300200121 (30x130*)	TSR-125	300200123 (30x130*)	TDA - 083	300200123 (30x130*)
TSR-140		TDA - 092		TSR-140		TDA - 092	
TSR-160		TDA - 125		TSR-160		TDA - 125	
TSR-190		TDA - 140		TSR-190		TDA - 140	
TSR-210		TDA - 160		TSR-210		TDA - 160	

TXP-E2CGNMM - BOITIER FIN DE COURSE ATEX | ATEX LIMIT SWITCH BOX

Inductif | Inductive

Boîtier fin de course inductif TopWorx
Inductive TOPWORX limit switch box

BOITIER SERIE TXP :
Coque et couvercle en aluminium tropicalisé
2 capteurs inductifs NAMUR 8V p+f NJ2-V3-N
IP 67
Affichage visuel standard vert "ouvert" / rouge
"fermé"
Arbre NAMUR
Connexion en entrée de boîtier M20
Joints silicone
Kit de montage

VAT SERIES BOX:
Body and cover composite resin
2 inductifs contacts NAMUR 8V p+f NJ2-V3-N
IP 67
Intuitive colors green OPEN, red CLOSED
NAMUR shaft
M20 Box entry connection
Silicone O-rings
Mounting kit

ATEX Zone 1/21 T6/T85°C
Ex db - Ex tb

NEW

Vérin simple effet / Single-Acting		Vérin double effet / Double-Acting	
Type	Ref.	Type	Ref.
TSR-063	300200126 (30x80*)	TDA - 052	300200126 (30x80*)
TSR-063		TDA - 052	
TSR-083		TDA - 063	
TSR-092		TDA - 063	
TSR-105		TDA - 083	
TSR-125	300200127 (30x130*)	TDA - 083	300200127 (30x130*)
TSR-140		TDA - 092	
TSR-160		TDA - 125	
TSR-190		TDA - 140	
TSR-210		TDA - 160	



Résiste aux environnements difficiles grâce à sa conception étanche et robuste.
Resistant in harsh conditions thanks to its seal and robust design.

TVL-M20GNMM - BOITIER FIN DE COURSE ATEX | ATEX LIMIT SWITCH BOX

Mécanique | Mechanical

Boîtier fin de course mécanique TopWorx
TOPWORX mechanical limit switch box

BOITIER SERIE TVL :
Coque et couvercle en aluminium tropicalisé
2 contacts mécaniques secs : 15A/120VCA -
SPDT
IP 68
Affichage visuel standard vert "ouvert" / rouge
"fermé"
Arbre NAMUR
Connexion en entrée de boîtier M20
Joints silicone
Kit de montage

TVL SERIES BOX:
Body and cover composite resin
2 dry mechanical contacts: 15A/120VAC - SPDT
IP 68
Intuitive colors green OPEN, red CLOSED
NAMUR shaft
M20 Box entry connection
Silicone O-rings
Mounting kit

ATEX Zone 1/21 T6/T75°C
(Ex ia - Ex tb)

NEW

Vérin simple effet / Single-Acting		Vérin double effet / Double-Acting	
Type	Ref.	Type	Ref.
TSR-063	300200124 (30x80*)	TDA - 052	300200124 (30x80*)
TSR-063		TDA - 052	
TSR-083		TDA - 063	
TSR-092		TDA - 063	
TSR-105		TDA - 083	
TSR-125	300200125 (30x130*)	TDA - 083	300200125 (30x130*)
TSR-140		TDA - 092	
TSR-160		TDA - 125	
TSR-190		TDA - 140	
TSR-210		TDA - 160	



KIT DOUBLE DETECTEUR INDUCTIF | DOUBLE INDUCTIVE KIT DETECTOR

Kit double détecteur inductif pour vanne 1/4T pneumatique
Double inductive detector kit for 1/4T pneumatic actuated valves



Composé de :

- Double détecteur inductif IFM M12
- Connecteur coudé F + câble 2m
- Came porte drapeau + platine de montage

Actuator equipped with:

- Double inductive detector IFM M12
- Female elbow connector + 2m cable
- Case / Contact limit

NEW

Type de vérin / Actuator type	Ref.
TDA / TSR052 --> TDA / TSR105	300190336
TDA / TSR 125 --> TDA / TSR400	300190337



Type	Ref.
IFM M12	IF5225-M12

KIT D'AUTOMATISATION AS-INTERFACE | AS-INTERFACE KIT

Kit AS-I Bus pour vérin pneumatique
AS-Interface automation kit for pneumatic actuator



Composé de :

- 1 détecteur double avec connexion pour électrovannes
- 1 came porte-drapeaux
- 1 pièce d'écartement
- 1 électrodistributeur Norgreen Herion
- 2 silencieux plastique
- 1 câble de connexion
- 1 prise vampire

Comprised of:

- 1 dual sensor with connection for solenoid valves
- 1 target puck
- 1 spacer
- 1 Norgreen Herion solenoid valve
- 2 plastic silencers
- 1 cable connector
- 1 insulation displacement connector

NEW

Type de vérin Actuator type	Ref.
TDA/TSR052 --> TDA/TSR105	401200030
TDA/TSR 125 --> TDA/TSR400	401200031



- ✓ Le bus AS-I permet de diminuer le nombre de câbles nécessaire à l'utilisation d'un grand nombre de capteurs ou de pré-actionneurs : ces derniers sont reliés directement ou par l'intermédiaire d'une embase à l'automate central via 1 seul câble.
- ✓ Chaque embase permet de connecter jusqu'à 4 capteurs ou pré-actionneurs au bus.
- ✓ Le bus AS-I permet d'utiliser jusqu'à 31 embases, soit 124 capteurs (plus sur demande), tout en conservant un temps de réaction très faible (soit 5ms).
- ✓ La longueur maximale d'un segment AS-I est de 100m (au-delà sur demande).

- ✓ The AS-I bus reduces the number of cables required to install a large number of sensors or pre-actuators: these are connected directly or via the central PLC baseplate via a single cable.
- ✓ Each baseplate allows up to 4 sensors or pre-actuators to be connected to the bus.
- ✓ The AS-I bus allows up to 31 baseplates to be used, being 124 sensors (more on request), all while maintaining a low reaction time (5ms).
- ✓ The maximum length of a AS-I segment is 100m (more on request).



Electrodistributeur NON ATEX | NON ATEX solenoid valve

ELECTRODISTRIBUTEUR NAMUR NON ATEX I NON-ATEX

Monostable

Electrodistributeur ASCO monostable G551A001MS montage namur NON ATEX pour vérin simple et double effet
 ASCO NON-ATEX solenoid valve monostable G551A001MS namur for controlling double-acting and single-acting actuator



Commande électropneumatique
 (avec commande manuelle)
 3/2 NF – 5/2 rappel ressort
 Raccordement NAMUR G1/4"
 Bobine époxy
 IP 65
 Aluminium anodisé noir
 Pression différentielle : 2 – 10 bar
 Plage de température : -25°C / +60°C
 Débit : 700L/min à 6 bar

Electro-pneumatic control
 (with manual override)
 3/2 NF – 5/2 spring return
 Connection NAMUR G1/4"
 Epoxy coil
 IP 65
 Anodized aluminium
 Differential pressure: 2-10bar
 Temperature range: -25°C / +60°C
 Flow rate: 700L/min at 6 bar

Voltage	Ref.
24VAC	300180062
24VCC	300180063
48VAC	300180064
48VCC	300180065
230VAC	300180066

ELECTRODISTRIBUTEUR NAMUR GRAND DÉBIT NON ATEX I NON-ATEX HIGH FLOW

Monostable

Electrodistributeur ASCO monostable G553A001S3 montage namur NON ATEX pour vérin simple et double effet
 ASCO NON-ATEX solenoid valve monostable G553A001S3 namur for controlling double-acting and single-acting actuator



Commande électropneumatique
 (avec commande manuelle)
 3/2 NF – 5/2 rappel ressort
 Raccordement NAMUR G1/2"
 Bobine époxy
 IP 65
 Aluminium anodisé noir
 Pression différentielle : 2 – 10 bar
 Plage de température : -25°C / +60°C

Electro-pneumatic control
 (with manual override)
 3/2 NF – 5/2 spring return
 Connection NAMUR G1/2"
 Epoxy coil
 IP 65
 Anodized aluminium
 Differential pressure: 2-10bar
 Temperature range: -25°C / +60°C

Voltage	Ref.
24VAC/50-60 Hz	G553A001S3AN
24VCC	G553A001S3D2
48VAC/50-60 Hz	G553A001S3AP
48VCC	G553A001S3D3
115VAC/50 Hz	G553A001S3A5
230VAC/50 Hz	G553A001S3A8

POUR MODELES A PARTIR DU TDA240 et TSR240
 For models from the TDA240 and TSR240



Electrodistributeur grand débit : 3000L/min (à 6 bar)
 High flow solenoid valve : 3000L/min (at 6 bar)

ELECTRODISTRIBUTEUR NAMUR NON ATEX I NON-ATEX NAMUR SOLENOID VALVE

Bistable

Electrodistributeur ASCO bistable G551A002 G1/4 montage namur NON ATEX pour vérin simple et double effet
 ASCO NON-ATEX solenoid valve bistable G551A002M G1/4 namur for controlling double-acting and single-acting actuator



Commande électropneumatique
 (avec commande manuelle)
 3/2 NF – 5/2 rappel ressort
 Raccordement NAMUR G1/4"
 Bobine époxy
 IP 65
 Aluminium anodisé noir
 Pression différentielle : 2 – 10 bar
 Plage de température : -25°C / +60°C
 Débit : 700L/min à 6 bar

Electro-pneumatic control
 (with manual override)
 3/2 NF – 5/2 spring return
 Connection NAMUR G1/4"
 Epoxy coil
 IP 65
 Anodized aluminium
 Differential pressure: 2-10bar
 Temperature range: -25°C / +60°C
 Flow rate: 700L/min at 6 bar

Voltage	Ref.
24VAC	G551A002MS.24/50-60
24VDC	G551A002MS.24/DC
48VAC	G551A002MS.48/50-60
48VDC	G551A002MS.48/DC
230VAC	G551A002MS.230/50

ELECTRODISTRIBUTEUR NAMUR GRAND DEBIT NON ATEX I NON-ATEX NAMUR HIGH FLOW SOLENOID VALVE

Bistable

Electrodistributeur ASCO bistable G553A002 G1/2 montage namur NON ATEX pour vérin simple et double effet
 ASCO NON-ATEX solenoid valve bistable G1/2 namur G553A002 for controlling double-acting and single-acting actuator



Commande électropneumatique
 (avec commande manuelle)
 3/2 NF – 5/2 rappel ressort
 Raccordement NAMUR G1/2"
 Bobine époxy
 IP 65
 Aluminium anodisé noir
 Pression différentielle : 2 – 10 bar
 Plage de température : -25°C / +60°C

Electro-pneumatic control
 (with manual override)
 3/2 NF – 5/2 spring return
 Connection NAMUR G1/2"
 Epoxy coil
 IP 65
 Anodized aluminium
 Differential pressure: 2-10bar
 Temperature range: -25°C / +60°C

Voltage	Ref.
24VAC	G553A002MS.24/50-60
24VDC	G553A002MS.24/DC
48VAC	G553A002MS.48/50-60
48VDC	G553A002MS.48/DC
230VAC	G553A002MS.230/50

POUR MODELES A PARTIR DU TDA240 et TSR240
 For models from the TDA240 and TSR240



Electrodistributeur grand débit : 3000L/min (à 6 bar)
 High flow solenoid valve : 3000L/min (at 6 bar)



Electrodistributeur ATEX | ATEX solenoid valves

Voir guide technique page 341
See technical guide on page 341

Des produits conformes à la directive ATEX 2014/34/UE

Products compliant with the ATEX directive 2014/34/EU

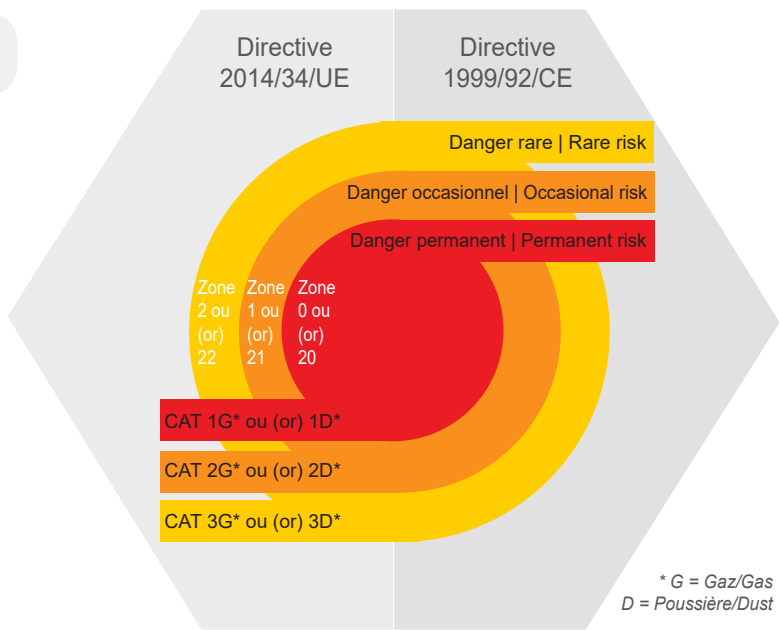
ELECTRODISTRIBUTEUR NAMUR ATEX | ATEX NAMUR SOLENOID VALVE

Monostable

Electrodistributeur ASCO monostable namur ATEX pour vérin simple et double effet
ASCO ATEX solenoid valve monostable namur for controlling double-acting and single-acting actuator

NEW



Commande électropneumatique (sans commande manuelle)
3/2 NF - 5/2 rappel ressort
Raccordement NAMUR G1/4
Distributeur avec bobine époxy ATEX IP65
Aluminium anodisé noir
Pression différentielle : 2-10bar
Plage de température : -10°C / +50°C
Débit : 700L/min
Protection Ex tc

Electro-pneumatic control (without manual override)
3/2 NF - 5/2 spring return
Connection NAMUR G1/4
Distributor with ATEX epoxy coil IP65
Anodized aluminium
Differential pressure: 2-10bar
Temperature range: -10°C / +50°C
Flow rate: 700L/min
Ex tc protection

Voltage	Ref.
24VDC	SGG551A001.24/DC
230VAC	SGG551A001.230/50-60

3G T4 Zone 2
3D T115°C Zone 22

ELECTRODISTRIBUTEUR NAMUR ATEX | ATEX NAMUR SOLENOID VALVE

Monostable

Electrodistributeur ASCO monostable namur ATEX pour vérin simple et double effet
ASCO ATEX solenoid valve monostable namur for controlling double-acting and single-acting actuator

NEW



Commande électropneumatique (sans commande manuelle)
3/2 NF - 5/2 rappel ressort
Raccordement NAMUR G1/4
Distributeur avec bobine intégrée dans un boîtier aluminium antidéflagrant IP67
Pression différentielle : 2-10bar
Plage de température : -25°C / +60°C
Débit : 700L/min
Protection Ex d et Ex tb

Electro-pneumatic control (without manual override)
3/2 NF - 5/2 spring return
Connection NAMUR G1/4
Distributor with coil integrated in an explosion proof aluminium box IP67
Differential pressure: 2-10bar
Temperature range: -25°C / +60°C
Flow rate: 700L/min
Protection Ex d and Ex tb

Voltage	Ref.
24VDC	LPKFG551B301.24/DC
230VAC	LPKFG551B301.230/50

2G T6 Zone 1
2D T135°C Zone 21

ELECTRODISTRIBUTEUR NAMUR ATEX | ATEX NAMUR SOLENOID VALVE

Monostable

Electrodistributeur ASCO monostable namur ATEX pour vérin simple et double effet
ASCO ATEX solenoid valve monostable namur for controlling double-acting and single-acting actuator



Commande électropneumatique (sans commande manuelle)
 3/2 NF - 5/2 rappel ressort
 Raccordement NAMUR G1/4
 IP65
 Pression différentielle : 2-10 bar
 Plage de température : -25°C +60°C
 Débit : 700L/min
 Sécurité intrinsèque Ex ia et Ex ib

Electro-pneumatic control (without manual override)
 3/2 NF - 5/2 spring return
 Connection NAMUR G1/4
 IP65
 Differential pressure: 2-10bar
 Temperature range: -25°C / +60°C
 Flow rate: 700L/min
 Intrinsic safety Ex ia et Ex ib

Voltage	Ref.
24VDC	LISCG551B201.24/DC



2G T6 Zone 1
2D T85°C Zone 21

SILENCIEUX | SILENCER

Silencieux d'échappement pour électrodistributeur réglable
Silencer for solenoid valve



Corps : Laiton
 Raccordement : Fileté BSP

 Body: Brass
 Connection: Male BSP



Réduit le bruit d'échappement à la sortie de l'air.
Decrease the exhaust noise at the air outlet.

DN	Ref.
1/8"	EDSILENCE-0005
1/4"	EDSILENCE-0008

FREIN | THROTTLE

Frein d'échappement pour électrodistributeur
Adjustable throttle valve for solenoid valve



Construction: Laiton

 Construction: Brass



Réduit le temps de manoeuvre des vannes (ouverture et/ou fermeture)
Slows the valve's operating time (opening and/or closing)

DN	Ref.
1/8"	EDFREIN-0005
1/4"	EDFREIN-0008



Traitement d'air | Air treatment

REGULATEUR | REGULATOR

Régulateur pour air comprimé
Regulator for compressed air



Corps : Aluminium
 Tube : Polycarbonate
 Température de service : -10/+60°C
 Pression de service : 0,5 à 10 bar
 Précision du régulateur : 0,2 bar
 Raccordement : Femelle BSP
 Avec manomètre et support
 Voir les courbes de débits (L/min) selon la pression d'entrée et de sortie sur le passeport technique.

Body: Aluminium
 Tube: Polycarbonate
 Working temperature: -10/+60°C
 Working pressure: 0,5 to 10 bar
 Regulator precision: 0,2 bar
 Connection: BSP threaded ends
 With pressure gauge and mounting kit
 Consult the technical data sheet for the flows curve.

DN	Ref.
1/4"	FRL1733-0008
3/8"	FRL1733-0010
1/2"	FRL1733-0015

FILTRE REGULATEUR | REGULATOR FILTER

Filtre régulateur pour air comprimé
Filter + regulator for compressed air



Corps : Aluminium
 Tube : Polycarbonate
 Filtration : 5µ
 Température de service : 0/+50°C
 Pression de service : 1/4"-1/2" : 10 bar
 3/4"-1" : 12 bar
 1 cartouche de filtration

Body: Aluminium
 Tube: Polycarbonate
 Filtration: 5µ
 Working temperature: 0/+50°C
 Working pressure: 1/4"-1/2": 10 bar
 3/4"-1": 12 bar
 1 filter cartridge

DN	Ref.
1/4"	FRL1731-0008
3/8"	FRL1731-0010
1/2"	FRL1731-0015



FILTRE REGULATEUR LUBRIFICATEUR | LUBRICATOR FILTER REGULATOR

Lubrificateur | Lubricator

Filtre régulateur et lubrificateur pour air comprimé
Lubricator filter + regulator for compressed air



Corps : Aluminium
Tube : Polycarbonate
Filtration : 5µ
Température de service : 0/+50°C
Pression de service : 1/4"-1/2" : 10 bar
3/4"-1" : 12 bar
2 cartouches de filtration

Body: Aluminium
Tube: Polycarbonate
Filtration: 5µ
Working temperature: 0/+50°C
Working pressure: 1/4"-1/2": 10 bar
3/4"-1": 12 bar
2 filter cartridges

DN	Ref.
1/4"	FRL1730-0008
3/8"	FRL1730-0010
1/2"	FRL1730-0015



Faible encombrement. Garantie un apport d'air lubrifié de qualité et assure le rendement des équipements.
Small footprint, low mass. Guarantees quality lubricated air supply and ensures the performance of the equipment.



Electropositionneurs numériques | Digital electropositioners

Permet la régulation de position de vannes actionnées par des vérins pneumatiques 1/4 tour.

Allow the position regulation of valves actuated by pneumatic actuators 1/4 turn.

- ✓ Simplicité de montage
- ✓ Qualité de régulation élevée
- ✓ Faible consommation d'air comprimé
- ✓ Insensible aux vibrations (faibles masses en mouvement)
- ✓ Disponible pour vérins DE et SE, en atmosphère non explosive ou explosive (ATEX)

- ✓ Simple assembly
- ✓ High regulation quality
- ✓ Low compressed air consumption
- ✓ Resistant to vibrations (low moving masses)
- ✓ Available for DA and SA actuators, in non-explosive or potentially explosive atmosphere (ATEX)

Double effet | Double-acting



Un électropositionneur peut coûter jusqu'à 20% de son prix d'achat par an en air comprimé! Le modèle SIPART de Siemens® offre une faible consommation d'air (36 NI/h) ce qui le place parmi le meilleur du marché.
An electro pneumatic positioner can cost up to 20% of its purchase price in compressed air per year! The Siemens SIPART® offers low air consumption (36NI/h), placing it as one of the best on the market.

ELECTROPOSITIONNEUR POUR VERIN DOUBLE EFFET | ELECTROPOSITIONER FOR DOUBLE-ACTING ACTUATOR

Electropositionneur numérique modèle SIEMENS® SIPART - PS2 pour vérin double effet type TDA
SIEMENS electropositioner type SIPART - PS2 for double-acting TDA actuator type



Type : Electro-pneumatique pour vérin double effet
Température de fonctionnement : -30°C/+80°C
Pression d'alimentation : 1,4 à 7 bar.
Boîtier : Macrolon®
IP66
Affichage : Par écran LCD
Signal de commande : 4 - 20 mA
Air comprimé conforme ISO 8573-1 CLASSE 2
Comprend arcade inox pour montage sur vérin, entraineur pour vérin, vis, rondelle

Type: Electro-pneumatic for double acting actuator
Service temperature: -30°C/+80°C
Air supply: 1.4 up to 7 bar
Body: Macrolon®
IP66
Display: LCD screen
Input signal: 4-20 mA
Air supply according to ISO 8573-1 CLASS 2
Includes stainless steel arch for mounting on the actuator, bolts

DN		POSSIE-DE	POSSIE-DE + POSSIE-RECOPIE 4-20MA	POSSIE-DE + POSSIE-FDC	POSSIE-DE + POSSIE-RECOPIE 4-20MA + POSSIE-FDC
mm	inch	Ref.	Ref.	Ref.	Ref.
32-150	1"1/4 - 5"	300180072	300180073	300200074	300200078
		Ex 300180074	Ex 300180075	Ex 300200076	Ex 300200080
200-900	8" - 36"	300180302	300180303	300200075	300200079
		Ex 300180304	Ex 300180305	Ex 300200077	Ex 300200081

RECOPIE : Information du positionnement sur un tableau / Information about positioning information on a board
FDC : Fin de course qui permet d'indiquer la position / Limit switch indicates the position

Ex Zone ATEX | ATEX zone : II 2G Ex ia IIC T6/T4 Gb
II 3G Ex ic IIC T6/T4 Gc

Autres types de protections sur demande | Other protection zone on request

Simple effet | Single-acting

ELECTROPOSITIONNEUR POUR VERIN SIMPLE EFFET | ELECTROPOSITIONER FOR SINGLE-ACTING ACTUATOR

Electropositionneur numérique modèle SIEMENS SIPART - PS2 pour vérin simple effet type TSR
SIEMENS electropositioner type SIPART - PS2 for single-acting TSR actuator type



Type : Electro-pneumatique pour vérin simple effet type TSR
Température de fonctionnement : -30°C/+80°C
Pression d'alimentation : 1,4 à 7 bar
Boîtier : Macrolon®
IP66
Affichage : Par écran LCD
Signal de commande : 4 - 20 mA
Air comprimé conforme ISO 8573-1 CLASSE 2
Comprend arcade inox pour montage sur vérin, entraîneur pour vérin, vis, rondelle

Type: Electro-pneumatic for single-acting actuator TSR type
Service temperature: -30°C/+80°C
Air supply: 1.4 up to 7 bar
Body: Macrolon®
IP66
Display: LCD screen
Input signal: 4-20 mA
Air supply according to ISO 8573-1 CLASS 2
Includes Stainless steel arch for mounting on the actuator, bolts

DN		POSSIE-SE	POSSIE-SE + POSSIE-RECOPIE 4-20MA	POSSIE-SE + POSSIE-FDC	POSSIE-SE + POSSIE-RECOPIE 4-20MA + POSSIE-FDC
mm	inch	Ref.	Ref.	Ref.	Ref.
32-100	1"1/4 - 4"	300200058	300200062	300200066	300200070
		300200060	300200064	300200068	300200072
125-900	5"-36"	300200059	300200063	300200067	300200071
		300200061	300200065	300200069	300200073

RECOPIE : Renseignement de l'information du positionnement sur un tableau / Information about positioning information on a board
FDC : Fin de course qui permet d'indiquer visuellement la position / Limit switch visually indicates the position



Zone ATEX | ATEX zone : II 2G Ex ia IIC T6/T4 Gb
II 3G Ex ic IIC T6/T4 Gc

Autres types de protections sur demande | Other protection zone on request



Montage type : KIT POSSIE-DE sur vérin pour VPI DN40-150 (vérins TDA052 à TDA105)
KIT: POSSIE-DE on actuator for VPI DN40-150 (actuators TDA052 to TDA105)

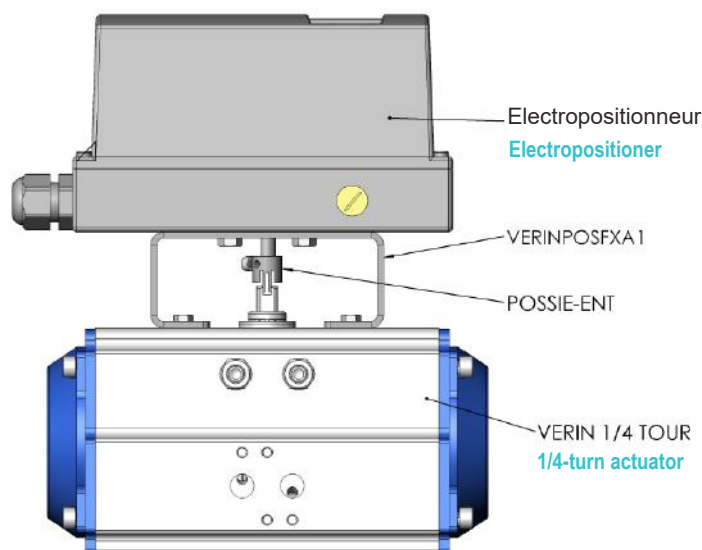

TECWAT

VP ARBRE HUMIDE I WET SHAFT BV DN 80-2000 - PN10/16/25/40



La vanne papillon TECOFI double excentration à brides est particulièrement adaptée pour les stations de pompage et d'irrigation ou réseaux d'adduction d'eau. Elle peut aussi être utilisée pour des applications avec eau de mer ou pour l'industrie. Elle résiste à de fortes pressions et à une température maximale de 80°. Elle peut être à carré, contrôlée par réducteur manuel avec indicateur de position, actionneur pneumatique ou électrique. Conçue suivant la norme EN 593, et testée selon les standards internationaux, la TECWAT est conforme aux certifications EN 1074, WRAS et ACS.

This TECOFI double eccentric butterfly valve, long pattern, with flange connection is ideal for water supply and water pipelines. It can be used with potable water, sea water or industrial application at a max T° of 80°C. Available with conical square, manual gearbox, pneumatic or electric actuator. Design according to EN 593, test procedures established according to international standards, the TECWAT is EN 1074, WRAS and ACS certified.



Version arbre sec IP67 page 69
Dry shaft version IP67 page 69

ANNEAUX DE LEVAGE

Lifting rings

JOINT EPDM

EPDM seal

PEINTURE REVÊTUE

ÉPOXY
250 MICRONS
Epoxy painting,
thickness 250µm

SIÈGE INOX

Étanchéité bi-directionnelle
Modèle double excentration
Montage à sens préférentiel
Stainless steel seat
Bidirectional tightness
Double eccentric type
Assembly with preferred direction

CORPS ET PAPILLON FONTE DUCTILE EN-GJS-500-7

(autres constructions sur demande)

Ductile iron EN-GJS-500-7 body and disc (other material on request)

RÉDUCTEUR MOTORISABLE (IP65 EN STANDARD)

AVEC PLATINE ISO

Worm gear with ISO
mounting plate for electric
actuator



PIEDS D'ASSISE

Heel support

EN OPTION Option

- ✓ IP68
- ✓ Capteur fin de course
- ✓ A carré
- ✓ IP68
- ✓ Limit switch box
- ✓ Conical square

✓ Type à double excentration minimisant l'usure du papillon, prolonge la durabilité et réduit les couples de manoeuvre.

✓ Conception du disque étudiée pour éviter l'usure et les vibrations.

✓ Joint de siège inarrachable et resserrable

✓ Gamme complète du DN80 au 2000 PN10-16-25-40 et en stock jusqu'au DN1200 selon les versions. (ASA150 - ASA300 sur demande).

✓ The double eccentric type design extends the durability and reduces operating torque.

✓ The disc design prevents wear and vibrations.

✓ Untearable seat gasket.

✓ Complete range DN100 up to DN2000 PN10-16-25-40, in stock up to DN1200 depending on the model. (ASA150 - ASA300 on request).

ATTENTION : La gamme des TECWAT ARBRE HUMIDE **PN10 - PN16** va être progressivement remplacée par notre offre TECWAT ARBRE SEC IP67 (p.69)

EVOLUTION :

The TECWAT **PN10 - PN16** range is being replaced by our new TECWAT DRY SHAFT IP67 range (p.69)



**VANNE À PAPILLON DOUBLE EXCENTRATION
DOUBLE ECCENTRIC BUTTERFLY VALVE**



Arbre humide | Wet shaft

VP4201 | VP4241 | VP4251 | VP4261-08EP

Vanne à papillon à double excentration arbre humide type TECWAT à réducteur
Double eccentric wet shaft type butterfly valve TECWAT with gear box



Corps : Fonte ductile EN-GJS-500-7 (GGG50) Epoxy
Papillon : Fonte ductile EN-GJS-500-7 (GGG50) Epoxy
Etanchéité : Inox / EPDM
Raccordement : À brides
Température de service max : +80°C
Manoeuvre : Réducteur à volant avec platine de motorisation ISO
Ecartement long
Etanchéité bi-directionnelle avec un sens de montage préférentiel
Conception suivant la norme EN 593

Body: Ductile iron EN-GJS-500-7 (GGG50) Epoxy coated
Disc: Ductile iron EN-GJS-500-7 (GGG50) Epoxy coated
Seat: Stainless steel / EPDM
Connection: Flanged
Maximum Working temperature: +80°C
Operation: Gearbox with handwheel and ISO top flange for electric actuator connection
Long pattern
Bi-directional sealing with a preferred mounting direction
Design according to EN 593

ACS

PN10/16 - DN<1000 : **EN 1074**



**Papillon inox sur demande
Stainless steel disc on request**



**Certifiée ACS
ACS certified**

**JUSQU'À ÉPUISEMENT DES STOCKS (VOIR P.70)
WHILE STOCKS LAST (SEE ON PAGE 70)**

DN			PN10		PN16		PN25		PN40	
mm	inch	L (mm)	Ref.	Kg	Ref.	Kg	Ref.	Kg	Ref.	Kg
80	3"	-	-	-	VP4241-08EP0080	20	-	-	-	-
100	4"	190	-	-	VP4241-08EP0100	23	-	-	-	-
125	5"	200	-	-	VP4241-08EP0125	28	-	-	-	-
150	6"	210	-	-	*VP4241-08EP0150	31	VP4251-08EP0150	56	-	-
200	8"	230	VP4201-08EP0200	50	VP4241-08EP0200	52	VP4251-08EP0200	80	VP4261-08EP0200	90
250	10"	250	VP4201-08EP0250	62	VP4241-08EP0250	90	VP4251-08EP0250	104	VP4261-08EP0250	158
300	12"	270	*VP4201-08EP0300	94	VP4241-08EP0300	101	VP4251-08EP0300	180	VP4261-08EP0300	265
350	14"	290	VP4201-08EP0350	114	VP4241-08EP0350	153	VP4251-08EP0350	208	VP4261-08EP0350	335
400	16"	310	*VP4201-08EP0400	162	*VP4241-08EP0400	178	VP4251-08EP0400	294	VP4261-08EP0400	405
450	18"	330	VP4201-08EP0450	189	VP4241-08EP0450	245	VP4251-08EP0450	361	VP4261-08EP0450	537
500	20"	350	VP4201-08EP0500	238	*VP4241-08EP0500	316	VP4251-08EP0500	416	VP4261-08EP0500	777
600	24"	390	VP4201-08EP0600	344	VP4241-08EP0600	442	VP4251-08EP0600	618	VP4261-08EP0600	1069
700	28"	430	*VP4201-08EP0700	470	VP4241-08EP0700	613	VP4251-08EP0700	938	VP4261-08EP0700	1650
800	32"	470	*VP4201-08EP0800	662	VP4241-08EP0800	808	VP4251-08EP0800	1192	VP4261-08EP0800	2070
900	36"	510	VP4201-08EP0900	835	VP4241-08EP0900	1130	VP4251-08EP0900	1492	VP4261-08EP0900	3020
1000	40"	550	VP4201-08EP1000	1172	VP4241-08EP1000	1404	VP4251-08EP1000	2111	VP4261-08EP1000	3705
1100	44"	590	VP4201-08EP1100	1852	VP4241-08EP1100	2229	VP4251-08EP1100	2320	VP4261-08EP1100	3482
1200	48"	630	VP4201-08EP1200	1714	VP4241-08EP1200	2308	VP4251-08EP1200	3046	VP4261-08EP1200	5790
1400	56"	710	VP4201-08EP1400	2570	VP4241-08EP1400	3735	VP4251-08EP1400	4808	VP4261-08EP1400	6182
1500	60"	750	VP4201-08EP1500	3140	VP4241-08EP1500	3389	VP4251-08EP1500	4648	VP4261-08EP1500	6958
1600	64"	790	VP4201-08EP1600	3441	VP4241-08EP1600	4459	VP4251-08EP1600	6727	VP4261-08EP1600	8300
1800	72"	870	VP4201-08EP1800	4869	VP4241-08EP1800	6207	VP4251-08EP1800	7884	VP4261-08EP1800	11020
2000	80"	950	VP4201-08EP2000	6516	VP4241-08EP2000	8338	VP4251-08EP2000	11340	VP4261-08EP2000	19400

* Plus disponible en stock / No longer available

EN OPTION | OPTION

**Réducteur motorisable fermeture sens anti-horaire, voir page 75
Motorized gearbox counterclockwise closing, see page 75**

**Adaptateur carré conique sur axe réducteur, voir page 75
Conical square coupling for stem, see on page 75**





VP4201 | VP4241 | VP4251 | VP4261-U04EP

TECWAT AUMA

Arbre humide | Wet shaft

Vanne à papillon à double excentration type TECWAT avec motorisation AUMA 400V/50Hz on/off
Double eccentric butterfly valve TECWAT with AUMA electric actuator 3-phase 400V/50Hz

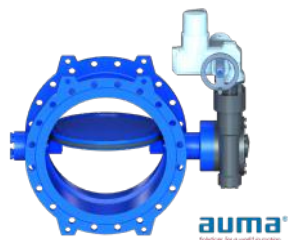

Moteur équipé de :
- 2 contacts fin de course
- 1 résistance de chauffe
- 2 limiteurs de couple
Commande manuelle de secours
Indicateur visuel de position
Protection IP68

Actuator equipped with:
- 2 limit switches
- 1 heat resistor
- 2 torque limiters included
Emergency handwheel
Visual position indicator
IP68 protection

ACS

PN10/16 - DN<1000 :



Papillon inox sur demande
Stainless steel disc on request



Certifiée ACS
ACS certified

JUSQU'À ÉPUISEMENT DES STOCKS
WHILE STOCKS LAST

DN			PN10		PN16		PN25		PN40	
mm	inch	L (mm)	Ref.	Kg	Ref.	Kg	Ref.	Kg	Ref.	Kg
100	4"	190	-	-	VP4241-U04EP0100	42	-	-	-	-
150	6"	210	-	-	VP4241-U04EP0150	50	VP4251-U04EP0150	76	-	-
200	8"	230	VP4201-U04EP0200	71	VP4241-U04EP0200	73	VP4251-U04EP0200	100	VP4261-U04EP0200	133
250	10"	250	VP4201-U04EP0250	82	VP4241-U04EP0250	110	VP4251-U04EP0250	147	VP4261-U04EP0250	201
300	12"	270	VP4201-U04EP0300	114	VP4241-U04EP0300	137	VP4251-U04EP0300	223	VP4261-U04EP0300	285
350	14"	290	VP4201-U04EP0350	157	VP4241-U04EP0350	196	VP4251-U04EP0350	228	VP4261-U04EP0350	378
400	16"	310	VP4201-U04EP0400	205	VP4241-U04EP0400	221	VP4251-U04EP0400	337	VP4261-U04EP0400	448
450	18"	330	VP4201-U04EP0450	232	VP4241-U04EP0450	265	VP4251-U04EP0450	404	VP4261-U04EP0450	580
500	20"	350	VP4201-U04EP0500	258	VP4241-U04EP0500	359	VP4251-U04EP0500	459	VP4261-U04EP0500	820
600	24"	390	VP4201-U04EP0600	387	VP4241-U04EP0600	485	VP4251-U04EP0600	661	VP4261-U04EP0600	1112
700	28"	430	VP4201-U04EP0700	513	VP4241-U04EP0700	656	VP4251-U04EP0700	981	VP4261-U04EP0700	1693
800	32"	470	VP4201-U04EP0800	705	VP4241-U04EP0800	856	VP4251-U04EP0800	1235	VP4261-U04EP0800	2113
900	36"	510	VP4201-U04EP0900	877	VP4241-U04EP0900	1173	VP4251-U04EP0900	1535	VP4261-U04EP0900	3063
1000	40"	550	VP4201-U04EP1000	1255	VP4241-U04EP1000	1447	VP4251-U04EP1000	2154	VP4261-U04EP1000	3748
1100	44"	590	VP4201-U04EP1100	1895	VP4241-U04EP1100	2272	-	-	-	-
1200	48"	630	VP4201-U04EP1200	1797	VP4241-U04EP1200	2351	VP4251-U04EP1200	3089	VP4261-U04EP1200	3950
1400	56"	710	VP4201-U04EP1400	2613	VP4241-U04EP1400	3778	VP4251-U04EP1400	4856	VP4261-U04EP1400	6230
1500	60"	750	VP4201-U04EP1500	3183	VP4241-U04EP1500	3432	VP4251-U04EP1500	4990	VP4261-U04EP1500	7011
1600	64"	790	VP4201-U04EP1600	3484	VP4241-U04EP1600	4507	VP4251-U04EP1600	6775	VP4261-U04EP1600	8353
1800	72"	870	VP4201-U04EP1800	4912	VP4241-U04EP1800	6255	VP4251-U04EP1800	7937	VP4261-U04EP1800	11073
2000	80"	950	VP4201-U04EP2000	6559	VP4241-U04EP2000	8386	VP4251-U04EP2000	11393	VP4261-U04EP2000	19483

Motorisation monophasée pour modèle TECWAT sur demande
Monophase actuator for TECWAT model on request



Kit de motorisation seul page 72
Motorization kit on page 72



Arbre humide | Wet shaft

VP4201 | VP4241 | VP4251 | VP4261-B04EP

TECWAT BERNARD CONTROLS

Vanne à papillon à double excentration type TECWAT avec motorisation BERNARD CONTROLS 400V/50Hz on/off
Double eccentric butterfly valve TECWAT with BERNARD CONTROLS electric actuator 3-phase 400V/50Hz

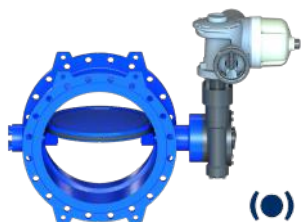

Moteur équipé de :

- 4 contacts fin de course
- 1 résistance de chauffe
- 2 limiteurs de couple

Commande manuelle de secours

Indicateur visuel de position

Protection IP68



PN10/16 - DN<1000 :



Actuator equipped with:

- 4 limit switches
- 1 heat resistor
- 2 torque limiters switches

Emergency handwheel

Visual position indicator

IP68 protection

ACS



Papillon inox sur demande
Stainless steel disc on request



Certifiée ACS
ACS certified

JUSQU'À ÉPUISEMENT DES STOCKS
WHILE STOCKS LAST

DN			PN10		PN16		PN25		PN40	
mm	inch	L (mm)	Ref.	Kg	Ref.	Kg	Ref.	Kg	Ref.	Kg
100	4"	190	-	-	VP4241-B04EP0100	48	-	-	-	-
150	6"	210	-	-	VP4241-B04EP0150	56	VP4251-B04EP0150	81	-	-
200	8"	230	VP4201-B04EP0200	75	VP4241-B04EP0200	77	VP4251-B04EP0200	128	VP4261-B04EP0200	138
250	10"	250	VP4201-B04EP0250	110	VP4241-B04EP0250	138	VP4251-B04EP0250	152	VP4261-B04EP0250	206
300	12"	270	VP4201-B04EP0300	142	VP4241-B04EP0300	149	VP4251-B04EP0300	228	VP4261-B04EP0300	313
350	14"	290	VP4201-B04EP0350	162	VP4241-B04EP0350	201	VP4251-B04EP0350	256	VP4261-B04EP0350	383
400	16"	310	VP4201-B04EP0400	210	VP4241-B04EP0400	226	VP4251-B04EP0400	342	VP4261-B04EP0400	453
450	18"	330	VP4201-B04EP0450	237	VP4241-B04EP0450	293	VP4251-B04EP0450	409	VP4261-B04EP0450	585
500	20"	350	VP4201-B04EP0500	263	VP4241-B04EP0500	364	VP4251-B04EP0500	464	VP4261-B04EP0500	825
600	24"	390	VP4201-B04EP0600	392	VP4241-B04EP0600	490	VP4251-B04EP0600	666	VP4261-B04EP0600	1117
700	28"	430	VP4201-B04EP0700	518	VP4241-B04EP0700	661	VP4251-B04EP0700	986	VP4261-B04EP0700	1698
800	32"	470	VP4201-B04EP0800	710	VP4241-B04EP0800	872	VP4251-B04EP0800	1240	VP4261-B04EP0800	2118
900	36"	510	VP4201-B04EP0900	882	VP4241-B04EP0900	1178	VP4251-B04EP0900	1540	VP4261-B04EP0900	3068
1000	40"	550	VP4201-B04EP1000	1220	VP4241-B04EP1000	1452	VP4251-B04EP1000	2159	VP4261-B04EP1000	3753
1100	44"	590	VP4201-B04EP1100	1900	VP4241-B04EP1100	2277	-	-	-	-
1200	48"	630	VP4201-B04EP1200	1762	VP4241-B04EP1200	2356	VP4251-B04EP1200	3094	VP4261-B04EP1200	5854
1400	56"	710	VP4201-B04EP1400	2618	VP4241-B04EP1400	3783	VP4251-B04EP1400	4872	VP4261-B04EP1400	6246
1500	60"	750	VP4201-B04EP1500	3188	VP4241-B04EP1500	3437	VP4251-B04EP1500	4712	VP4261-B04EP1500	7024
1600	64"	790	VP4201-B04EP1600	3489	VP4241-B04EP1600	4507	VP4251-B04EP1600	6791	VP4261-B04EP1600	8366
1800	72"	870	VP4201-B04EP1800	4917	VP4241-B04EP1800	6271	VP4251-B04EP1800	7950	VP4261-B04EP1800	11086
2000	80"	950	VP4201-B04EP2000	6580	VP4241-B04EP2000	8404	VP4251-B04EP2000	11406	VP4261-B04EP2000	19466

Motorisation monophasée pour modèle TECWAT sur demande
Monophase actuator for TECWAT model on request



Kit de motorisation seul page 73
Motorization kit on page 73



TECWAT

VP ARBRE SEC I DRY SHAFT BV DN 80-1600 - PN10/16



Grande résistance à la corrosion High resistance to corrosion



- ✓ 100% étanche : arbre chemisé limitant l'usure des axes
- ✓ Réducteur avec platine IP67 avec indicateur de position en standard
- ✓ Sans entretien grâce aux paliers auto-lubrifiés
- ✓ Résistant à la corrosion :
 - Boulonnerie acier inoxydable 304
 - Revêtement par poudre époxy 250µm cuite au four
- ✓ Indice de protection du réducteur IP67
- ✓ Papillon à double excentration
- ✓ Arbre Inox 420 et siège Inox 304
- ✓ Embase normalisée ISO 5210 permettant le montage d'actionneurs électriques
- ✓ Conforme aux agréments WRAS/ACS pour eau potable / EN1074

- ✓ 100% watertight: sleeved shaft limits wear on the axes.
- ✓ IP67 mechanical gearbox and position indicator as standard
- ✓ Self-lubricated bearings : maintenance free
- ✓ High resistance to corrosion:
 - Retaining ring bolts in Stainless Steel 304
 - Oven-baked epoxy powder coating 250µm
- ✓ Gearbox protection class IP67
- ✓ Double eccentric disc
- ✓ ISO 5210 standardized upper flange for electric actuators installation
- ✓ Conform to WRAS/ ACS potable water certifications / EN1074



Étanchéité Bi-directionnelle

- ✓ L'axe sans jeu est relié au papillon. Il n'est jamais en contact avec le fluide, ce qui le protège de la corrosion.
- ✓ Siège d'étanchéité encastré et maintenu en place par la frette en inox et resserrable (durée de vie).
- ✓ Couple de manœuvre réduit.
- ✓ Faible perte de charge.
- ✓ Réducteur IP67.

Bi-directional sealing

- ✓ The backlash-free shaft is connected to the disc. It is never in contact with the fluid, protecting it from corrosion.
- ✓ Built-in watertight seat held in place by Stainless steel retaining ring.
- ✓ Reduced operating torque.
- ✓ Low pressure drop.
- ✓ IP67 manual gearbox with handwheel.

CORPS ET PAPILLON FONTE DUCTILE EN-GJS-500-7 (GGG50) *

Ductile iron EN-GJS-500-7* body and disc (GGG50)

ANNEAUX DE LEVAGE

Lifting eyes

ARBRE SEC INOX 420

Stainless steel 420 dry shaft

PALIER ALUMINIUM BRONZE

Aluminium bronze bearing

RÉDUCTEUR À VOLANT AVEC PLATINE DE MOTORISATION IP67

Manual gearbox IP67 with ISO top flange for actuator connection

JOINT DE SIÈGE EPDM

Resserrable (changement sans démontage papillon)
EPDM seat gasket
Retightenable (can be changed without dismantling the disc)

PIEDS D'ASSISE

Support foot

EN 1074

WRAS APPROVED PRODUCT

ACS

SIÈGE INOX 304

Stainless steel 304 seat

* Autres nuances sur demande
Other material on request



VANNE À PAPILLON DOUBLE EXCENTRATION - ARBRE SEC DOUBLE ECCENTRIC BUTTERFLY VALVE - DRY SHAFT



Arbre sec | Dry shaft

VP4208-08EP | VP4248-08EP

Vanne à papillon à double excentration type TECWAT arbre sec - Réducteur IP67
Double eccentric butterfly valve TECWAT - dry shaft - IP67 gearbox



Corps : Fonte ductile EN-GJS-500-7 (GGG50)
Papillon : Fonte ductile EN-GJS-500-7 (GGG50)
Etanchéité : EPDM
Raccordement : À brides
Température de service max : +80°C
Manoeuvre : Réducteur à volant avec platine de motorisation ISO
Platine de motorisation ISO (IP67)

EN 1074



ACS

DN<1000

Arbre sec
Dry shaft

Body: Ductile iron EN-GJS-500-7 (GGG50)
Disc: Ductile iron EN-GJS-500-7 (GGG50)
Seat: EPDM
Connection: Flanged
Maximum Working temperature: +80°C
Operation:
IP67 manual gearbox with handwheel
ISO top flange for electric actuator connection



EN OPTION | OPTION

Réducteur motorisable fermeture sens anti-horaire p.75
Motorized gearbox counterclockwise closing p.75

NEW

DN			PN10		PN16	
mm	inch	L (mm)	Ref.	Kg	Ref.	Kg
80	3"	180	voir / see PN16		VP4248-08EP0080	17
100	4"	190			VP4248-08EP0100	23
125	5"	200			VP4248-08EP0125	28
150	6"	210			VP4248-08EP0150	31
200	8"	230	VP4208-08EP0200	50	VP4248-08EP0200	52
250	10"	250	VP4208-08EP0250	62	VP4248-08EP0250	90
300	12"	270	VP4208-08EP0300	94	VP4248-08EP0300	103
350	14"	290	VP4208-08EP0350	114	VP4248-08EP0350	153
400	16"	310	VP4208-08EP0400	162	VP4248-08EP0400	178
450	18"	330	VP4208-08EP0450	189	VP4248-08EP0450	245
500	20"	350	VP4208-08EP0500	238	VP4248-08EP0500	316
600	24"	390	VP4208-08EP0600	344	VP4248-08EP0600	442
700	28"	430	VP4208-08EP0700	470	VP4248-08EP0700	613
800	32"	470	VP4208-08EP0800	662	VP4248-08EP0800	808
900	36"	510	VP4208-08EP0900	835	VP4248-08EP0900	1130
1000	40"	550	VP4208-08EP1000	1172	VP4248-08EP1000	1404
1100	44"	590	VP4208-08EP1100	1852	VP4248-08EP1100	2229
1200	48"	630	VP4208-08EP1200	1714	VP4248-08EP1200	2308
1400	56"	710	VP4208-08EP1400	2570	VP4248-08EP1400	3735
1500	60"	750	VP4208-08EP1500	3140	VP4248-08EP1500	3389
1600	64"	790	VP4208-08EP1600	3441	VP4248-08EP1600	4459

VP4208-051EP | VP4248-51EP

Vanne à papillon à double excentration type TECWAT arbre sec - À carré
Double eccentric butterfly valve TECWAT - dry shaft - with square

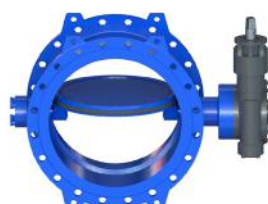

Corps : Fonte ductile EN-GJS-500-7 (GGG50)
Papillon : Fonte ductile EN-GJS-500-7 (GGG50)
Etanchéité : EPDM
Raccordement : À brides
Température de service max : +80°C
Manoeuvre : A carré de manoeuvre

EN 1074



ACS

DN<1000

Arbre sec
Dry shaft

Retrouvez le carré seul en page 75.

Body: Ductile iron EN-GJS-500-7 (GGG50)
Disc: Ductile iron EN-GJS-500-7 (GGG50)
Seat: EPDM
Connection: Flanged
Maximum Working temperature: +80°C
Operation: With square

Find the conical square on page 75.

EN OPTION | OPTION

Adaptateur carré conique sur axe réducteur seul p.75
Conical square coupling for stem p.75

NEW

DN			PN10		PN16	
mm	inch	L (mm)	Ref.	Kg	Ref.	Kg
80	3"	180	voir / see PN16		VP4248-051EP0080	17
100	4"	190			VP4248-051EP0100	23
125	5"	200			VP4248-051EP0125	28
150	6"	210			VP4248-051EP0150	31
200	8"	230	VP4208-051EP0200	50	VP4248-051EP0200	52
250	10"	250	VP4208-051EP0250	62	VP4248-051EP0250	90
300	12"	270	VP4208-051EP0300	94	VP4248-051EP0300	103
350	14"	290	VP4208-051EP0350	114	VP4248-051EP0350	153
400	16"	310	VP4208-051EP0400	162	VP4248-051EP0400	178
450	18"	330	VP4208-051EP0450	189	VP4248-051EP0450	245
500	20"	350	VP4208-051EP0500	238	VP4248-051EP0500	316
600	24"	390	VP4208-051EP0600	344	VP4248-051EP0600	442
700	28"	430	VP4208-051EP0700	470	VP4248-051EP0700	613
800	32"	470	VP4208-051EP0800	662	VP4248-051EP0800	808
900	36"	510	VP4208-051EP0900	835	VP4248-051EP0900	1130
1000	40"	550	VP4208-051EP1000	1172	VP4248-051EP1000	1404
1100	44"	590	VP4208-051EP1100	1852	VP4248-051EP1100	2229
1200	48"	630	VP4208-051EP1200	1714	VP4248-051EP1200	2308
1400	56"	710	VP4208-051EP1400	2570	VP4248-051EP1400	3735
1500	60"	750	VP4208-051EP1500	3140	VP4248-051EP1500	3389
1600	64"	790	VP4208-051EP1600	3441	VP4248-051EP1600	4459





Arbre sec | Dry shaft

VP4208 | VP4248-U04EP

TECWAT AUMA

Vanne à papillon à double excentration type TECWAT arbre sec avec motorisation AUMA 400V/50Hz on/off
Double eccentric type butterfly valve TECWAT dry shaft with AUMA electric actuator 3-phase 400V/50Hz

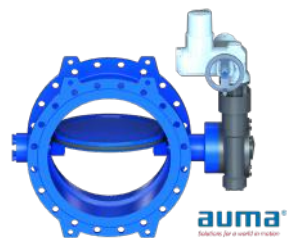

Moteur équipé de :
- 2 contacts fin de course
- 1 résistance de chauffe
- 2 limiteurs de couple
Commande manuelle de secours
Indicateur visuel de position
Protection IP68



Actuator equipped with:
- 2 limit switches
- 1 heat resistor
- 2 torque limiters included
Emergency handwheel
Visual position indicator
IP68 protection



DN<1000

Arbre sec
Dry shaft



Kit de motorisation seul page 72
Motorization kit on page 72

DN			PN10		PN16	
mm	inch	L (mm)	Ref.	Kg	Ref.	Kg
100	4"	190	voir / see PN16		VP4248-U04EP0100	42
125	5"	200			VP4248-U04EP0125	45
150	6"	210			VP4248-U04EP0150	50
200	8"	230	VP4208-U04EP0200	69	VP4248-U04EP0200	72
250	10"	250	VP4208-U04EP0250	82	VP4248-U04EP0250	110
300	12"	270	VP4208-U04EP0300	114	VP4248-U04EP0300	146
350	14"	290	VP4208-U04EP0350	157	VP4248-U04EP0350	196
400	16"	310	VP4208-U04EP0400	205	VP4248-U04EP0400	221
450	18"	330	VP4208-U04EP0450	232	VP4248-U04EP0450	265
500	20"	350	VP4208-U04EP0500	258	VP4248-U04EP0500	359
600	24"	390	VP4208-U04EP0600	387	VP4248-U04EP0600	485
700	28"	430	VP4208-U04EP0700	513	VP4248-U04EP0700	656
800	32"	470	VP4208-U04EP0800	705	VP4248-U04EP0800	856
900	36"	510	VP4208-U04EP0900	878	VP4248-U04EP0900	1173
1000	40"	550	VP4208-U04EP1000	1255	VP4248-U04EP1000	1447
1100	44"	590	VP4208-U04EP1100	1852	VP4248-U04EP1100	2272
1200	48"	630	VP4208-U04EP1200	1797	VP4248-U04EP1200	2351
1400	56"	710	VP4208-U04EP1400	2613	VP4248-U04EP1400	3778
1500	60"	750	VP4208-U04EP1500	3183	VP4248-U04EP1500	3432
1600	64"	790	VP4208-U04EP1600	3484	VP4248-U04EP1600	4507

VP4208 | VP4248-B04EP

TECWAT BERNARD CONTROLS

Vanne à papillon à double excentration type TECWAT arbre sec avec motorisation BERNARD CONTROLS 400V/50Hz on/off
Double eccentric type butterfly valve TECWAT dry shaft with BERNARD CONTROLS electric actuator 3-phase 400V/50Hz

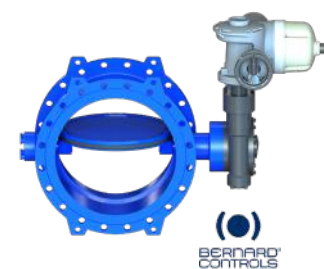

Moteur équipé de :
- 2 contacts fin de course
- 1 résistance de chauffe
- 2 limiteurs de couple inclus
Commande manuelle de secours
Indicateur visuel de position
Protection IP68



Actuator equipped with:
- 2 limit switches
- 1 heat resistor
- 2 torque limiters switches included
Emergency handwheel
Visual position indicator
IP68 protection



DN<1000

Arbre sec
Dry shaft



Kit de motorisation seul page 73
Motorization kit on page 73

DN			PN10		PN16	
mm	inch	L (mm)	Ref.	Kg	Ref.	Kg
100	4"	190	voir / see PN16		VP4248-B04EP0100	48
125	5"	200			VP4248-B04EP0125	50
150	6"	210			VP4248-B04EP0150	56
200	8"	230	VP4208-B04EP0200	75	VP4248-B04EP0200	77
250	10"	250	VP4208-B04EP0250	110	VP4248-B04EP0250	138
300	12"	270	VP4208-B04EP0300	142	VP4248-B04EP0300	151
350	14"	290	VP4208-B04EP0350	162	VP4248-B04EP0350	201
400	16"	310	VP4208-B04EP0400	210	VP4248-B04EP0400	226
450	18"	330	VP4208-B04EP0450	237	VP4248-B04EP0450	293
500	20"	350	VP4208-B04EP0500	263	VP4248-B04EP0500	364
600	24"	390	VP4208-B04EP0600	392	VP4248-B04EP0600	490
700	28"	430	VP4208-B04EP0700	518	VP4248-B04EP0700	661
800	32"	470	VP4208-B04EP0800	710	VP4248-B04EP0800	872
900	36"	510	VP4208-B04EP0900	883	VP4248-B04EP0900	1178
1000	40"	550	VP4208-B04EP1000	1220	VP4248-B04EP1000	1452
1100	44"	590	VP4208-B04EP1100	1900	VP4248-B04EP1100	2277
1200	48"	630	VP4208-B04EP1200	1762	VP4248-B04EP1200	2356
1400	56"	710	VP4208-B04EP1400	2618	VP4248-B04EP1400	3783
1500	60"	750	VP4208-B04EP1500	-	VP4248-B04EP1500	-
1600	64"	790	VP4208-B04EP1600	3489	VP4248-B04EP1600	4507



MOTORISATION POUR VANNES À PAPILLON TECWAT
ACTUATOR FOR TECWAT BUTTERFLY VALVES



Arbre humide
Wet shaft



Arbre sec
Dry shaft



ASA
150



Solutions for a world in motion



Caractéristiques moteur AUMA
SA07.2 à SA16.2

- Plage de couple entre 10Nm et 1 000 Nm.
- Vitesse de sortie entre 4 et 180 tr/min.
- Enregistrement de la course et du couple.
- Protection anti-corrosion de grande qualité (revêtement poudre 2 couches 140microns, selon EN ISO 12944-2, ou DIN 55633).
- Classe d'isolation standard F : tropicalisé.
- Montage dans toutes les positions.
- Indice de protection élevé IP68 (préconisation pour une protection maximale : presse-étoupe métallique + câble IP68).
- C5M (certificat ISO 12944-2) (option sur demande).
- ATEX sur demande.
- Bornier avec connecteur débrochable.
- Indicateur visuel de position.

Main features: AUMA actuator
SA07.2 to SA16.2

- Torque range from 10Nm to 1000Nm.
- Output speeds from 4 to 180 rpm.
- High quality corrosion protection: two-layer powder coating 140micron, according to EN ISO 12944-2, or DIN 55633.
- Insulation protection class type F: tropicalized.
- Mounting in all positions.
- High enclosure protection: IP68.
- C5M (ISO 12944-2 certification) (option on request).
- ATEX on request.
- Terminal block with removable connector.
- Visual position indicator.

EN OPTION | OPTION

Entretoise universelle (moteur SA/SQ)
Universal (SA / SQ actuator)



Cette entretoise permet de maintenir l'étanchéité du servomoteur même en cas de défaillance du presse étoupe, du câble éventuellement endommagé ou d'un risque d'immersion.

Sécurité renforcée
Reinforced security

This intermediate frame preserves the enclosure protection even if the electrical connection is removed and prevents ingress of dirt or humidity into the housing.

Ref. : **SA/SQ-ENTRETOISEDS**

U04

AUMA

KIT motorisation Auma 3 phases 400V/50Hz On/Off pour TECWAT

Auma KIT electric actuator 3-phase 400V/50Hz On/Off for TECWAT



Moteur équipé de :

- 2 contacts fin de course
- 1 résistance de chauffe
- 2 limiteurs de couple

Commande manuelle de secours

Indicateur visuel de position

Protection IP68

Actuator equipped with:

- 2 limit switches
- 1 heat resistor
- 2 torque limiters included

Emergency handwheel

Visual position indicator

IP68 protection

*sur demande / on request

DN			PN10		PN16		PN25 / ASA150		PN40	
mm	inch	L (mm)	Ref.	Type	Ref.	Type	Ref.	Type	Ref.	Type
80	3"	-	-	-	300190110	SA07.2	-	-	-	-
100	4"	-	-	-	300200179	SA07.2	-	-	-	-
125	5"	-	-	-	300190109	SA07.2	300190114	SA07.6	-	-
150	6"	-	-	-	-	-	300190113	SA07.6	300190122	SA10.2
200	8"	230	300190107	SA07.2	300190113	SA07.6	300190120	SA10.2	300190117	SA07.6
250	10"	250	300190112	SA07.6	300190118	SA07.6	300190122	SA10.2	300190125	SA10.2
300	12"	270	300190118	SA10.2	300190120	SA10.2	300190116	SA07.6	300190124	SA10.2
350	14"	290	300190120	SA10.2	300190115	SA07.6	300190124	SA10.2	300190125	SA10.2
400	16"	310	300190115	SA07.6	300190123	SA10.2	300190125	SA10.2	300190126	SA10.2
450	18"	330	300190123	SA10.2	300190124	SA10.2	300190124	SA10.2	300190121	SA10.2
500	20"	350	300190125	SA10.2	300190124	SA10.2	300190126	SA10.2	300190119	SA10.2
600	24"	390	300190125	SA10.2	300190133	SA14.2	300190125	SA10.2	300190121	SA10.2
700	28"	430	300190126	SA10.2	300190125	SA10.2	300190119	SA10.2	300190119	SA10.2
800	32"	470	300190126	SA10.2	300190119	SA10.2	300190121	SA10.2	300190121	SA10.2
900	36"	510	300190125	SA10.2	300190119	SA10.2	300190128	SA14.2	300190127	SA14.2
1000	40"	550	300190125	SA10.2	300190126	SA10.2	300190128	SA14.2	300190132	SA14.6
1200	48"	630	300190125	SA10.2	300190119	SA10.2	300190130	SA14.2	300190134	SA14.6
1400	56"	710	300190125	SA10.2	300190128	SA14.2	300190132	SA14.6	300190134	SA14.6
1600	64"	790	300190127	SA14.2	300190130	SA14.2	300190134	SA14.6	300190135	SA16.2
1800	72"	870	300190127	SA14.2	300190134	SA14.2	300190134	SA14.6	300190135	SA16.2
2000	80"	950	300190127	SA14.2	300190134	SA14.2	300190134	SA14.6	300190135	SA16.2



Main features : BERNARD actuator AT3 to AT50

- > Torque range from 12 Nm to 500 Nm.
- > Output speeds from 10 to 1620r turns.
- > Mechanical position indicator.
- > Mounting in all positions.

Caractéristiques moteur BERNARD AT3 à AT50

- > Plage de couple entre 12 Nm et 500 Nm.
- > Vitesse de sortie entre 10 et 1620 tr.
- > Indicateur visuel de position mécanique.
- > Enregistrement de la course et du couple.
- > Montage dans toutes les positions.
- > Indice de protection élevé IP68.
- > Environnement corrosif: testé en C4 selon ISO 12944.
- > Large passage de tige avec un capot facile à installer et étanche.
- > Application mobile pour smartphone (options sur demande auprès du constructeur).

- > High enclosure protection: IP68.
- > Corrosive environment : tested in C4 environment according to ISO 12944.
- > Application for mobile device (options on request from the manufacturer).

B04

BERNARD CONTROLS

Motorisation Bernard Controls 3 phases 400V/50Hz On/Off pour TECWAT

Bernard Controls electric actuator 3-phase 400V/50Hz On/Off for TECWAT

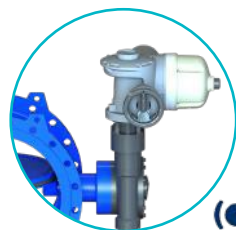

Moteur équipé de :

- 4 contacts fin de course
- 1 résistance de chauffe
- 2 limiteurs de couple

Commande manuelle de secours
Indicateur visuel de position
Protection IP68

Actuator equipped with:

- 4 limit switches
- 1 heat resistor
- 2 torque limiters switches

Emergency handwheel
Visual position indicator
IP68 protection



*sur demande / on request

DN		L (mm)	PN10		PN16		PN25 / ASA150		PN40	
mm	inch		Ref.	Type	Ref.	Type	Ref.	Type	Ref.	Type
80	3"	-	-	-	300200180	AT3	-	-	-	-
100	4"	-	-	-	300190165	AT3	-	-	-	-
125	5"	-	-	-	-	-	-	-	-	-
150	6"	210	-	-	300190164	AT3	300190168	AT6L	300190171	AT6
200	8"	230	300190162	AT3	300190167	AT6L	300190176	AT14	300190176	AT14
250	10"	250	300190170	AT6	300190170	AT6	300190176	AT14	300190177	AT14
300	12"	270					300190177	AT14	300190173	AT6
350	14"	290			300190176	AT14	300190173	AT6	300190181	AT14
400	16"	310	300190176	AT14			300190180	AT14		
450	18"	330			300190172	AT6			300190182	AT14
500	20"	350	300190169	AT6L	300190179	AT14	300190181	AT14	300190181	AT14
600	24"	390	300190178	AT14	300190178	AT14	300190180	AT14	300190174	AT14
700	28"	430			300190179	AT14				
800	32"	470	300190179	AT14	300190185	AT25	300190182	AT14		
900	36"	510	300190178	AT14	300190182	AT14			300190175	AT14
1000	40"	550	300190181	AT14			300190174	AT14		
1200	48"	630			300190174	AT14			300190175	AT14
1400	56"	710	300190182	AT14			300190184	AT25	300190188	AT50
1600	64"	790			300190175	AT14	300190187	AT25	300190190	AT50
1800	72"	870	300190174	AT14	300190187	AT25	300190190	AT50	300190188	AT50
2000	80"	950	300190187	AT25	300190190	AT50	300190188	AT50	300190188	AT50

VANNE À PAPILLON DOUBLE EXCENTRATION - ASA150
DOUBLE ECCENTRIC BUTTERFLY VALVE - ASA150

NEW

ASA
150Arbre humide
Wet shaft

VP4238-08EP

Vanne à papillon à double excentration type tecwat ASA 150 à réducteur
 Double eccentric type butterfly valve TECWAT ASA150 with gearbox



Corps et papillon : Fonte ductile revêtu époxy
 Siège : Acier inoxydable
 Joint de papillon : EPDM
 Raccordement : À brides ASA150
 Pression de service max : 20 bar
 Manœuvre par réducteur manuel avec indicateur d'ouverture.
 Platine ISO 5210 pour adaptation de moteur électrique.

Body and Disc: Ductile iron + epoxy coated
 Seat: Stainless steel
 Sealing: EPDM
 Connection: Flanged ASA150
 Maximum working pressure: 20 bar
 Gearbox with handwheel and visual indicator. ISO 5210 upper flange for electric actuator.

EN OPTION / OPTION

Réducteur motorisable fermeture sens anti-horaire, voir page 75
 Motorized gearbox counterclockwise closing, see page 75

DN		L (mm)	Ref.	Kg
mm	inch			
150	6"	210	VP4238-08EP0150	56
200	8"	230	VP4238-08EP0200	80
250	10"	250	VP4238-08EP0250	104
300	12"	270	VP4238-08EP0300	180
350	14"	290	VP4238-08EP0350	208
400	16"	310	VP4238-08EP0400	294
450	18"	330	VP4238-08EP0450	361
500	20"	350	VP4238-08EP0500	416
600	24"	390	VP4238-08EP0600	618
700	28"	430	VP4238-08EP0700	938
800	32"	470	VP4238-08EP0800	1192
900	36"	510	VP4238-08EP0900	2111
1000	40"	550	VP4238-08EP1000	2320
1200	48"	630	VP4238-08EP1200	3046
1400	56"	710	VP4238-08EP1400	4808

VP4238-U04EP

TECWAT AUMA

Vanne à papillon à double excentration type tecwat ASA 150 avec motorisation AUMA
 Double eccentric type butterfly valve TECWAT ASA150 with AUMA electric actuator

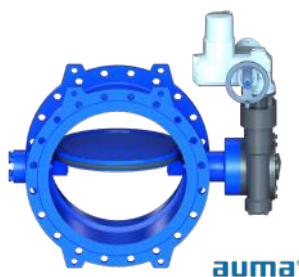

Corps et papillon : Fonte ductile revêtu époxy
 Siège : Acier inoxydable
 Joint de papillon : EPDM
 Raccordement : À brides ASA150

Equipé d'un réducteur avec indicateur d'ouverture et d'un moteur électrique AUMA 400V TRI 50HZ - IP68 - Fonction TOR - 2 contacts fin de course - 2 limiteurs de couple - Résistance chauffante - Commande manuelle de secours.

Body and Disc: Ductile iron + epoxy coated
 Seat: Stainless steel
 Sealing: EPDM
 Connection: Flanged ASA150

Gearbox with visual opening indicator operating by electric actuator AUMA 400V 3phase 50HZ ON/OFF function - Watertight IP68 - 2 limit switches - 2 torque limiters - Heat resistor - Emergency handwheel.

Kit de motorisation seul page 72
 Motorization kit on page 72

DN		L (mm)	Ref.	Kg
mm	inch			
150	6"	210	VP4238-U04EP0150	76
200	8"	230	VP4238-U04EP0200	100
250	10"	250	VP4238-U04EP0250	147
300	12"	270	VP4238-U04EP0300	223
400	16"	310	VP4238-U04EP0400	337
450	18"	330	VP4238-U04EP0450	361
500	20"	350	VP4238-U04EP0500	416
600	24"	390	VP4238-U04EP0600	661
700	28"	430	VP4238-U04EP0700	981
800	32"	470	VP4238-U04EP0800	1235
900	36"	510	VP4238-U04EP0900	2154
1000	40"	550	VP4238-U04EP1000	2363
1200	48"	630	VP4238-U04EP1200	3089
1400	56"	710	VP4238-U04EP1400	4856

VP4238-B04EP

TECWAT BERNARD CONTROLS

Vanne à papillon à double excentration type tecwat ASA 150 avec motorisation BERNARD CONTROLS
 Double eccentric type butterfly valve TECWAT ASA150 with BERNARD CONTROLS electric actuator

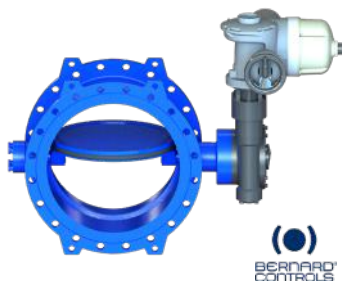

Corps et papillon : Fonte ductile revêtu époxy
 Siège : Acier inoxydable
 Joint de papillon : EPDM
 Raccordement : À brides ASA150

Equipé d'un réducteur avec indicateur d'ouverture et d'un moteur électrique BERNARD 400V TRI 50HZ - IP68 - Fonction TOR - 4 contacts fin de course - 2 limiteurs de couple - Résistance chauffante - Commande manuelle de secours.

Body and Disc: Ductile iron + epoxy coated
 Seat: Stainless steel
 Sealing: EPDM
 Connection: Flanged ASA150

Gearbox with visual opening indicator operating by electric actuator BERNARD 400V 3phase 50HZ ON/OFF function - Watertight IP68 - 4 limit switches - 2 torque limiters - Heat resistor - Emergency handwheel.

Kit de motorisation seul page 73
 Motorization kit on page 73

DN		L (mm)	Ref.	Kg
mm	inch			
150	6"	210	VP4238-B04EP0150	81
200	8"	230	VP4238-B04EP0200	128
250	10"	250	VP4238-B04EP0250	152
300	12"	270	VP4238-B04EP0300	228
350	14"	290	VP4238-B04EP0350	256
400	16"	310	VP4238-B04EP0400	342
450	18"	330	VP4238-B04EP0450	409
500	20"	350	VP4238-B04EP0500	464
600	24"	390	VP4238-B04EP0600	666
700	28"	430	VP4238-B04EP0700	986
800	32"	470	VP4238-B04EP0800	1240
900	36"	510	VP4238-B04EP0900	1540
1000	40"	550	VP4238-B04EP1000	2159
1200	48"	630	VP4238-B04EP1200	3094
1400	56"	710	VP4238-B04EP1400	4872



ACCESSOIRES POUR TECWAT
ACCESSORIES FOR TECWAT



Arbre humide
Wet shaft



Arbre sec
Dry shaft



ASA
150

VPWREDUCTFSAH

Réducteur motorisable fermeture sens anti-horaire pour TECWAT seul
Motorized gearbox counterclockwise closing for TECWAT type valve



Embase suivant norme ISO5211
Indice de protection IP67

Prix à rajouter à la vanne

ISO mounting flange according to ISO5211
IP67 protection

Price to be added to the valve

DN	PN10	PN16	PN25 / ASA150	PN40
	Ref	Ref	Ref	Ref
100	-	VPWREDUCTFSAH0	VPWREDUCTFSAH1	VPWREDUCTFSAH1
150	-	VPWREDUCTFSAH0	VPWREDUCTFSAH1	VPWREDUCTFSAH2
200	VPWREDUCTFSAH1	VPWREDUCTFSAH1	VPWREDUCTFSAH2	VPWREDUCTFSAH2
250	VPWREDUCTFSAH1	VPWREDUCTFSAH2	VPWREDUCTFSAH2	VPWREDUCTFSAH3
300	VPWREDUCTFSAH2	VPWREDUCTFSAH2	VPWREDUCTFSAH3	VPWREDUCTFSAH34
350	VPWREDUCTFSAH2	VPWREDUCTFSAH3	VPWREDUCTFSAH34	VPWREDUCTFSAH44
400	VPWREDUCTFSAH3	VPWREDUCTFSAH3	VPWREDUCTFSAH44	VPWREDUCTFSAH44
450	VPWREDUCTFSAH3	VPWREDUCTFSAH34	VPWREDUCTFSAH44	VPWREDUCTFSAH55
500	VPWREDUCTFSAH34	VPWREDUCTFSAH44	VPWREDUCTFSAH55	VPWREDUCTFSAH55
600	VPWREDUCTFSAH44	VPWREDUCTFSAH44	VPWREDUCTFSAH55	VPWREDUCTFSAH66
700	VPWREDUCTFSAH44	VPWREDUCTFSAH55	VPWREDUCTFSAH66	VPWREDUCTFSAH77
800	VPWREDUCTFSAH55	VPWREDUCTFSAH55	VPWREDUCTFSAH66	VPWREDUCTFSAH77
900	VPWREDUCTFSAH55	VPWREDUCTFSAH66	VPWREDUCTFSAH67	VPWREDUCTFSAH77
1000	VPWREDUCTFSAH66	VPWREDUCTFSAH67	VPWREDUCTFSAH77	VPWREDUCTFSAH88
1100	VPWREDUCTFSAH66	VPWREDUCTFSAH77	-	VPWREDUCTFSAH88
1200	VPWREDUCTFSAH67	VPWREDUCTFSAH77	VPWREDUCTFSAH88	VPWREDUCTFSAH99
1400	VPWREDUCTFSAH77	VPWREDUCTFSAH88	VPWREDUCTFSAH88	VPWREDUCTFSAH99
1500	VPWREDUCTFSAH77	VPWREDUCTFSAH88	VPWREDUCTFSAH88	VPWREDUCTFSAH99
1600	VPWREDUCTFSAH77	VPWREDUCTFSAH88	VPWREDUCTFSAH99	-
1800-2000	VPWREDUCTFSAH88	VPWREDUCTFSAH99	-	-
2200-2400	VPWREDUCTFSAH99	-	-	-

KIT XCKM TELEMECANIQUE SCHNEIDER

Kit contact fin de course mécanique sur réducteur pour TECWAT
Mechanical limit switch kit for Tecwat gearbox for TECWAT type valve

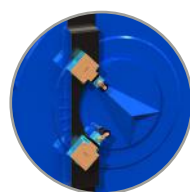

Composé de :
- Plaque support inox 304
XCKM pour réducteur
- Contact fin de course
electromécanique

Comprised of:
- Support plate Stainless steel
304 XCKM for gearbox
- Tappet roller electro-
mechanical limit switch

Ref	PN10		PN16		PN25 / ASA150		PN40	
	mm	inch	mm	inch	mm	inch	mm	inch
300200096	-	-	DN 100 - 150	4"-6"	-	-	-	-
300200098	DN 200 - 250	8"-10"	DN 200	8"	DN 100 - 150	4"-6"	DN 100	4"
300200099	DN 300 - 350	12"-14"	DN 250 - 300	10"-12"	DN 200 - 250	8"-10"	DN 150 - 200	6"-8"
300200100	DN 400 - 500	16"-20"	DN 350 - 450	14"-18"	DN 300 - 350	12"-14"	DN 250 - 300	10"-12"
300200101	DN 600 - 700	24"-28"	DN 500 - 600	20"-24"	DN 400 - 450	16"-18"	DN 350 - 400	14"-16"
300200102	DN 800 - 900	32"-36"	DN 700 - 800	28"-32"	DN 500 - 600	20"-24"	DN 450 - 500	18"-20"
300200103	DN 1000 - 1200	40"-48"	DN 900 - 1000	36"-40"	DN 700 - 900	28"-36"	DN 600	24"
300200104	DN1400 - 1600	56"-64"	DN 1100 - 1200	44"-48"	DN 1000	40"	DN 700 - 900	28"-36"
300200105	DN1800 - 2000	72"-80"	DN 1400 - 1600	56"-64"	DN 1200 - 1500	48"-60"	DN 1000 - 1100	40"-44"
300200106	DN2200 - 2400	88"-96"	DN 1800 - 2000	72"-80"	DN 1600	64"	DN 1200 - 1500	48"-60"

*option version inductif possible, nous contacter / inductive option available on request

CARRE-B3F10 | CARRE-B3F14

Adaptateur carré conique sur axe pour TECWAT
Conical square coupling for stem for TECWAT type



Se positionne en sortie de réducteur pour une manœuvre par clés de fontainier (page 143).
Livré avec une vis de pression.
Can be positioned at the output of the gearbox for operation with fountain key (page 143).
Delivered with thrust screw.



Permet les montages à rallonge
Used for extension model

DN	PN	Ref.
100-1000	10-16-25-40	CARRE-B3F10
1200-1500	10-16-25	CARRE-B3F10
1200-1500	40	CARRE-B3F14
1600-1800	10-16	CARRE-B3F10
1600	25	CARRE-B3F14
2000-2200	10-25	CARRE-B3F14

KIT COLONNETTE DROITE POUR TECWAT

PEDESTAL FLOOR MOUNTING KIT FOR TECWAT BUTTERFLY VALVES

À VOLANT | WITH HANDWHEEL



VOL1VOL2

GUCOL

Plaque de guidage
Support plate

COL3-F10

Colonne
Pedestal

U04 AUMA

Actionneur
Actuator

F10AU1

Platine ISO
ISO Top Flange

COL3-F10

Colonne
Pedestal

EXT1/2/3/4/5

Rallonge / Extension

PAL 2/3

Palier de guidage
Guide plate

VPDOUILLE0136

Entraîneur
Coupling adapter

VANNE PAPILLON TECWAT

Tecwat butterfly valve

Représentation à titre indicatif (contre-brides et tirants non représentés, ils sont obligatoires dans toutes installations).
Representation for reference only (counter flanges and tie rods not shown are required in all installations).

KIT COLONNETTE MURALE POUR TECWAT

PEDESTAL WALL MOUNTING KIT FOR TECWAT BUTTERFLY VALVES

À VOLANT | WITH HANDWHEEL



VOL1/VOL2

COL1

Colonnnette
Pedestal



La distance entre le mur et les colonnettes murales n'est pas réglable. Prévoir un déport avec le mur ou un système pour plaquer la colonnette à la bonne distance.
The distance between the wall and the wall column is not adjustable, provide an offset with the wall or a system to place the column at the right distance.

VPDOUILLE0136

Entraîneur
Coupling adapter

VANNE PAPILLON TECWAT

Tecwat butterfly valve

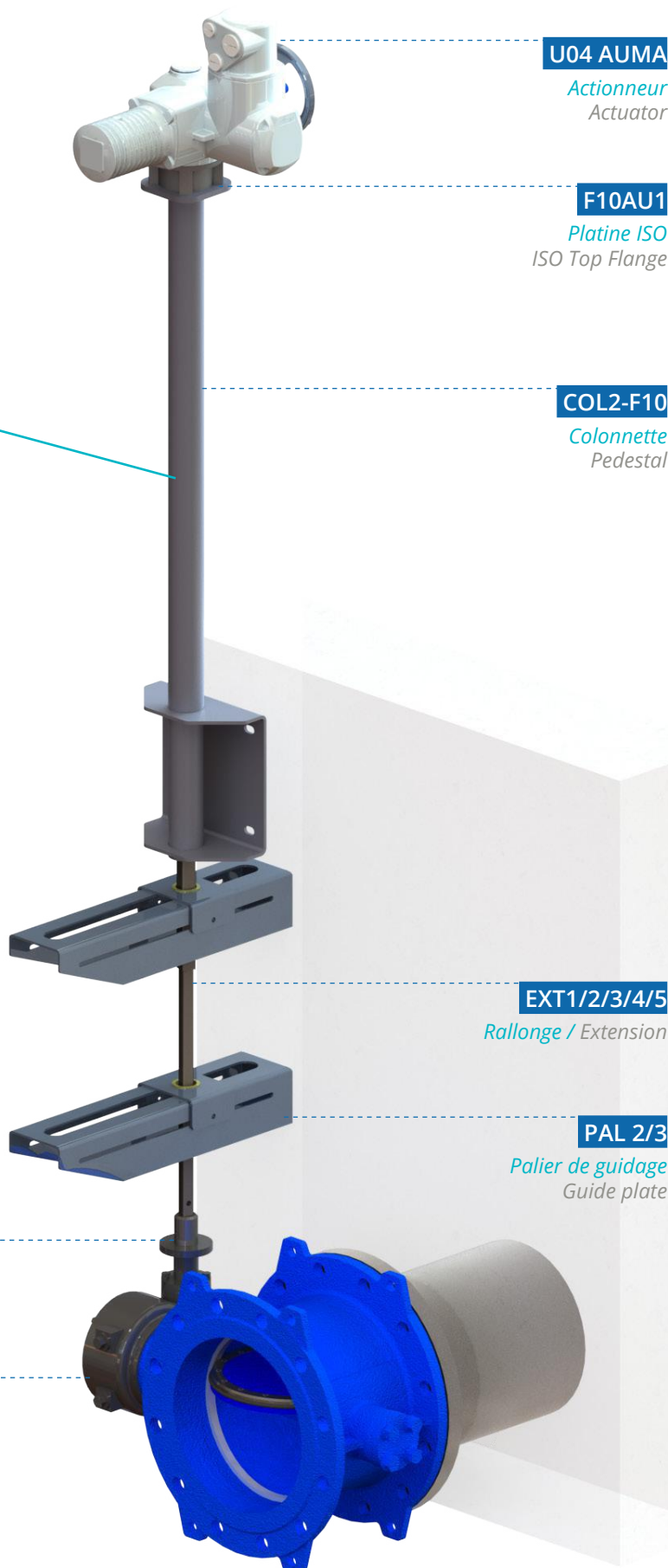

U04 AUMA

Actuateur
Actuator

F10AU1

Platine ISO
ISO Top Flange

COL2-F10

Colonnnette
Pedestal

EXT1/2/3/4/5

Rallonge / Extension

PAL 2/3

Palier de guidage
Guide plate

Représentation à titre indicatif (contre-bridés et tirants non représentés, ils sont obligatoires dans toutes installations).
Representation for reference only (counter flanges and tie rods not shown are required in all installations).



TRINGLERIES POUR MONTAGE SUR COLONNETTE - TECWAT LINKAGE FOR PEDESTAL MOUNTED - TECWAT

ENTRAINEUR | COUPLING ADAPTER

Entraîneur Femelle pour tige de rallonge (EXT)

Female coupling adapter for EXTENSION



Matière : Inox 304

Material: Stainless Steel 304

Ref.	DN
VPDOUILLE0136	350-600

RALLONGE | EXTENSION

Rallonge télescopique

Telescopic spindle extension



Matière : Inox 316L

Material: Stainless Steel 316L

Dimension (mm)	Ref.
800-1100	EXT1
1100-1750	EXT2
1750-3000	EXT3
3000-5500	EXT4
4000-8000	EXT5

PALIER DE GUIDAGE | GUIDE PLATE

Palier de guidage fixe pour rallonge télescopique EXT

Guide plate bearing for telescopic extension EXT



Matière : Inox 316L

Material: Stainless steel 316L

Dimension (mm)	Ref.
70-200	PAL2
70-500	PAL3



Mettre obligatoirement un palier tous les deux mètres + un autre avant le passage dans la colonnette.
Place one guide plate every two meters of the extension + one guide plate just before the pedestal floor.

COLONNETTES | PEDESTAL

Colonnette pour vannes à papillon

Floor stand for butterfly valves

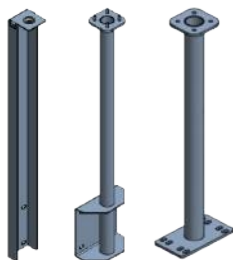

1

2

3



COL1 : pour commande par volant et fixation murale
COL2-F10 : pour commande motorisée et fixation murale
COL3-F10 : pour fixation au sol

Matière : Inox 304
Hauteur fixe : 900mm

Pedestal wall mounted for handwheel
Pedestal wall mounted for electric actuator
Pedestal floor mounted

Material: Stainless Steel 304
Height: 900mm

Ref.
COL1
COL2-F10
COL3-F10



PLAQUE DE GUIDAGE | SUPPORT PLATE

Plaque de guidage pour colonette fixation sol et commande par volant
Support plate for pedestal floor mounted handwheel



Matière : POM

Material: POM

Ref.

GUICOL



Permet de guider la rallonge
Used to guide the extension



A utiliser obligatoirement en cas de commande par volant sur colonnette COL3-F10.
To use only with handwheel operation on pedestal COL3-F10.

VOLANT | HANDWHEEL

Volant
Handwheel



Matière : Acier revêtu Epoxy
VOL1 : Diamètre 300mm
VOL2 : Diamètre 500mm

Material: Epoxy-coated carbon steel
VOL1: Diameter 300mm
VOL2: Diameter 500mm

Ref.	DN	
	mm	inch
VOL1	50-300	2"-12"
VOL2	350-600	14"-24"

PLATINE ISO POUR MOTEUR | ISO TOP FLANGE FOR ACTUATOR

Platine F10 pour moteur Auma montage sur EXT
ISO Top Flange for Auma actuator on EXT

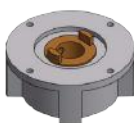

Matière : Fonte, écrou en bronze
Platine : ISO5210
Pour montage sur colonnette

Material: Cast iron, bronze nut
Top mounted flange: ISO5210
For assembly on column

Ref.

F10AU1

U04 - MOTEUR TECWAT - COLONNETTE | AUMA ACTUATOR FOR PEDESTAL MOUNTED TECWAT

Motorisation Auma 3 phases 400V/50Hz On/Off
3-phase Auma actuator 400V/50Hz On/Off



auma
Solutions for a world in motion



Moteur équipé de :
- 2 contacts fin de course
- 1 résistance de chauffe
- 2 limiteurs de couple
Commande manuelle de secours
Indicateur visuel de position
Protection IP68

Actuator equipped with:
- 2 limit switches
- 1 heat resistor
- 2 torque limiters included
Emergency handwheel
Visual position indicator
IP68 protection

		PN10		PN16	
DN		Ref.		Ref.	
mm	inch				
100	4"	SA07.2-U04B1TOR22		SA07.2-U04B1TOR22	
150	6"	SA07.2-U04B1TOR22		SA07.2-U04B1TOR22	
200	8"	SA07.6-U04B1TOR32		SA07.6-U04B1TOR32	
250	10"	SA07.6-U04B1TOR32		SA10.2-U04B1TOR45	
300	12"	SA10.2-U04B1TOR45		SA10.2-U04B1TOR45	
350	14"	SA10.2-U04B1TOR45		SA10.2-U04B1TOR45	
400	16"	SA10.2-U04B1TOR45		SA10.2-U04B1TOR45	
450	18"	SA10.2-U04B1TOR45		SA10.2-U04B1TOR63	
500	20"	SA07.6-U04B1TOR63		SA10.2-U04B1TOR63	
600	24"	SA10.2-U04B1TOR63		SA10.2-U04B1TOR63	

*Pour tout DN supérieur, PN25/ASA150 et PN40 nous consulter / Larger DN: PN25/ASA150 and PN40 on request

VP SERIE 13

DOUBLE EXCENTRIQUE DOUBLE BRIDE
DOUBLE ECCENTRIC DOUBLE FLANGED
DN 80-2000 - PN10/16

NEW



Nouvelle gamme: double bride construction suivant EN593

- ✓ Montage facile et manipulations de maintenance optimisées.
- ✓ Faible couple de manœuvre, économie d'énergie.
- ✓ Axe de manœuvre acier Inoxydable 420.
- ✓ Longue durée de vie, fiabilité.
- ✓ Excellente performance de régulation.
- ✓ Ecartement suivant EN558 SERIE 13.
- ✓ Raccordement par brides suivant EN1092-2.
- ✓ Manœuvre par réducteur manuel motorisable à volant avec indicateur visuel de position IP66.

New range : double flanged design according to EN593

- ✓ Easy assembly and optimized maintenance handling.
- ✓ Low operating torque, energy saving.
- ✓ Control stem in Stainless steel 420.
- ✓ Long operating life, reliable.
- ✓ Excellent regulating performance.
- ✓ Face to face according EN558 SERIES 13.
- ✓ Ends flanged according EN1090-2.
- ✓ IP66 gearbox with handwheel, visual indicator and ISO top flange for electric actuator.

VP4208A-08 | VP4248A-08

Vanne papillon double excentrique double bride
Double flanged, double eccentric butterfly valve



NEW



Corps et papillon : Fonte ductile
GJS500-7 (GGG50)
Siège : Acier inoxydable 304
Joint de papillon : EPDM
Boulonnerie : Inox 304
Raccordement : À brides

Body and disc: Ductile iron
GJS500-7 (GGG50)
Seat: Stainless steel 304
Seal ring on disc: EPDM
Bolts and nuts: Stainless steel 304
Connection: Flanged

Manœuvre par réducteur manuel
motorisable à volant avec
indicateur visuel d'ouverture IP66

IP66 gearbox with handwheel,
visual indicator and ISO top flange
for electric actuator

DN			PN10		PN16	
mm	inch	L (mm)	Ref.	Kg	Ref.	Kg
80	3"	-	-	-	VP4248A-08EP0080	18
100	4"	-	-	-	VP4248A-08EP0100	30
150	6"	-	-	-	VP4248A-08EP0150	45
200	8"	152	VP4208A-08EP0200	65	VP4248A-08EP0200	80
250	10"	165	VP4208A-08EP0250	75	VP4248A-08EP0250	94
300	12"	178	VP4208A-08EP0300	84	VP4248A-08EP0300	105
350	14"	190	VP4208A-08EP0350	120	VP4248A-08EP0350	150
400	16"	216	VP4208A-08EP0400	170	VP4248A-08EP0400	196
450	18"	222	VP4208A-08EP0450	190	VP4248A-08EP0450	238
500	20"	229	VP4208A-08EP0500	291	VP4248A-08EP0500	335
600	24"	267	VP4208A-08EP0600	348	VP4248A-08EP0600	371
700	28"	292	VP4208A-08EP0700	523	VP4248A-08EP0700	645
800	32"	318	VP4208A-08EP0800	720	VP4248A-08EP0800	900
900	36"	330	VP4208A-08EP0900	850	VP4248A-08EP0900	1063
1000	40"	410	VP4208A-08EP1000	1109	VP4248A-08EP1000	1386
1200	48"	470	VP4208A-08EP1200	1561	VP4248A-08EP1200	1850
1400	56"	530	VP4208A-08EP1400	2350	VP4248A-08EP1400	2980
1600	64"	600	VP4208A-08EP1600	3600	VP4248A-08EP1600	4000
1800	72"	670	VP4208A-08EP1800	4230	VP4248A-08EP1800	4700
2000	80"	760	VP4208A-08EP2000	5490	VP4248A-08EP2000	6100





VANNE À PAPILLON DOUBLE EXCENTRIQUE DOUBLE BRIDE SÉRIE 13 - MOTORISÉE
DOUBLE ECCENTRIC DOUBLE FLANGED BUTTERFLY VALVE SERIE 13 - ACTUATED

SERIE 13

VP4208A-U04EP | VP4248A-U04EP

SERIE 13 AUMA

Vanne à papillon à double excentration SERIE 13 avec motorisation AUMA 400V/50Hz on/off
Double eccentric type butterfly valve SERIE 13 with AUMA electric actuator 3-phase 400V/50Hz



Moteur équipé de :
- 2 contacts fin de course
- 1 résistance de chauffe
- 2 limiteurs de couple
Commande manuelle de secours
Indicateur visuel de position
Protection IP68

Actuator equipped with:
- 2 limit switches
- 1 heat resistor
- 2 torque limiters
Emergency handwheel
Visual position indicator
IP68 protection

DN			PN10		PN16	
mm	inch	L (mm)	Ref.	Kg	Ref.	Kg
100	4"	-	voir / see PN16		VP4248A-U04EP0100	49
150	6"	-	voir / see PN16		VP4248A-U04EP0150	64
200	8"	152	VP4208A-U04EP0200	84	VP4248A-U04EP0200	105
250	10"	165	VP4208A-U04EP0250	95	VP4248A-U04EP0250	119
300	12"	178	VP4208A-U04EP0300	104	VP4248A-U04EP0300	130
350	14"	190	VP4208A-U04EP0350	195	VP4248A-U04EP0350	175
400	16"	216	VP4208A-U04EP0400	195	VP4248A-U04EP0400	221
450	18"	222	VP4208A-U04EP0450	215	VP4248A-U04EP0450	263
500	20"	229	VP4208A-U04EP0500	316	VP4248A-U04EP0500	366
600	24"	267	VP4208A-U04EP0600	379	VP4248A-U04EP0600	402
700	28"	292	VP4208A-U04EP0700	554	VP4248A-U04EP0700	693
800	32"	318	VP4208A-U04EP0800	768	VP4248A-U04EP0800	948
900	36"	330	VP4208A-U04EP0900	898	VP4248A-U04EP0900	1111
1000	40"	410	VP4208A-U04EP1000	1157	VP4248A-U04EP1000	1434
1200	48"	470	VP4208A-U04EP1200	1609	VP4248A-U04EP1200	1898
1400	56"	530	VP4208A-U04EP1400	2398	VP4248A-U04EP1400	3033
1600	64"	600	VP4208A-U04EP1600	3653	VP4248A-U04EP1600	4053
1800	72"	670	VP4208A-U04EP1800	4283	VP4248A-U04EP1800	4753
2000	80"	760	VP4208A-U04EP2000	5543	VP4248A-U04EP2000	6153

VP4208A-B04EP | VP4248A-B04EP

SERIE 13 BERNARD CONTROLS

Vanne à papillon à double excentration SERIE 13 avec motorisation BERNARD CONTROLS 400V/50Hz on/off
Double eccentric type butterfly valve SERIE 13 with BERNARD CONTROLS electric actuator 3-phase 400V/50Hz



Moteur équipé de :
- 4 contacts fin de course
- 1 résistance de chauffe
- 2 limiteurs de couple
Commande manuelle de secours
Indicateur visuel de position
Protection IP68

Actuator equipped with:
- 4 limit switches
- 1 heat resistor
- 2 torque limiters switches
Emergency handwheel
Visual position indicator
IP68 protection

DN			PN10		PN16	
mm	inch	L (mm)	Ref.	Kg	Ref.	Kg
100	4"	-	voir / see PN16		VP4248A-B04EP0100	55
150	6"	-	voir / see PN16		VP4248A-B04EP0150	70
200	8"	152	VP4208A-B04EP0200	90	VP4248A-B04EP0200	128
250	10"	165	VP4208A-B04EP0250	123	VP4248A-B04EP0250	142
300	12"	178	VP4208A-B04EP0300	132	VP4248A-B04EP0300	153
350	14"	190	VP4208A-B04EP0350	168	VP4248A-B04EP0350	198
400	16"	216	VP4208A-B04EP0400	218	VP4248A-B04EP0400	244
450	18"	222	VP4208A-B04EP0450	238	VP4248A-B04EP0450	302
500	20"	229	VP4208A-B04EP0500	339	VP4248A-B04EP0500	383
600	24"	267	VP4208A-B04EP0600	396	VP4248A-B04EP0600	419
700	28"	292	VP4208A-B04EP0700	571	VP4248A-B04EP0700	709
800	32"	318	VP4208A-B04EP0800	784	VP4248A-B04EP0800	964
900	36"	330	VP4208A-B04EP0900	914	VP4248A-B04EP0900	1127
1000	40"	410	VP4208A-B04EP1000	1173	VP4248A-B04EP1000	1450
1200	48"	470	VP4208A-B04EP1200	1625	VP4248A-B04EP1200	1914
1400	56"	530	VP4208A-B04EP1400	2414	VP4248A-B04EP1400	3046
1600	64"	600	VP4208A-B04EP1600	3666	VP4248A-B04EP1600	4066
1800	72"	670	VP4208A-B04EP1800	4294	VP4248A-B04EP1800	4766
2000	80"	760	VP4208A-B04EP2000	5556	VP4248A-B04EP2000	6166

TECFLON PTFE

SÉCURITÉ ANTI ÉJECTION DE L'AXE

par circlips
Blowout-proof stem by circlips

MANCHETTE PTFE ÂME FPM

Épaisseur PTFE de 2 à 2.5 mm suivant DN.
Âme FPM apportant élasticité (autre matière sur demande)
PTFE sleeve FPM insert
*PTFE thickness from 2 to 2.5 mm according to DN
FPM insert to ensure elasticity (other versions on request)*

PAPILLON INOX 316 REVÊTU PTFE

Épaisseur PTFE de 4 à 7.5mm d'épaisseur suivant DN, variante papillon inox non revêtu
PTFE-coated Stainless steel 136 disc
PTFE thickness from 4 to 7.5 mm according to DN, un-lined stainless steel disc option

DISPOSITIF ASSURANT UNE PARFAITE ÉTANCHÉITÉ ET PROTECTION DE L'AXE

Paliers en FRP+PTFE
Rondelles belleville
Device ensuring perfect sealing and protection of the shaft
*FRP+PTFE shaft sleeve
Belleville washers*

POIGNÉE TECOFI TRIPLE FONCTION

Secteur cranté 10 positions, cadennassable en fonte ductile EN-GJS-400-15 anti corrosion (boulonnerie inox A2) et régulation.

Triple use Tecofi handle

10-positions notched locking quadrant, regulation function, lockable in ductile iron EN-GJS-400-15 anti corrosion (stainless steel A2 bolts and nuts).

PLATINE ISO 5211

Assemblage direct avec tous types de motorisation
ISO 5211 mounting plate
Direct assembly with all actuators

RACCORDEMENT

Entre brides PN10/16 ASA150
Connection between flanges
PN10/16 ASA150

CORPS EN 2 PARTIES

En fonte ductile EN-GJS-500-7 revêtu époxy
2-part body in ductile iron EN-GJS-500-7 epoxy coated

CONTROLE DIELECTRIQUE DU REVÊTEMENT PTFE

Dielectric control of PTFE coating

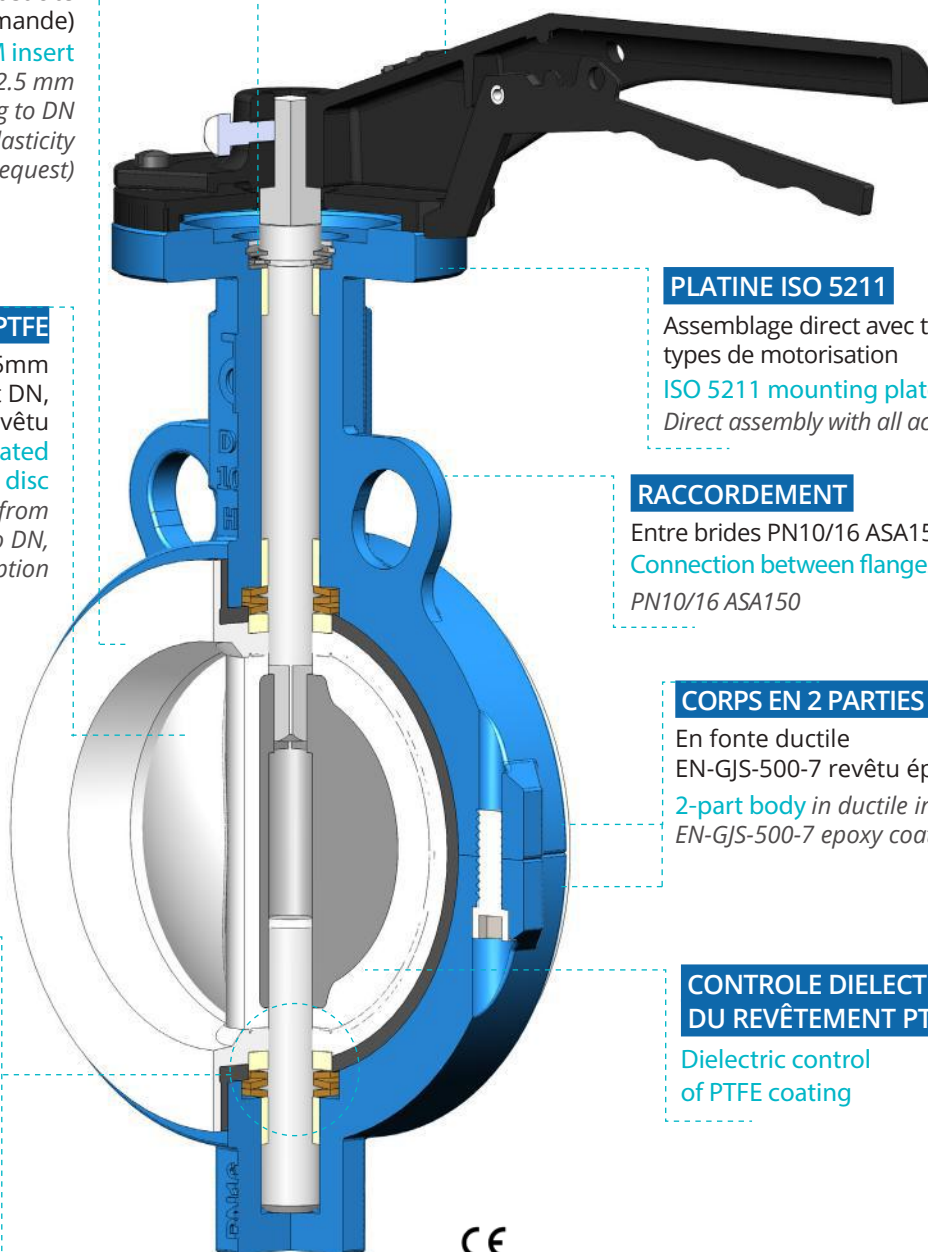

VP4449-02PTFE | VP4449-08PTFE

Vanne à papillon à oreilles de centrage - papillon inox - manchette PTFE
Wafer type butterfly valve - Stainless steel disc - PTFE sleeve



Modèle -08 / Model -08



Corps : Fonte ductile EN-GJS-500-7 (GGG50)
Papillon : Inox A351 CF8M
Manchette : PTFE avec âme FPM
Raccordement :
DN40-150 : entre brides PN10/16 - ASA150
DN200-300: PN10- ASA150
Pression de service : 16 bar jusqu'au DN150
au-delà 10 bar
Température de service : -20°C/+190°C

Body: Ductile iron EN-GJS-500-7 (GGG50)
Disc: Stainless steel A351 CF8M
Sleeve: PTFE with FPM insert
Connection:
DN40-150 : Between flanges PN10/16 - ASA150
DN200-300 : PN10 - ASA150
Working pressure: 16 bar to DN150
10 bar for over sizes
Working temperature: -20°C/+190°C

Triple-use handle up to DN100
With gearbox from DN125

Poignée triple fonctions jusqu'au DN100
Réducteur manuel à partir du DN125

 ATEX sur demande / ATEX on demand

CE

Poignée / Handle				
DN		L (mm)	Kg	Ref.
mm	inch			
40	1"1/2	47	2,75	VP4449-02PTFE0040
50	2"	47	2,75	VP4449-02PTFE0050
65	2"1/2	50	3,2	VP4449-02PTFE0065
80	3"	50	3,65	VP4449-02PTFE0080
100	4"	55,5	5,05	VP4449-02PTFE0100

Réducteur manuel / Gearbox				
DN		L (mm)	Kg	Ref.
mm	inch			
125	5"	59	10,55	VP4449-08PTFE0125
150	6"	59	11,35	VP4449-08PTFE0150
200	8"	63	18,80	VP4449-08PTFE0200
250	10"	73	26,60	VP4449-08PTFE0250
300	12"	81	40,47	VP4449-08PTFE0300

VP4649-02PTFE | VP4649-08PTFE

Vanne à papillon à oreilles taraudées - papillon inox - manchette PTFE
Lug type butterfly valve - Stainless steel disc - PTFE sleeve



Modèle -08 / Model -08



Corps : Fonte ductile EN-GJS-500-7 (GGG50)
Papillon : Inox A351 CF8M
Manchette : PTFE avec âme FPM
Raccordement : oreilles taraudées
DN40-150 : PN10/16
DN200-300: PN10
Pression de service : 16 bar jusqu'au DN150
au-delà 10 bar
Température de service : -20°C/+190°C

Body: Ductile iron EN-GJS-500-7 (GGG50)
Disc: Stainless steel A351 CF8M
Sleeve: PTFE with FPM insert
Connection: Lugged
DN40-150 : PN10/16
DN200-300: PN10
Working pressure: 16 bar to DN150 - 10 bar
for over sizes
Working temperature: -20°C/+190°C

Triple-use handle up to DN100
With gearbox from DN125

Poignée triple fonctions jusqu'au DN100
Réducteur manuel à partir du DN125

 ATEX sur demande / ATEX on demand

CE

Poignée / Handle				
DN		L (mm)	Kg	Ref.
mm	inch			
40	1"1/2	47	3,47	VP4649-02PTFE0040
50	2"	47	3,47	VP4649-02PTFE0050
65	2"1/2	50	4,10	VP4649-02PTFE0065
80	3"	50	4,55	VP4649-02PTFE0080
100	4"	55,5	6,80	VP4649-02PTFE0100

Réducteur manuel / Gearbox				
DN		L (mm)	Kg	Ref.
mm	inch			
125	5"	59	13,09	VP4649-08PTFE0125
150	6"	59	13,45	VP4649-08PTFE0150
200	8"	63	23,85	VP4649-08PTFE0200
250	10"	73	32,40	VP4649-08PTFE0250
300	12"	81	50,67	VP4649-08PTFE0300



Accessoires disponibles : boîtiers fin de course, électrodistributeurs pages 57 à 64
Accessories : limit switches box, solenoid valve pages 57 up to 64



VP4449R-02PTFE | VP4449R-08PTFE

Vanne à papillon à oreilles de centrage - papillon et manchette PTFE

Wafer type butterfly valve - PTFE sleeve and disc



Corps : Fonte ductile EN-GJS-500-7 (GGG50)
Papillon : Inox A351 CF8M revêtu PTFE
Manchette : PTFE avec âme FPM
Raccordement : Entre brides PN10/16 jusqu'au DN150 - PN10 au-delà - ASA150
Pression de service : 16 bar jusqu'au DN150 - au-delà 10 bar
Température de service : -20°C/+190°C

Body: Ductile iron EN-GJS-500-7 (GGG50)
Disc: Stainless steel A351 CF8M PTFE coated
Sleeve: PTFE with FPM insert
Connection: Between flanges PN10/16 to DN150 - PN10 for larger sizes - ASA150
Working pressure: 16 bar up to DN150 - 10 bar for larger sizes
Working temperature: -20°C/+190°C

CE Modèle -08 / Model -08



Papillon PTFE
PTFE disc

Poignée / Handle				
DN		L (mm)	Kg	Ref.
mm	inch			
40	1"1/2	47	2,9	VP4449R-02PTFE0040
50	2"	47	2,9	VP4449R-02PTFE0050
65	2"1/2	50	3,36	VP4449R-02PTFE0065
80	3"	50	3,81	VP4449R-02PTFE0080
100	4"	55,5	5,3	VP4449R-02PTFE0100

Réducteur manuel / Gearbox				
DN		L (mm)	Kg	Ref.
mm	inch			
125	5"	59	10,93	VP4449R-08PTFE0125
150	6"	59	11,8	VP4449R-08PTFE0150
200	8"	63	19,8	VP4449R-08PTFE0200
250	10"	73	28	VP4449R-08PTFE0250
300	12"	81	42,6	VP4449R-08PTFE0300

Ex ATEX sur demande / ATEX on demand

VP4649R-02PTFE | VP4649R-08PTFE

Vanne à papillon à oreilles taraudées - papillon et manchette PTFE

Lug type butterfly valve - PTFE sleeve and disc



Corps : Fonte ductile EN-GJS-500-7 (GGG50)
Papillon : Inox A351 CF8M revêtu PTFE
Manchette : PTFE avec âme FPM
Raccordement : Oreilles taraudées PN10/16 jusqu'au DN150 - PN10 au-delà
Pression de service : 16 bar jusqu'au DN150 - au-delà 10 bar
Température de service : -20°C/+190°C

Body: Ductile iron EN-GJS-500-7 (GGG50)
Disc: Stainless steel A351 CF8M PTFE coated
Sleeve: PTFE with FPM insert
Connection: Lugged PN10/16 to DN150 - PN10 for larger sizes
Working pressure: 16 bar up to DN150 - 10 bar for larger sizes
Working temperature: -20°C/+190°C

CE Modèle -08 / Model -08



Papillon PTFE
PTFE disc

Poignée / Handle				
DN		L (mm)	Kg	Ref.
mm	inch			
40	1"1/2	47	3,85	VP4649R-02PTFE0040
50	2"	47	3,85	VP4649R-02PTFE0050
65	2"1/2	50	4,55	VP4649R-02PTFE0065
80	3"	50	5,05	VP4649R-02PTFE0080
100	4"	55,5	7,55	VP4649R-02PTFE0100

Réducteur manuel / Gearbox				
DN		L (mm)	Kg	Ref.
mm	inch			
125	5"	59	14,15	VP4649R-08PTFE0125
150	6"	59	14,55	VP4649R-08PTFE0150
200	8"	63	26,5	VP4649R-08PTFE0200
250	10"	73	36	VP4649R-08PTFE0250
300	12"	81	56,30	VP4649R-08PTFE0300





ACCESSOIRES POUR TECFLON
ACCESSORIES FOR TECFLON



TECFLON

REDUCTEUR -08 | -08 GEARBOX

Réducteur mécanique pour vanne papillon Tecflon
Gearbox for Tecflon butterfly valve

DN		Ref. TECFLON
mm	inch	
40-80	1"1/2-3"	300190357
100	4"	300190358



Corps : Aluminium
Indicateur visuel de position

Body: Aluminium
Visual indicator position



Livré avec vis, rondelle (A2)
Supplied with bolt, washer (A2)



Les volants peuvent être livrés démontés pour l'optimisation de l'envoi. Nous vous invitons à spécifier le montage du volant lors de votre commande si impératif (coût de montage en sus).
Handwheels are delivered disassembled for the optimization of the shipment. Please contact us if it is imperative that the valve is shipped with handwheel assembled.



NEW

EN OPTION | OPTION

Kit cadénassable pour réducteur 08
Padlock kit for gearbox 08

Système de blocage du réducteur par cadenas composé de :

- Plaque de verrouillage
- Bague de verrouillage
- Cadenas

Padlock blocking system for gearbox, comprised of:

- Locking plate
- Locking ring
- Padlock

DN		Ref.
mm	inch	
40-100	1"1/2-4"	300200107

*Pour cadénassage sur TECFLON DN supérieur, nous consulter
Larger TECFLON padlock kit on request

ACTIONNEUR POUR GAMME TECFLON | ACTUATOR FOR TECFLON RANGE

ACTIONNEUR PNEUMATIQUE POUR VANNE PAPILLON TECFLON

Pneumatic actuator for TECFLON butterfly valves



ΔP max : 16 bar
Construction: Aluminium
Pression de service : 6 bar (air lubrifié)
Butées réglables

CE



Composé de :

- actionneur simple ou double effet
- douille d'adaptation
- arcade
- Came visuel de position

ΔP max: 16 bar
Construction: Aluminium
Working pressure: 6 bar (air lubricated)
Stop bolt retaining nut

Comprised of:

- pneumatic actuator
- machined metal piece
- metal sheet bracket
- Visual position cam



ATEX ZONE 1 / 2 / 21 / 22

DN		Double effet / Double-acting		Simple effet / Single-acting	
		Ref.KIT	Type	Ref.KIT	Type
40	1"1/2	300190342	TDA075	300190350	TSR105
50	2"				
65	2"1/2	300190343	TDA083	300190351	TSR125
80	3"				
100	4"	300190344	TDA092	300190352	TSR125
125	5"	300190345	TDA105	300190353	TSR160
150	6"	300190346	TDA125		
200	8"	300190347	TDA160	300190354	TSR210
250	10"	300190348	TDA160	300190355	TSR240
300	12"	300190349	TDA190	300190356	TSR270



Accessoires et options possibles pour vérin p.57 à 64
See accessories and options for pneumatic actuator p.57 up to 64



GAMME GAZ
GAS RANGE



Vanne à papillon idéale pour le sectionnement ou le réglage de réseaux de gaz. Certifiée NF ROB-GAZ et garantie 5 ans. Compatible pour les atmosphères explosives ATEX zone 1 & 21 (autres zones sur demande).
Wafer butterfly valve for closing or setting networks of gas. Valves with NF ROB-GAZ certification, 5 years warranty. Compatible with explosive atmosphere, Atex Zone 1 & 21 (other zones on request).

VP4449GZ-02NI | VP4448GZ-02NI

Vanne à papillon à oreilles de centrage à poignée pour usage Gaz
 Wafer butterfly valve with lever for Gas



Corps : Fonte ductile EN-GJS-500-7 (GGG50)
Papillon :
 DN 40-100 : Inox ASTM A351 CF8M
 DN 125-200 : Fonte ductile EN-GJS-500-7 revêtu Epoxy
Manchette : Nitrile gaz
Raccordement : Entre brides PN10/16/ASA150
Pression de service : Classe MOP 5
Température de service max : -20°C/+60°C
 ATEX Zone 1&21 et Zone 2&22 sur demande

Body: Ductile iron EN-GJS-500-7 (GGG50)
Disc:
 DN 40-100 : Stainless steel ASTM A 351 CF8M
 DN 125-200 : Ductile iron Epoxy coated EN-GJS-500-7
Sleeve: Gas NBR
Connection: Between flanges PN10/16/ASA150
Working pressure: MOP 5 Class
Maximum working temperature: -20°C/+60°C
 ATEX Zone 1&21 and Zone 2&22 on request



Certifié / certified : NF Rob-064-R3
Selon / according to : NF EN 13774, NF EN 549



Acier Inox | Stainless Steel

Papillon : Inox A351 CF8M Disc: Stainless steel A351 CF8M				
DN		L (mm)	Kg	Ref.
mm	inch			
40	1 1/2	33	2,4	VP4449GZ-02NI0040
50	2"	43	3,5	VP4449GZ-02NI0050
65	2 1/2	46	4,1	VP4449GZ-02NI0065
80	3"	46	4,7	VP4449GZ-02NI0080
100	4"	52	5,9	VP4449GZ-02NI0100



Fonte ductile | Ductile Iron

Papillon : Fonte ductile ENGJS-500-7 EPOXY Disc: Ductile iron ENGJS-500-7 EPOXY				
DN		L (mm)	Kg	Ref.
mm	inch			
125	5"	56	7,6	VP4448GZ-02NI0125
150	6"	56	8,7	VP4448GZ-02NI0150
200	8"	60	14	VP4448GZ-02NI0200

VP4649GZ-02NI | VP4648GZ-02NI

Vanne à papillon à oreilles taraudées à poignée pour usage Gaz
 Lug butterfly valve with lever for Gas



Corps : Fonte ductile EN-GJS-500-7 (GGG50)
Papillon :
 DN 50-100 : Inox ASTM A351 CF8M
 DN 125-200 : Fonte ductile EN-GJS-500-7 revêtu Epoxy
Manchette : Nitrile Gaz
Raccordement : Oreilles taraudées PN 10/16 - DN 200 PN10
Pression de service max : Classe MOP 5
Température de service max : -20°C/+60°C
 ATEX Zone 1&21 et Zone 2&22 sur demande

Body: Ductile Iron EN-GJS-500-7 (GGG50)
Disc:
 DN 50-100 : Stainless steel ASTM A 351 CF8M
 DN 125-200 : Ductile iron Epoxy coated EN-GJS-500-7
Sleeve: Gas NBR
Connection: Lug type PN10/16 - DN 200 PN10
Maximum working pressure: MOP 5 class
Maximum working temperature: -20°C/+60°C
 ATEX Zone 1&21 and Zone 2&22 on request



Certifié / certified : NF Rob-064-R3
Selon / according to : NF EN 13774, NF EN 549



Acier Inox | Stainless steel

Papillon : Inox A351 CF8M Disc: Stainless Steel A351 CF8M				
DN		L (mm)	Kg	Ref.
mm	inch			
40	1 1/2	33	2,7	VP4649GZ-02NI0040
50	2"	43	3,96	VP4649GZ-02NI0050
65	2 1/2	46	4,31	VP4649GZ-02NI0065
80	3"	46	5,52	VP4649GZ-02NI0080
100	4"	52	6,98	VP4649GZ-02NI0100



Fonte ductile | Ductile Iron

Papillon : Fonte ductile ENGJS-500-7 epoxy Disc: Ductile iron ENGJS-500-7 epoxy				
DN		L (mm)	Kg	Ref.
mm	inch			
125	5"	56	11,4	VP4648GZ-02NI0125
150	6"	56	11,6	VP4648GZ-02NI0150
200	8"	60	18,9	VP4648GZ-02NI0200



GAMME INDUSTRIE
INDUSTRIAL RANGE



Vanne à papillon idéale pour les fluides de réseau de vapeur, chauffage urbain, certifiée sécurité feu.
Wafer butterfly valve for heating, steam, certified fire safe.

VP5451-02 | VP5451-08

Acier - Sécurité feu | Carbon steel - Fire safe

Vanne à papillon haute performance à oreilles de centrage - double excentration - Acier - SECURITE FEU - ISO PN25

High performance wafer butterfly valve - double eccentric - Steel - FIRE SAFE - ISO PN25



Corps : ASTM A216 WCB
Papillon : ASTM A351 CF8M
Siège : PTFE + 15 % graphite
Raccordement : Entre-bridés PN25
Pression de service max : 25 bar
Température de service max : -20°C / +210°C
Commande par levier, avec réducteur au dessus du DN 150
ATEX Groupe II Cat. 2 G/2D Zone 1 & 21 Zone 2 & 22

Body: ASTM A216 WCB
Disc: ASTM A351 CF8M
Seat: PTFE +15% graphite
Connection: Wafer PN 25
Maximum working pressure: 25 bar
Maximum working temperature: -20°C / +210°C
Lever operator up through DN 150,
Gearbox operating above DN 150
ATEX Group II Category 2 G/2D Zone 1 & 21 Zone 2 & 22

DN		L (mm)	Kg	Poignée / Handle
mm	inch			Ref.
50	2"	43	4,6	VP5451-02PTF0050
65	2 1/2"	46	5,2	VP5451-02PTF0065
80	3"	47	7,8	VP5451-02PTF0080
100	4"	53	9,8	VP5451-02PTF0100
125	5"	57	13,6	VP5451-02PTF0125
150	6"	56	15,1	VP5451-02PTF0150

Réducteur / Gearbox

200	8"	62	29,5	VP5451-08PTF0200
250	10"	68	41	VP5451-08PTF0250
300	12"	78	70	VP5451-08PTF0300
350	14"	78	88	VP5451-08PTF0350
400	16"	102	142	VP5451-08PTF0400
450	18"	114	165	VP5451-08PTF0450
500	20"	127	198	VP5451-08PTF0500



VP6451-02 | VP6451-08

Inox - Sécurité feu | Stainless Steel - Fire safe

Vanne à papillon haute performance à oreilles de centrage - double excentration - Inox - SECURITE FEU - ISO PN25

High performance wafer butterfly valve - double eccentric - Stainless steel - ISO PN 25



Corps : ASTM A351 CF8M
Papillon : ASTM A351 CF8M
Siège : PTFE + 15 % graphite
Raccordement : Entre-bridés PN25
Pression de service max : 25 bar
Température de service max : -20°C / +210°C
Commande par levier, avec réducteur au dessus du DN 150
ATEX Groupe II Cat. 2 G/2D Zone 1 & 21 Zone 2 & 22

Body: ASTM A351 CF8M
Disc: ASTM A351 CF8M
Seat: PTFE +15% graphite
Connection: Wafer PN25
Maximum working pressure: 25 bar
Maximum working temperature: -20°C / +210°C
Lever operator up through DN 150,
Gearbox operating above DN 150
ATEX Group II Category 2 G/2D Zone 1 & 21 Zone 2 & 22

DN		L (mm)	Kg	Poignée / Handle
mm	inch			Ref.
50	2"	43	4,6	VP6451-02PTF0050
65	2 1/2"	46	5,2	VP6451-02PTF0065
80	3"	47	7,8	VP6451-02PTF0080
100	4"	53	9,8	VP6451-02PTF0100
125	5"	57	13,6	VP6451-02PTF0125
150	6"	56	15,1	VP6451-02PTF0150

Réducteur / Gearbox

200	8"	62	29,5	VP6451-08PTF0200
250	10"	68	41	VP6451-08PTF0250
300	12"	78	70	VP6451-08PTF0300
350	14"	78	88	VP6451-08PTF0350
400	16"	102	142	VP6451-08PTF0400
450	18"	114	165	VP6451-08PTF0450
500	20"	127	198	VP6451-08PTF0500



VP5441-02 | VP5441-08

Acier ISO PN20 ASA 150 - Sécurité feu | ASA 150 Carbon steel - Fire safe

Vanne à papillon haute performance à oreilles de centrage - double excentration - Acier - ISO PN20 ASA 150

High performance wafer butterfly valve - double eccentric - Steel - ISO PN20 ASA 150



Corps : ASTM A216 WCB
Papillon : ASTM A351 CF8M
Siège : PTFE +15% graphite
Raccordement : Entre-brides ASA150
Pression de service max : 20 bar
Température de service max : -20°C / +210°C
Commande par levier, avec réducteur au dessus du DN150
ATEX Groupe II Cat. 2 G/2D Zone 1 & 21 Zone 2 & 22

Body: ASTM A216 WCB
Disc: ASTM A351 CF8M
Seat: PTFE +15% graphite
Connection: Wafer ASA150
Maximum working pressure: 20 bar
Maximum working temperature: -20°C / +210°C
Lever operator up through DN 150,
Gearbox operating above DN 150
ATEX Group II Category 2 G/2D Zone 1 & 21 Zone 2 & 22



DN		L (mm)	Kg	Poignée / Handle
mm	inch			Ref.
50	2"	43	4,6	VP5441-02PTF0050
65	2 1/2"	46	5,2	VP5441-02PTF0065
80	3"	47	7,8	VP5441-02PTF0080
100	4"	53	9,8	VP5441-02PTF0100
125	5"	57	13,6	VP5441-02PTF0125
150	6"	56	15,1	VP5441-02PTF0150

Réducteur / Gearbox

200	8"	62	29,5	VP5441-08PTF0200
250	10"	68	41	VP5441-08PTF0250
300	12"	78	70	VP5441-08PTF0300
350	14"	78	88	VP5441-08PTF0350
400	16"	102	142	VP5441-08PTF0400
450	18"	114	165	VP5441-08PTF0450
500	20"	127	198	VP5441-08PTF0500

VP6441-02 | VP6441-08

Inox ISO PN20 ASA 150 - Sécurité feu | ASA 150 SS - Fire safe

Vanne à papillon haute performance à oreilles de centrage - double excentration - Inox - ISO PN20 ASA 150

High performance wafer butterfly valve - double eccentric - Stainless steel - ISO PN20 ASA 150



Corps : ASTM A351 CF8M
Papillon : ASTM A351 CF8M
Siège : PTFE +15% graphite
Raccordement : Entre-brides ASA150
Pression de service max : 20 bar
Température de service max : -20°C / +210°C
Commande par levier, avec réducteur au dessus du DN150
ATEX Groupe II Cat. 2 G/2D Zone 1 & 21 Zone 2 & 22

Body: ASTM A351 CF8M
Disc: ASTM A351 CF8M
Seat: PTFE +15% graphite
Connection: Wafer ASA150
Maximum working pressure: 20 bar
Maximum working temperature: -20°C / +210°C
Lever operator up through DN150,
gearbox operating above DN150
ATEX Group II Category 2 G/2D Zone 1 & 21 Zone 2 & 22



DN		L (mm)	Kg	Poignée / Handle
mm	inch			Ref.
50	2"	43	4,6	VP6441-02PTF0050
65	2 1/2"	46	5,2	VP6441-02PTF0065
80	3"	47	7,8	VP6441-02PTF0080
100	4"	53	9,8	VP6441-02PTF0100
125	5"	57	13,6	VP6441-02PTF0125
150	6"	56	15,1	VP5441-02PTF0150

Réducteur / Gearbox

200	8"	62	29,5	VP6441-08PTF0200
250	10"	68	41	VP6441-08PTF0250
300	12"	78	70	VP6441-08PTF0300
350	14"	78	88	VP6441-08PTF0350
400	16"	102	142	VP6441-08PTF0400
450	18"	114	165	VP6441-08PTF0450
500	20"	127	198	VP6441-08PTF0500

VPREDUCT-TECSUP

Réducteur manuel pour vannes haute performance

Gearbox for high performance butterfly valves



DN		Ref.
mm	inch	
50-65	2"-2 1/2"	VPREDUCT-TECSUP050
80	3"	VPREDUCT-TECSUP080
100	4"	VPREDUCT-TECSUP100
125-150	5"-6"	VPREDUCT-TECSUP125

VANNE PAPILLON TRIPLE EXCENRATION | TRIPLE OFFSET TYPE BUTTERFLY VALVE



Modèles à bride, entre
bride, oreilles taraudées et à
souder. Consultez-nous !
Lugged, flanged and welded
types. Consult us!

VP5447-02 | VP6447-02

Étanchéité relative | Relative tightness

Vanne à papillon à oreilles de centrage - métal / métal - PN16 - étanchéité relative
Wafer butterfly valve - metal / metal - PN16 - Relative seal



VP5447-02 :
Corps : A216WCB
Papillon : ASTM A351 CF8M
jusqu'au DN100 - au delà Fonte ductile EN-GJS-500-7

VP6447-02 :
Corps : ASTM A351 CF8M
Papillon : ASTM A351 CF8M

Body: A216WCB
Disc: ASTM A351 CF8M up through DN100 - above DN 125 ductile iron EN-GJS-500-7

Body: ASTM A351 CF8M
Disc: ASTM A351 CF8M

Tightness : Metal / metal
Not 100% tight, loss factor : 1,5 to 2% of KVS
Connection:
Wafer PN10/16/ASA150
Maximum working pressure: 16 bar
Maximum working temperature: +20°C / +350 °C
ATEX Group II Category 2 G/2D Zone 1 & 21 Zone 2 & 22

Étanchéité : Métal / métal
Non étanche, coefficient de perte : 1,5 à 2% du KVS
Raccordement :
Entre-brides PN10/16/ASA150
Pression de service max : 16 bar
Température max : +20°C / +350°C
ATEX Group II Cat. 2 G/2D Zone 1 & 21 Zone 2 & 22



DN		L (mm)	Kg	Acier / Steel	Inox / Stainless steel
mm	inch			Ref.	Ref.
40	1 1/2	33	3,1	VP5447-02MM0040	VP6447-02MM0040
50	2"	43	4,27	VP5447-02MM0050	VP6447-02MM0050
65	2 1/2	46	5,27	VP5447-02MM0065	VP6447-02MM0065
80	3"	46	5,78	VP5447-02MM0080	VP6447-02MM0080
100	4"	52	7,4	VP5447-02MM0100	VP6447-02MM0100
125	5"	56	10,15	VP5447-02MM0125	VP6447-02MM0125
150	6"	56	11,74	VP5447-02MM0150	VP6447-02MM0150
200	8"	60	19,6	VP5447-02MM0200	VP6447-02MM0200



**VANNES
À PAPILLON
TECOFI®
BUTTERFLY
VALVES**



NOTICE D'INSTALLATION ET D'UTILISATION USE AND INSTALLATION NOTE



VANNES À PAPILLON BUTTERFLY VALVES

INSTALLATION ET MISE EN SERVICE

Vérifier que le robinet peut s'insérer entre les brides sans difficulté et sans endommager la manchette. (Voir Fig. 2)

Positionner le papillon 1/4 ouvert pour effectuer le montage. (Voir Fig. 3)

Ne pas utiliser de joint entre le robinet à papillon et les brides. (Voir Fig. 5)

Vérifier que le diamètre intérieur des brides est conforme aux dimensions du tableau «Diamètre intérieur des brides» (Voir Fig. 1). Pour les robinets à papillon de grandes dimensions avec actionneur (Gamme TECLARGE), dans le cas où les robinets sont installés verticalement, il est nécessaire de procéder par étapes :

1. Monter les actionneurs avec les robinets à l'horizontale.
2. Ensuite, positionner l'ensemble monté «robinet + actionneur» à la verticale.

Si le montage des actionneurs est réalisé sur les robinets en position verticale, il peut y avoir des problèmes de descente du papillon par rapport à la manchette et ainsi créer une fuite.

Avant la mise en service, vérifier que l'indicateur sur la commande ou que la position de la poignée, indique bien la position du papillon.

Sur une installation neuve ou après une maintenance, le circuit devra être rincé avec le robinet à papillon totalement ouvert afin d'évacuer les corps solides qui risqueraient d'endommager les parties internes du robinet.

INSTALLATION AND COMMISSIONING

Verify that the valve can fit between flanges without any trouble and without damaging the sleeve. (See Fig. 2)

Put the disc in 1/4 open position before carrying out the assembly. (See Fig. 3)

Do not use gasket between the butterfly valve and the flanges. (See Fig. 5)

Verify that the internal diameter of flanges is in compliance with the dimensions of the table «internal diameter of flanges» (See Fig. 1).

For large-diameter butterfly valves with actuators (Range TECLARGE), in the case when valves are vertically installed, it is necessary to follow the following steps:

1. Assemble actuators with valves horizontal.
2. Then place the valve-actuator assembly in the upright position. If actuators are assembled while the valve is upright, the disc may descend in regards to the sleeve and can cause leaks.

Before the start-up, verify that the indicator on the actuator or the position of the handle correctly indicates the position of the disc.

During installation or after maintenance, the circuit must be rinsed with the butterfly completely open to evacuate any solid particles that could risk damaging the internal parts of the valve.

! Le montage des vannes à papillon sur collets PVC n'est possible que si les collets sont chanfreinés.

Butterfly valves can be installed with PVC collars only if the collars are beveled.

RACCORDEMENT ISO PN 10 POUR BRIDE TYPE 11B / FLANGED ISO PN 10 FOR FLANGE TYPE 11B

DN		Raccordement de la bride Flange connection			Equipement pour montage entre 2 brides Equipment for assembling between 2 flanges				
		Diamètre extérieur Ø D External diameter	Diamètre de perçage des trous Ø K Drilling circle	Nombre de trous x Ø L Hole number x Ø L	TECFLY / TECLARGE		TECFLY LUG	TECLARGE FL	
					Boulons (rouge) Nombre x M-l Bolt (red) Number x M-lg	Vis (jaune) Nombre x M-l Screw (yellow) Number x M-lg	Vis (jaune) Nombre x M-l Screw (yellow) Number x M-lg	Boulons (rouge) Nombre x M-l Bolt (red) Number x M-lg	Vis (jaune) Nombre x M-l Screw (yellow) Number x M-lg
mm	inch	mm	mm	mm	TYPE 1 mm	TYPE 3 mm	TYPE 2 mm	TYPE 3 mm	TYPE 3 mm
40	1" 1/2	150	110	4 x 18	4 x M 16-100	-	8 x M 16-30	-	-
50	2"	165	125	4 x 18	4 x M 16-110	-	8 x M 16-35	-	-
65	2" 1/2	185	145	4 x 18	4 x M 16-120	-	8 x M 16-35	-	-
80	3"	200	160	8 x 18	8 x M 16-120	-	16 x M 16-40	-	-
100	4"	220	180	8 x 18	8 x M 16-130	-	16 x M 16-40	-	-
125	5"	250	210	8 x 18	8 x M 16-130	-	16 x M 16-45	-	-
150	6"	285	240	8 x 22	8 x M 20-140	-	16 x M 20-45	-	-
200	8"	340	295	8 x 22	8 x M 20-150	-	16 x M 20-50	-	-
250	10"	395	350	12 x 22	12 x M 20-160	-	24 x M 20-55	-	-
300	12"	445	400	12 x 22	12 x M 20-170	-	24 x M 20-60	-	-
350	14"	505	460	16 x 22	16 x M 20-170	-	-	16 x M 20-170	-
400	16"	565	515	16 x 26	16 x M 24-220	-	-	16 x M 24-200	-
450	18"	615	565	20 x 26	20 x M 24-130	-	-	20 x M 24-220	-
500	20"	670	620	20 x 26	20 x M 24-230	-	-	20 x M 24-240	-
600	24"	780	725	20 x 30	20 x M 27-260	-	-	20 x M 27-260	-
700	28"	895	840	24 x 30	24 x M 27-270	-	-	20 x M 27-280	8 x M 27-70
800	32"	1015	950	24 x 33	24 x M 30-300	-	-	20 x M 30-300	8 x M 30-120
900	36"	1115	1050	28 x 33	24 x M30-320	8 x M30-70	-	24 x M30-320	8 x M 30-70
1000	40"	1230	1160	28 x 36	24 x M 33-340	8 x M 33-70	-	24 x M 33-340	8 x M 33-70
1200	48"	1455	1380	32 x 39	28 x M 36-390	8 x M 36-80	-	28 x M 36-390	8 x M 36-75

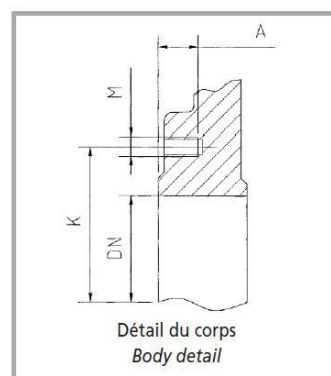
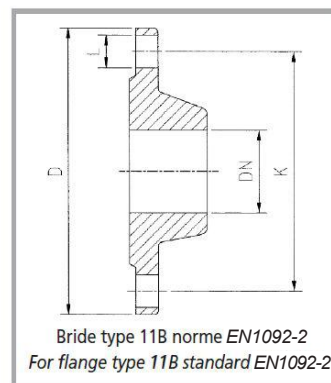



NOTICE D'INSTALLATION ET D'UTILISATION USE AND INSTALLATION NOTE



VANNE À PAPILLON
BUTTERFLY VALVE



Les vis en jaune
Screws in yellow



Les boulons en rouge
Bolts in red



Montage type 1
Avec ensemble boulons.
Assembling type 1
With bolts set.



Montage type 2
Avec vis.
Assembling type 2
With screws.

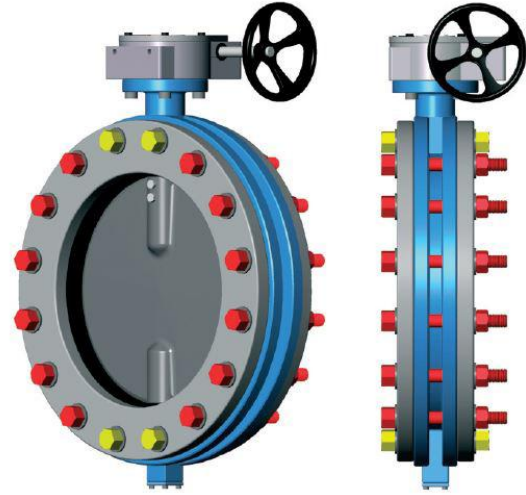

Montage type 3
Avec vis et ensemble boulons .
Assembling type 3
With screws and bolts set.

DIAMÈTRE INTÉRIEUR DES BRIDES / FLANGE INTERNAL DIAMETER

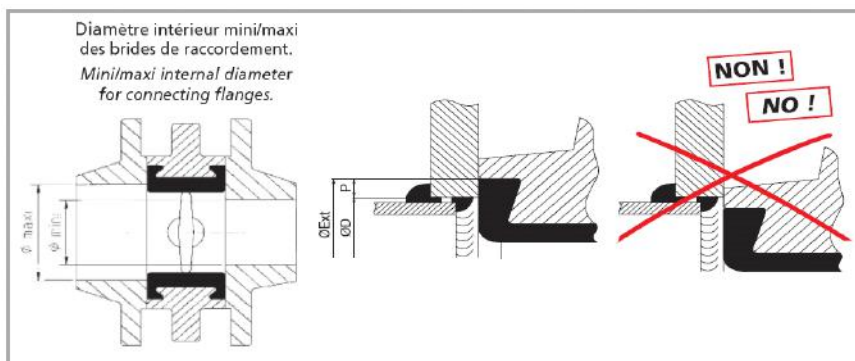

Fig.1

DN		Diamètre intérieur des brides Flange internal diameter	
mm	inch	mini	maxi
40	1" 1/2	25	50
50	2"	36	63
65	2" 1/2	50	78
80	3"	66	91
100	4"	92	116
125	5"	118	147
150	6"	143	171
200	8"	196	223
250	10"	246	277
300	12"	297	328
350	14"	324	359
400	16"	376	412
450	18"	425	462
500	20"	475	514
600	24"	572	630
700	28"	675	722
800	32"	772	842
900	36"	841	925
1000	40"	941	1025
1200	48"	1170	1235

NOTICE D'INSTALLATION ET D'UTILISATION USE AND INSTALLATION NOTE



Laisser suffisamment de place entre les deux brides pour pouvoir introduire le robinet sans endommager la manchette.

Leave enough space between the two flanges to allow valve installation without damaging the sleeve.

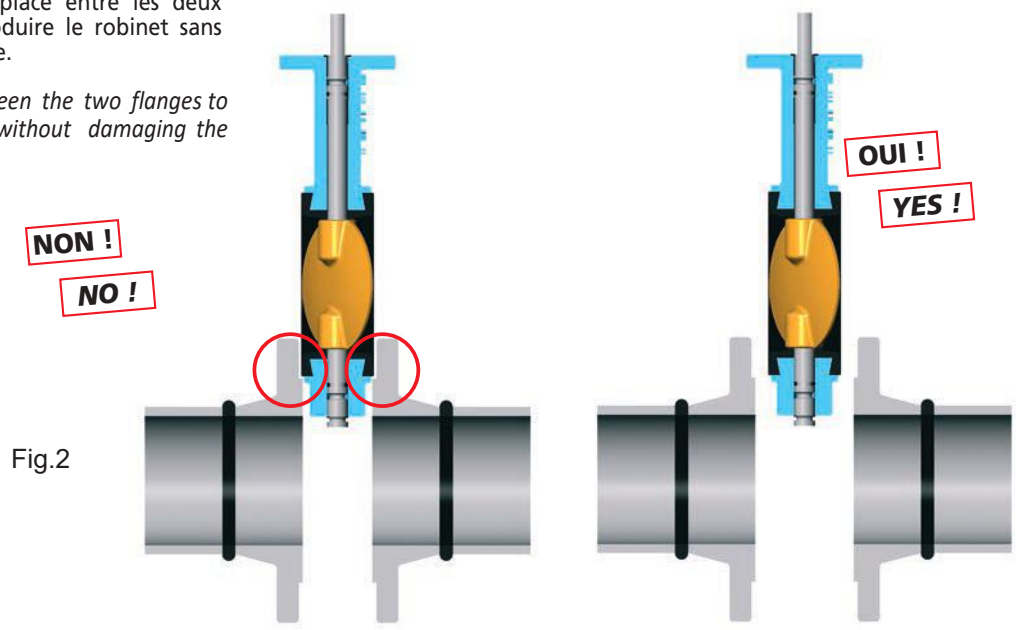

Fig.2

Ne pas monter le robinet à papillon en position fermée. La manchette risque d'être déformée provoquant serrage, blocage et fuite.

Do not assemble the butterfly valve in closed position to avoid sleeve deformation causing high tightening, sticking and leakage.

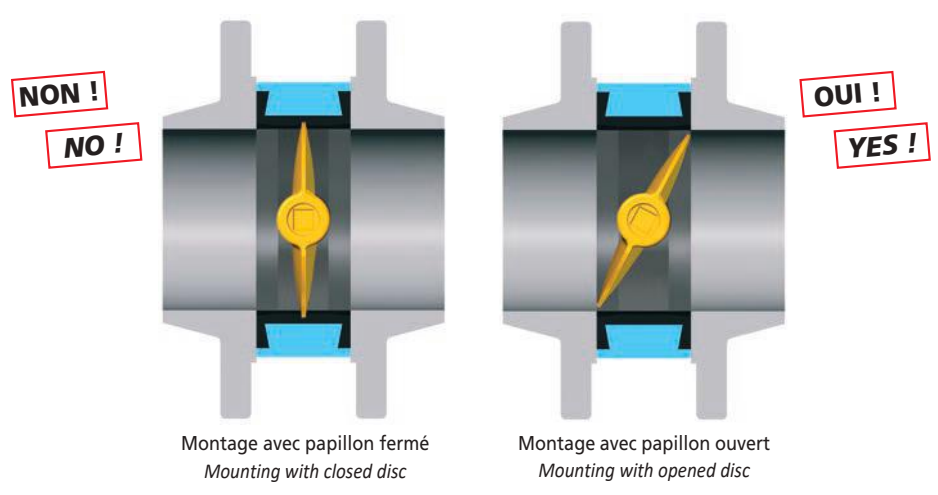

Fig.3

Des brides non conformes peuvent bloquer le papillon et/ou créer des turbulences dans la canalisation.

Unsuitable flanges can jam the disc and/or create turbulence in the pipe.

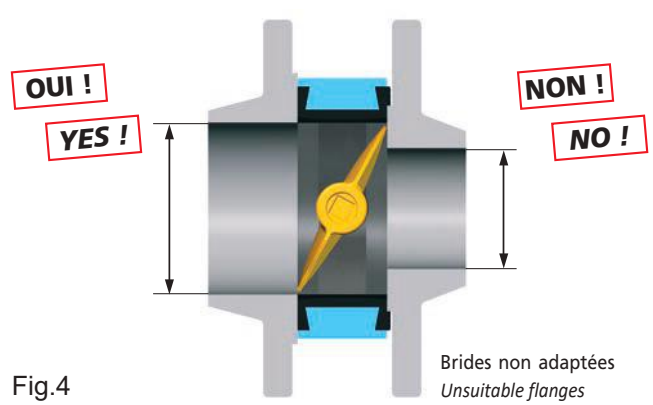
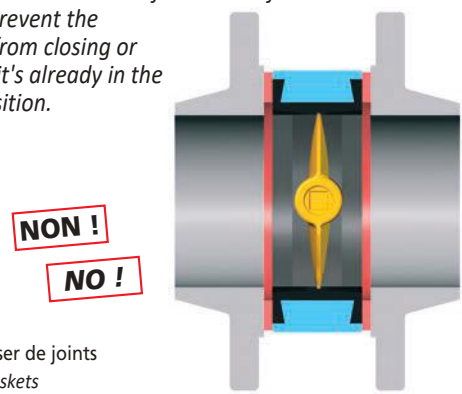

Fig.4

La pose d'un joint entre la bride et la manchette entraîne une déformation excessive de cette dernière. Cela a pour effet d'empêcher la fermeture du papillon ou de le bloquer s'il est déjà en position fermée.

The installation of a gasket between the flange and the sleeve results in an excessive deformation of the sleeve. This can prevent the butterfly from closing or block it if it's already in the closed position.



Ne pas utiliser de joints
Don't use gaskets

Fig.5



Installation
La vanne à papillon doit être installée dans une position qui permette de fermer la vanne à l'aide d'un levier ou d'une manivelle.

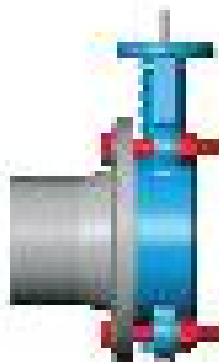

Utilisation
La vanne à papillon doit être utilisée dans une position qui permette de fermer la vanne à l'aide d'un levier ou d'une manivelle.



F

Attention
La vanne à papillon doit être utilisée dans une position qui permette de fermer la vanne à l'aide d'un levier ou d'une manivelle.

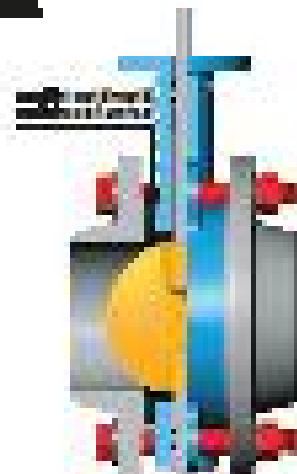

Installation
La vanne à papillon doit être installée dans une position qui permette de fermer la vanne à l'aide d'un levier ou d'une manivelle.

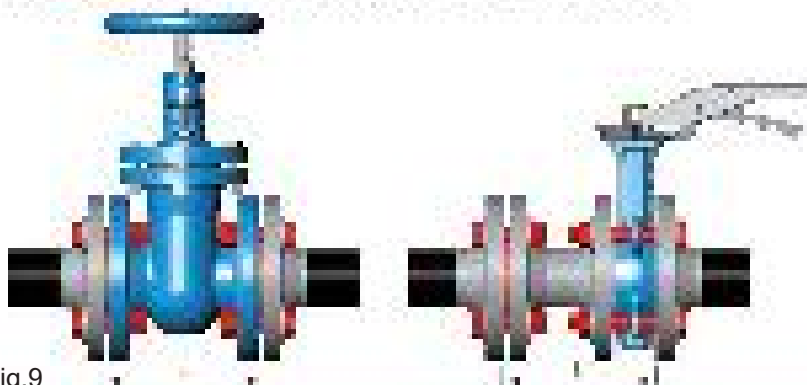
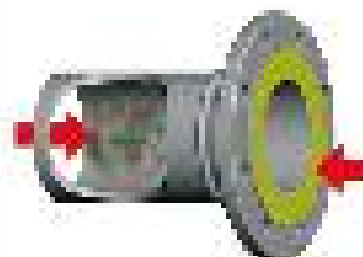

Fig.9

Utilisation
La vanne à papillon doit être utilisée dans une position qui permette de fermer la vanne à l'aide d'un levier ou d'une manivelle.



Attention
La vanne à papillon doit être utilisée dans une position qui permette de fermer la vanne à l'aide d'un levier ou d'une manivelle.

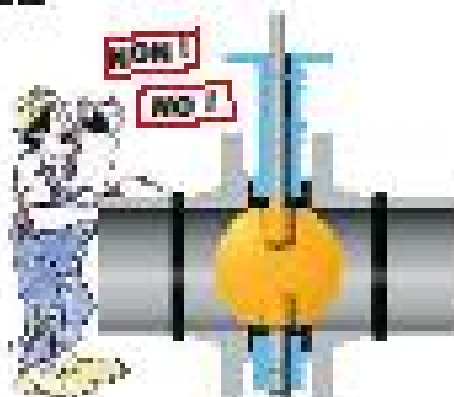
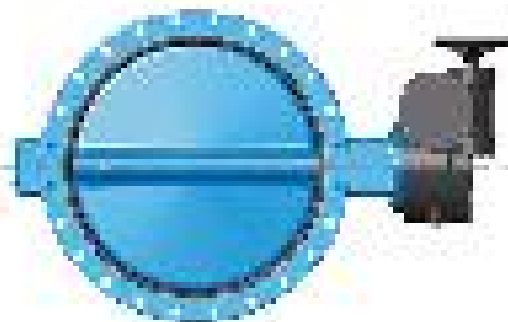

Fig.11

Installation
La vanne à papillon doit être installée dans une position qui permette de fermer la vanne à l'aide d'un levier ou d'une manivelle.



Attention
La vanne à papillon doit être utilisée dans une position qui permette de fermer la vanne à l'aide d'un levier ou d'une manivelle.

Fig.12

La vanne à guillotine notre ADN

Knife gate valve, our DNA



**Tecofi est le leader
mondial de la
fabrication de
vannes à guillotine**

Tecofi is the world leader
in knife gate valves



VANNE À GUILLOTINE

KNIFE GATE VALVE

NEW

FONTE DUCTILE
DUCTILE IRON

97 > 104

FIN DE GAMME
END OF RANGE

FONTE GRISE
CAST IRON

105 > 109

INOX
STAINLESS STEEL

110 > 117

VGB
BI-DIRECTIONNELLE
BIDIRECTIONAL

118 > 119

VGT
PELLE TRAVERSANTE
THROUGH TYPE

120

VGS
SOUS SILO
UNDER SILO

121

MANCHON / HAUTE
PRESSION | PINCH &
HIGH PRESSURE 122

KIT POUR VG
KIT FOR KGV

123 > 144

VANNE MURALE
PENSTOCK VALVE

146 > 151

CONSEILS TECHNIQUES
TECHNICAL NOTES

152 > 159

VANNE À GUILLOTINE

KNIFE GATE VALVE | DN 50-1200 - PN10

FOURREAU DE PROTECTION DE TIGE

Tige inox
Stem protection tube
Stainless steel rising-stem valve



GRAISSEUR INOX

Stainless steel greaser

PLAQUES-SUPPORT PRÉFORMÉES

Pre-shaped parts

PRÉPERÇAGE

Pour montage d'accessoires
Pilot hole for mounting accessories

BOULONNERIE INOX A2

A2 Stainless steel bolts

NEW

CORPS MONOBLOC FONTE DUCTILE

Évite les fuites
Fonte GGG50 grande résistance aux déformations et à l'abrasion.
Peinture époxy cuite au four mini 150µm.
GGG50 Ductile Iron one piece body
Prevents leakage.
Strong resistance to deformations and abrasions.
150 micron oven backed epoxy.

VOLANT FONTE GRISE INCASSABLE

Unbreakable cast iron handwheel

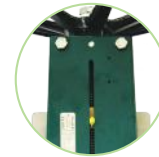

INDICATEUR DE POSITION

(option)
Position indicator



FOULOIR DE PRESSE ÉTOUPE BOULONNÉ AVEC ECROU NYLSTOP

Resserrable en service, pas de desserrage possible si vibration
Bolted packing gland
Retightening possible while in operation, untightening not possible in the case of vibrations

PELLE TRANCHANTE

Usinée et polie
Beveled gate
Machined and polished

JOINT MOULÉ ÉLASTOMÈRE ET PROFILÉ A TALON

Arrachement du siège impossible
Gasket seat wrenching not possible
Heel-shaped molded rubber gasket

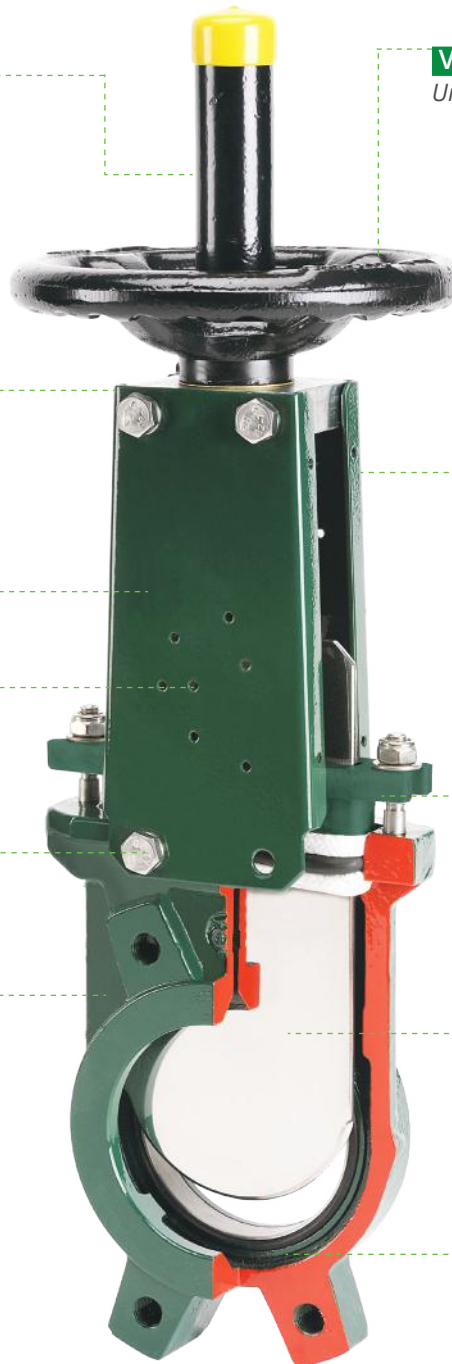

VANNES À GUILLOTINE

Les vannes à guillotine TECOFI sont particulièrement adaptées pour les applications les plus difficiles (traitement d'eau, papeterie, biogaz, vinicole, cimenterie, usines chimiques). Constituée d'une pelle chanfreinée coupante, la vanne à guillotine permet la pénétration dans le produit sans blocage. Le fouloir de presse étoupe en fonte ductile est très résistant, et la garniture de presse étoupe offre élasticité à l'ensemble et permet de réduire les efforts de manœuvre. TECOFI propose de nombreuses options pour répondre à toutes les contraintes des utilisateurs (contacts fin de course, capots de protection, traitement de pelle spécifique...)

KNIFE GATE VALVES

TECOFI knife gate valve are particularly suitable for the most difficult applications (water treatment networks, the pulp and paper industry, biogas, winemaking, cement works, chemical plants). The gate is sharp thanks to its beveled edge, facilitating the gate to cut the product without any blockage. The very resistant ductile iron packing gland and the material of the gasket offer more elasticity to the assembly, reducing the operating force. TECOFI offers many options to meet all user needs (mechanical limit switches, inductive sensor protection, specifically treated gate, etc.)



VANNE A GUILLOTINE STANDARD - FONTE DUCTILE
STANDARD KNIFE GATE VALVE - DUCTILE IRON



VANNE À GUILLOTINE
KNIFE GATE VALVE



ÉVOLUTION DE GAMME !

Corps fonte ductile standardisé

TECOFI adapte sa gamme aux contraintes mécaniques subies par ses vannes et vous propose désormais toutes les vannes à guillotine avec un **corps en fonte ductile (GS)**, parfaitement adapté aux industries lourdes (cimenterie, traitement de déchets...).

Robuste, la fonte ductile possède des propriétés mécaniques améliorées lui procurant une meilleure résistance aux chocs ainsi qu'une meilleure tenue aux vibrations et à l'abrasion.

**EN COURS DE CHANGEMENT !
COMING SOON!**

UPDATED RANGE!

Standard Ductile Iron Body

TECOFI is adapting its range to meet the mechanical strains its valves face, offering from now on all knife gate valves with **ductile iron** bodies, perfectly suitable for heavy industries (cement factories, waste treatment, etc.). Robust, ductile iron has improved mechanical properties, which permits better impact, vibration and abrasion resistance.

VG4400-00NI | VG4400-00MM | VG4400-00EA

Tige montante | Rising-stem

Vanne à guillotine fonte ductile à tige montante et à volant
 Ductile iron rising-stem knife gate valve with handwheel



**En cours de changement
Coming soon!**

Corps : Fonte ductile EN-GJS-500-7 (GGG50)
 Pelle : Inox 304
 Presse Etoupe : 2 tresses PTFE + 1 torique NBR
 Raccordement : Entre-brides PN10
 Pression de service :
 DN50-250 : 10 bar
 DN300-450 : 7 bar
 DN500-600 : 4 bar
 Température de service : -10°C/+ 80°C
 Plaques support acier préformées permettant l'adaptation d'accessoires

Body: Ductile iron EN-GJS-500-7 (GGG50)
 Gate: Stainless steel 304
 Packing: 2 PTFE packing + 1 NBR O-ring
 Connection: Between flanges PN10
 Working pressure:
 DN50-250: 10 bar
 DN300-450: 7 bar
 DN500-600: 4 bar
 Working temperature: -10°C/+ 80°C
 Pre-shaped parts for accessories

Réducteur conseillé > DN450
 Gearbox is recommended > DN450

				Etanchéité : Nitrile Seat: Nitrile	Etanchéité : Métal/Métal Seat: Metal/Metal
DN		L (mm)	Kg	Ref.	Ref.
mm	inch				
50	2"	40	7,5	VG4400-00NI0050	VG4400-00MM0050
65	2 1/2"	40	9	VG4400-00NI0065	VG4400-00MM0065
80	3"	50	10	VG4400-00NI0080	VG4400-00MM0080
100	4"	50	11,5	VG4400-00NI0100	VG4400-00MM0100
125	5"	50	15,5	VG4400-00NI0125	VG4400-00MM0125
150	6"	60	18,5	VG4400-00NI0150	VG4400-00MM0150
200	8"	60	35	VG4400-00NI0200	VG4400-00MM0200
250	10"	70	47	VG4400-00NI0250	VG4400-00MM0250
300	12"	70	61	VG4400-00NI0300	VG4400-00MM0300
350	14"	96	117	VG4400-00NI0350	VG4400-00MM0350
400	16"	100	151	VG4400-00NI0400	VG4400-00MM0400
450	18"	106	187	VG4400-00NI0450	VG4400-00MM0450
500	20"	110	205	VG4400-00NI0500	VG4400-00MM0500
600	24"	110	292	VG4400-00NI0600	VG4400-00MM0600



ATEX sur demande
ATEX on request



Optez pour la version ACS, pour vos applications sur eau potable !

Order ACS version for your drinking water applications!



Corps : Fonte ductile EN-GJS-500-7 (GGG50)
 Pelle : Inox 316L
 Peinture corps : Bleu ACS RAL5015
 Joint : EPDM ACS
 Tresse : PTFE compatible eau potable
 Raccordement : Entre-brides PN10
 Pression de service :
 DN50-250 : 10 bar
 DN300-450 : 7 bar
 DN500-600 : 4 bar
 Température de service : -10°C/+ 80°C
 Plaques support acier préformées permettant l'adaptation d'accessoires

Body: Ductile iron EN-GJS-500-7 (GGG50)
 Gate: Stainless Steel 316L
 Body coating: Blue ACS RAL5015
 Seal: EPDM ACS
 Packing: PTFE suitable potable water
 Connection: Between flanges PN10
 Working pressure:
 DN50-250: 10 bar
 DN300-450: 7 bar
 DN500-600: 4 bar
 Working temperature: -10°C/+ 80°C
 Pre-shaped parts for accessories

				EPDM ACS	
DN		L (mm)	Kg	Ref.	
mm	inch				
50	2"	40	7,5	VG4400-00EA0050	
65	2 1/2"	40	9	VG4400-00EA0065	
80	3"	50	10	VG4400-00EA0080	
100	4"	50	11,5	VG4400-00EA0100	
125	5"	50	15,5	VG4400-00EA0125	
150	6"	60	18,5	VG4400-00EA0150	
200	8"	60	35	VG4400-00EA0200	
250	10"	70	47	VG4400-00EA0250	
300	12"	70	61	VG4400-00EA0300	
350	14"	96	117	VG4400-00EA0350	
400	16"	100	151	VG4400-00EA0400	
450	18"	106	187	VG4400-00EA0450	
500	20"	110	205	VG4400-00EA0500	
600	24"	110	292	VG4400-00EA0600	





Ductile Iron body

VGA4430-00EP

ASA150 Tige montante | Rising-stem

Vanne à guillotine fonte ductile à tige montante et à volant- ASA 150
Ductile iron rising-stem knife gate valve with handwheel - ASA 150



En cours de changement
Coming soon!

Corps : Fonte ductile EN-GJS-500-7 (GGG50)
Pelle : Inox 304
Siège : EPDM
Presse Etoupe : 2 tresses PTFE + 1 torique EPDM
Raccordement : ASA150
Pression de service :
DN50-250 : 10 bar
DN300-450 : 7 bar
DN500-600 : 4 bar
Température de service : -10°C/+130°C

Body: Ductile iron EN-GJS-500-7 (GGG50)
Gate: Stainless steel 304

Seat: EPDM
Packing: 2 PTFE packing + 1 EPDM O-ring

Connection: ASA150

Working pressure:
DN50-250: 10 bar
DN300-450: 7 bar
DN500-600: 4 bar
Maximum Working temperature: -10°C/+130°C



Ex ATEX sur demande
ATEX on request

DN		L (mm)	Kg	Etanchéité : EPDM Seat: EPDM
mm	inch			
50	2"	40	7,5	VGA4430-00EP0050
65	2"1/2	40	9	VGA4430-00EP0065
80	3"	50	10	VGA4430-00EP0080
100	4"	50	11,5	VGA4430-00EP0100
125	5"	50	15,5	VGA4430-00EP0125
150	6"	60	18,5	VGA4430-00EP0150
200	8"	60	35	VGA4430-00EP0200
250	10"	70	47	VGA4430-00EP0250
300	12"	70	61	VGA4430-00EP0300
350	14"	96	117	VGA4430-00EP0350
400	16"	100	151	VGA4430-00EP0400
450	18"	106	187	VGA4430-00EP0450
500	20"	110	205	VGA4430-00EP0500
600	24"	110	292	VGA4430-00EP0600

Autre type de siège sur demande
Other seat type on request



Voir kit cadenassable page 123
See locking kit on page 123





Ductile Iron body

VG4400-001NI | VG4400-001MM | VG4400-001EA

Tige non montante | Non-rising stem

Vanne à guillotine fonte ductile à tige non montante et à volant
Ductile iron non-rising stem knife gate valve with handwheel



Encombrement optimisé en hauteur
Height-optimized dimensions



En cours de changement
Coming soon!

Corps : Fonte ductile EN-GJS-500-7 (GGG50)
Pelle : Inox 304
Presse Etoupe : 2 tresses PTFE + 1 torique NBR
Raccordement : Entre-brides PN10
Pression de service :
DN50-250 : 10 bar
DN300-450 : 7 bar
DN500-600 : 4 bar
Température de service : -10°C/+80°C
Plaques support acier préformées permettant l'adaptation d'accessoires

Body: Ductile Iron EN-GJS-500-7 (GGG50)
Gate: Stainless steel 304
Packing: 2 PTFE packing + 1 NBR O-ring
Connection: Between flanges PN10
Working pressure:
DN50-250: 10 bar
DN300-450: 7 bar
DN500-600: 4 bar
Working temperature: -10°C/+80°C
Pre-shaped parts for accessories



ATEX sur demande
ATEX on request

DN		L (mm)	Kg	Etanchéité : Nitrile Seat: Nitrile	Etanchéité : Métal/Métal Seat: Metal/Metal
mm	inch			Ref.	Ref.
50	2"	40	7,5	VG4400-001NI0050	VG4400-001MM0050
65	2 1/2"	40	8,8	VG4400-001NI0065	VG4400-001MM0065
80	3"	50	9,4	VG4400-001NI0080	VG4400-001MM0080
100	4"	50	11,5	VG4400-001NI0100	VG4400-001MM0100
125	5"	50	15,4	VG4400-001NI0125	VG4400-001MM0125
150	6"	60	18,5	VG4400-001NI0150	VG4400-001MM0150
200	8"	60	34,8	VG4400-001NI0200	VG4400-001MM0200
250	10"	70	47	VG4400-001NI0250	VG4400-001MM0250
300	12"	70	61	VG4400-001NI0300	VG4400-001MM0300
350	14"	96	117	VG4400-001NI0350	VG4400-001MM0350
400	16"	100	151	VG4400-001NI0400	VG4400-001MM0400
450	18"	106	187	VG4400-001NI0450	VG4400-001MM0450
500	20"	110	205	VG4400-001NI0500	VG4400-001MM0500
600	24"	110	292	VG4400-001NI0600	VG4400-001MM0600



Optez pour la version ACS, pour vos applications sur eau potable!

Order ACS version for your drinking water applications!



Corps : Fonte ductile EN-GJS-500-7 (GGG50)
Pelle : Inox 316L
Peinture corps : Bleu ACS RAL5015
Joint : EPDM ACS
Tresse : PTFE compatible eau potable
Raccordement : Entre-brides PN10
Pression de service :
DN50-250 : 10 bar
DN300-450 : 7 bar
DN500-600 : 4 bar
Température de service : -10°C/+80°C
Plaques support acier préformées permettant l'adaptation d'accessoires

Body: Ductile iron EN-GJS-500-7 (GGG50)
Gate: Stainless steel 316L
Body coating: Blue ACS RAL5015
Seal: EPDM ACS
Packing: PTFE suitable potable water
Connection: Between flanges PN10
Working pressure:
DN50-250: 10 bar
DN300-450: 7 bar
DN500-600: 4 bar
Working temperature: -10°C/+80°C
Pre-shaped parts for accessories

DN		L (mm)	Kg	EPDM ACS
mm	inch			Ref.
50	2"	40	7,5	VG4400-001EA0050
65	2 1/2"	40	8,8	VG4400-001EA0065
80	3"	50	9,4	VG4400-001EA0080
100	4"	50	11,5	VG4400-001EA0100
125	5"	50	15,4	VG4400-001EA0125
150	6"	60	18,5	VG4400-001EA0150
200	8"	60	34,8	VG4400-001EA0200
250	10"	70	47	VG4400-001EA0250
300	12"	70	61	VG4400-001EA0300
350	14"	96	117	VG4400-001EA0350
400	16"	100	151	VG4400-001EA0400
450	18"	106	187	VG4400-001EA0450
500	20"	110	205	VG4400-001EA0500
600	24"	110	292	VG4400-001EA0600





Ductile Iron body

VG4400-051NI | VG4400-051MM

Commande par carré de manœuvre | Square operating

Vanne à guillotine fonte ductile tige non montante et à carré de manœuvre
Ductile iron non-rising stem knife gate valve with square operating



En cours de changement
Coming soon!



Corps : Fonte ductile EN-GJS-500-7 (GGG50)
Pelle : Inox 304
Presse Etoupe : 2 tresses PTFE + 1 torique NBR
Raccordement : Entre-brides PN10
Pression de service :
DN50-250 : 10 bar
DN300-450 : 7 bar
DN500 : 4 bar
Température de service : -10°C/+80°C

Body: Ductile Iron EN-GJS-500-7 (GGG50)
Gate: Stainless steel 304
Packing: 2 PTFE packing + 1 NBR O-ring
Connection: Between flanges PN10
Working pressure:
DN50-250: 10 bar
DN300-450: 7 bar
DN500: 4 bar
Working temperature: -10°C/+80°C

DN				Etanchéité : Nitrile Seat: Nitrile		Etanchéité : Métal/Métal Seat: Metal/Metal	
mm	inch	L (mm)	Kg	Ref.	Ref.	Ref.	Ref.
50	2"	40	6,5	VG4400-051NI0050		VG4400-051MM0050	
65	2 1/2"	40	7,8	VG4400-051NI0065		VG4400-051MM0065	
80	3"	50	8,4	VG4400-051NI0080		VG4400-051MM0080	
100	4"	50	10,5	VG4400-051NI0100		VG4400-051MM0100	
125	5"	50	14,4	VG4400-051NI0125		VG4400-051MM0125	
150	6"	60	17,5	VG4400-051NI0150		VG4400-051MM0150	
200	8"	60	32,8	VG4400-051NI0200		VG4400-051MM0200	
250	10"	70	45	VG4400-051NI0250		VG4400-051MM0250	
300	12"	70	59	VG4400-051NI0300		VG4400-051MM0300	
350	14"	96	114	VG4400-051NI0350		VG4400-051MM0350	
400	16"	100	148	VG4400-051NI0400		VG4400-051MM0400	
450*	18"	106	184	VG4400-051NI0450		VG4400-051MM0450	

*Manœuvre manuelle non recommandée à partir du DN450
Manual operation not recommended from DN450 and up



ATEX sur demande
ATEX on request



Vanne idéale pour montage avec colonnette droite et murale ou installées dans un regard.
Voir pages 141-142
Valve ideal for column or wall mounting or installed in a manhole. See on pages 141-142



Voir carré seul page 123
See ref square page 123



VG4400-02NI | VG4400-02MM

Commande par levier | Lever operating

Vanne à guillotine fonte ductile à levier
Ductile iron knife gate valve lever operating



Ouverture et fermeture rapide
For quick opening and closing



En cours de changement
Coming soon!

Corps : Fonte ductile EN-GJS-500-7 (GGG50)
Pelle : Inox 304
Presse Etoupe : 2 tresses PTFE + 1 torique NBR
Raccordement : Entre-brides PN10
Pression de service :
DN50-250 : 10 bar
DN300 : 7 bar
Température de service : -10°C/+80°C
Actionnement de manœuvre rapide par levier

Body: Ductile Iron EN-GJS-500-7 (GGG50)
Gate: Stainless steel 304
Packing: 2 PTFE packing + 1 NBR O-ring
Connection: Between flanges PN10
Working pressure:
DN50-250: 10 bar
DN300: 7 bar
Working temperature: -10°C/+80°C
Fast lever actuation

DN				Etanchéité : Nitrile Seat: Nitrile		Etanchéité : Métal/Métal Seat: Metal/Metal	
mm	inch	L (mm)	Kg	Ref.	Ref.	Ref.	Ref.
50	2"	40	7,5	VG4400-02NI0050		VG4400-02MM0050	
65	2 1/2"	40	7,8	VG4400-02NI0065		VG4400-02MM0065	
80	3"	50	8,4	VG4400-02NI0080		VG4400-02MM0080	
100	4"	50	11,5	VG4400-02NI0100		VG4400-02MM0100	
125	5"	50	14,4	VG4400-02NI0125		VG4400-02MM0125	
150	6"	60	18,5	VG4400-02NI0150		VG4400-02MM0150	
200	8"	60	28,8	VG4400-02NI0200		VG4400-02MM0200	
250*	10"	70	41	VG4400-02NI0250		VG4400-02MM0250	
300*	12"	70	58	VG4400-02NI0300		VG4400-02MM0300	

*Manœuvre plus difficile à partir du DN250 | Please note: more difficult to operate from DN250 and up



ATEX sur demande
ATEX on request



Version (ACS) disponible sur demande
ACS model available on request



Voir kit cadennassable page 123
See locking kit page 123





Ductile Iron body

VG4400-03NI | VG4400-03MM | VG4400-03EA

Vérin pneumatique | Pneumatic actuator

Vanne à guillotine fonte ductile à vérin pneumatique double effet
Ductile iron knife gate valve with double-acting pneumatic actuator



En cours de changement
Coming soon!

Corps : Fonte ductile EN-GJS-500-7 (GGG50)
Pelle : Inox 304
Presse Etoupe : DN50-600 = 2 tresses PTFE+ 1 torique NBR
DN700-800 = 3 tresses PTFE+ 1 torique NBR
DN900-1200 = 4 tresses PTFE+ 1 torique NBR
Raccordement : Entre-bridés PN10
Pression de service :
DN50-250 : 10 bar
DN300-450 : 7 bar
DN500-600 : 4 bar
DN700-1200 : 2 bar
Température de service : -10°C/+80°C
Capots de protection : Inox 304
Vérin pneumatique double effet 6 bar

Body : Ductile iron EN-GJS-500-7 (GGG50)
Gate : Stainless steel 304
Packing : DN50-600 = 2 PTFE packing + 1 NBR O-ring
DN700-800 = 3 PTFE packing + 1 NBR O-ring
DN900-1200 = 4 PTFE packing + 1 NBR O-ring
Connection : Between flanges PN10

Working pressure :
DN50-250: 10 bar
DN300-450: 7 bar
DN500-600: 4 bar
DN700-1200: 2 bar
Working temperature : -10°C/+80°C
Protective cover : Stainless steel 304
Double-acting pneumatic actuator 6 bar



ATEX sur demande
ATEX on request



Utiliser de l'air comprimé conforme à la classe de pureté ISO 8573-1
Use compressed air conforming to the purity class ISO 8573-1

				Etanchéité : Nitrile Seat: Nitrile		Etanchéité : Métal/Métal Seat: Metal/Metal	
DN		L (mm)	Kg	Ref.		Ref.	
mm	inch						
50	2"	40	7,5	VG4400-03NI0050	VG4400-03MM0050		
65	2 1/2"	40	7,8	VG4400-03NI0065	VG4400-03MM0065		
80	3"	50	8,4	VG4400-03NI0080	VG4400-03MM0080		
100	4"	50	12,5	VG4400-03NI0100	VG4400-03MM0100		
125	5"	50	16,4	VG4400-03NI0125	VG4400-03MM0125		
150	6"	60	20,5	VG4400-03NI0150	VG4400-03MM0150		
200	8"	60	35,8	VG4400-03NI0200	VG4400-03MM0200		
250	10"	70	52	VG4400-03NI0250	VG4400-03MM0250		
300	12"	70	72	VG4400-03NI0300	VG4400-03MM0300		
350	14"	96	129	VG4400-03NI0350	VG4400-03MM0350		
400	16"	100	144	VG4400-03NI0400	VG4400-03MM0400		
450	18"	106	177	VG4400-03NI0450	VG4400-03MM0450		
500	20"	110	268	VG4400-03NI0500	VG4400-03MM0500		
600	24"	110	351	VG4400-03NI0600	VG4400-03MM0600		
700	28"	110	556	VG4400-03NI0700	VG4400-03MM0700		
800	32"	110	679	VG4400-03NI0800	VG4400-03MM0800		
900	36"	110	804	VG4400-03NI0900	VG4400-03MM0900		
1000	40"	120	1053	VG4400-03NI1000	VG4400-03MM1000		
1200	40"	130	-	VG4400-03NI1200	VG4400-03MM1200		

Version avec vérin pneumatique simple effet voir page 108
Version equipped with single-acting pneumatic actuator, see on page 108



Optez pour la version ACS, pour vos applications sur eau potable!

Order ACS version for your drinking water applications!



Corps : Fonte ductile EN-GJS-500-7 (GGG50)
Pelle : Inox 316L
Peinture corps : Bleu ACS RAL5015
Joint : EPDM ACS
Tresse : PTFE compatible eau potable
Raccordement : Entre-bridés PN10
Pression de service :
DN50-250 : 10 bar
DN300-450 : 7 bar
DN500-600 : 4 bar
DN700-1200 : 2 bar
Température de service : -10°C/+80°C
Capots de protection : Inox 304
Vérin pneumatique double effet 6 bar

Body : Ductile iron EN-GJS-500-7 (GGG50)
Gate : Stainless steel 316L
Body coating : Blue ACS RAL5015
Seal : EPDM ACS
Packing : PTFE suitable potable water
Connection : Between flanges PN10
Working pressure :
DN50-250: 10 bar
DN300-450: 7 bar
DN500-600: 4 bar
DN700-1200: 2 bar
Working temperature : -10°C/+80°C
Protective cover : Stainless steel 304
Double-acting pneumatic actuator 6 bar

				EPDM ACS	
DN		L (mm)	Kg	Ref.	
mm	inch				
50	2"	40	7,5	VG4400-03EA0050	
65	2 1/2"	40	7,8	VG4400-03EA0065	
80	3"	50	8,4	VG4400-03EA0080	
100	4"	50	12,5	VG4400-03EA0100	
125	5"	50	16,4	VG4400-03EA0125	
150	6"	60	20,5	VG4400-03EA0150	
200	8"	60	35,8	VG4400-03EA0200	
250	10"	70	52	VG4400-03EA0250	
300	12"	70	72	VG4400-03EA0300	
350	14"	96	129	VG4400-03EA0350	
400	16"	100	144	VG4400-03EA0400	
450	18"	106	177	VG4400-03EA0450	
500	20"	110	268	VG4400-03EA0500	
600	24"	110	351	VG4400-03EA0600	



Ductile Iron body

VGA4430-03EP

ASA150 Vérin pneumatique | Pneumatic actuator

Vanne à guillotine fonte ductile à vérin pneumatique double effet - ASA 150
Ductile iron knife gate valve with double-acting pneumatic actuator - ASA 150



En cours de changement
Coming soon!

Corps : Fonte ductile EN-GJS-500-7 (GGG50)
Pelle : Inox 304
Siège : EPDM
Presse Etoupe : 2 tresses PTFE + 1 torique NBR
Raccordement : ASA150
Pression de service :
DN50-250 : 10 bar
DN300-450 : 7 bar
Température de service : -10°C/+130°C
Capots de protection : Inox 304

Body: Ductile Iron EN-GJS-500-7 (GGG50)
Gate: Stainless steel 304
Seat: EPDM
Packing: 2 PTFE packing + 1 NBR O-ring
Connection: ASA150
Working pressure:
DN50-250: 10 bar
DN300-450: 7 bar
Working temperature: -10°C/+130°C
Protective cover: Stainless steel 304



ATEX sur demande
ATEX on request



Utiliser de l'air comprimé conforme à la classe de pureté ISO 8573-1
Use compressed air conforming to the purity class ISO 8573-1

DN		L (mm)	Kg	Etanchéité : EPDM Seat: EPDM.
mm	inch			
50	2"	40	7,5	VGA4430-03EP0050
65	2"1/2	40	7,8	VGA4430-03EP0065
80	3"	50	8,4	VGA4430-03EP0080
100	4"	50	12,5	VGA4430-03EP0100
125	5"	50	16,4	VGA4430-03EP0125
150	6"	60	20,5	VGA4430-03EP0150
200	8"	60	35,8	VGA4430-03EP0200
250	10"	70	52	VGA4430-03EP0250
300	12"	70	72	VGA4430-03EP0300
350	14"	96	129	VGA4430-03EP0350
400	16"	100	144	VGA4430-03EP0400
450	18"	106	177	VGA4430-03EP0450
500	20"	110	205	VGA4430-03EP500
600	24"	110	292	VGA4430-03EP600

Autre type de siège sur demande
Other seat type on request

VG4400-031NI

Commande de secours | Manual emergency control

Vanne à guillotine fonte ductile à vérin pneumatique double effet + commande manuelle de secours
Ductile iron knife gate valve with double-acting pneumatic actuator + manual emergency control



En cours de changement
Coming soon!

Corps : Fonte ductile EN-GJS-500-7 (GGG50)
Pelle : Inox 304
Presse Etoupe : 2 tresses PTFE + 1 torique NBR
Raccordement : Entre-brides PN10
Pression de service :
DN50-250 : 10 bar
DN300-450 : 7 bar
DN500-600 : 4 bar
Température de service : -10°C/+80°C
Capot de protection : Inox 304
Vérin pneumatique double effet 6 bar équipé de commande manuelle de secours

Body: Ductile Iron EN-GJS-500-7 (GGG50)
Gate: Stainless steel 304
Packing: 2 PTFE packing + 1 NBR O-ring
Connection: Between flanges PN10
Working pressure:
DN50-250: 10 bar
DN300-450: 7 bar
DN500-600: 4 bar
Working temperature: -10°C/+80°C
Protective cover: Stainless steel 304
Double-acting pneumatic actuator 6 bar equipped with manual emergency control



ATEX sur demande
ATEX on request



Utiliser de l'air comprimé conforme à la classe de pureté ISO 8573-1
Use compressed air conforming to the purity class ISO 8573-1

DN		L (mm)	Kg	Etanchéité : Nitrile Seat: Nitrile.
mm	inch			
50	2"	40	10	VG4400-031NI0050
65	2"1/2	40	11	VG4400-031NI0065
80	3"	50	12	VG4400-031NI0080
100	4"	50	15	VG4400-031NI0100
125	5"	50	21	VG4400-031NI0125
150	6"	60	27	VG4400-031NI0150
200	8"	60	45	VG4400-031NI0200
250	10"	70	69	VG4400-031NI0250
300	12"	70	89	VG4400-031NI0300
350	14"	96	153	VG4400-031NI0350
400	16"	100	166	VG4400-031NI0400
450	18"	106	212	VG4400-031NI0450
500	20"	110	251	VG4400-031NI0500
600	24"	110	300	VG4400-031NI0600



Voir kit de commande seul page 125
See control kit on page 125





Ductile Iron body

VG4400-004NI | VG4400-004MM **Embase ISO | ISO mounting plate**

Vanne à guillotine fonte ductile à tige montante avec embase ISO pour motorisation électrique
Ductile iron rising-stem knife gate valve with ISO mounting plate for electric actuator



En cours de changement
Coming soon!

Corps : Fonte ductile EN-GJS-500-7 (GGG50)
Pelle : Inox 304
Embase ISO : Acier A45
Presse Etoupe : 2 tresses PTFE + 1 torique NBR
Raccordement : Entre-bridés PN10
Pression de service :
DN50-250 : 10 bar
DN300-450 : 7 bar
DN500-600 : 4 bar
Température de service : -10°C/+80°C

Body: Ductile Iron EN-GJS-500-7 (GGG50)
Gate: Stainless steel 304
ISO plate : Steel A45
Packing: 2 PTFE packing + 1 NBR O-ring
Connection: Between flanges PN10
Working pressure:
DN50-250: 10 bar
DN300-450: 7 bar
DN500-600: 4 bar
Working temperature: -10°C/+80°C

DN				Kg	Etanchéité : Nitrile Seat: Nitrile	Etanchéité : Métal/Métal Seat: Metal/Metal
mm	inch	L (mm)	Ref.		Ref.	
50	2"	40	6	VG4400-004NI0050	VG4400-004MM0050	
65	2 1/2"	40	8	VG4400-004NI0065	VG4400-004MM0065	
80	3"	50	9	VG4400-004NI0080	VG4400-004MM0080	
100	4"	50	10	VG4400-004NI0100	VG4400-004MM0100	
125	5"	50	15	VG4400-004NI0125	VG4400-004MM0125	
150	6"	60	19	VG4400-004NI0150	VG4400-004MM0150	
200	8"	60	33	VG4400-004NI0200	VG4400-004MM0200	
250	10"	70	47	VG4400-004NI0250	VG4400-004MM0250	
300	12"	70	58	VG4400-004NI0300	VG4400-004MM0300	
350	14"	96	107	VG4400-004NI0350	VG4400-004MM0350	
400	16"	100	137	VG4400-004NI0400	VG4400-004MM0400	
450	18"	106	177	VG4400-004NI0450	VG4400-004MM0450	
500	20"	110	212	VG4400-004NI0500	VG4400-004MM0500	
600	24"	110	256	VG4400-004NI0600	VG4400-004MM0600	

Pour DN supérieur, voir vannes avec réducteur motorisable
Other DN, please check the valve stem gearbox actuator operating



ATEX sur demande
ATEX on request



Version (ACS) disponible sur demande
ACS model available on request

VG4400-08NI | VG4400-08MM **Réducteur manuel | Gearbox actuator**

Vanne à guillotine fonte ductile à tige montante à réducteur manuel
Ductile iron knife gate valve rising-stem with gearbox actuator operating



Avec platine de motorisation sur réducteur
With motorization plate on reducer

En cours de changement
Coming soon!

Corps : Fonte ductile EN-GJS-500-7 (GGG50)
Pelle : Inox 304
Presse Etoupe :
DN50-600 = 2 tresses PTFE+ 1 torique NBR
DN700-800 = 3 tresses PTFE+ 1 torique NBR
DN900-1200 = 4 tresses PTFE+ 1 torique NBR
Raccordement : Entre-bridés PN10
Pression de service :
DN350-450 : 7 bar
DN500-600 : 4 bar
DN700-1200 : 2 bar
Température de service : -10°C/+80°C
Manœuvre : Réducteur à volant ou motorisable

Body: Ductile iron EN-GJS-500-7 (GGG50)
Gate: Stainless steel 304
Packing:
DN50-600 = 2 PTFE packing + 1 NBR O-ring
DN700-800 = 3 PTFE packing + 1 NBR O-ring
DN900-1200 = 4 PTFE packing + 1 NBR O-ring
Connection: Between flanges PN10
Working pressure:
DN350-450: 7 bar
DN500-600: 4 bar
DN700-1200: 2 bar
Working temperature: -10°C/+80°C
Operation : Manual gearbox with handwheel or ISO top flange for electric actuator connection

DN				Kg	Réducteur manuel à volant Manual handwheel gearbox	
mm	inch	L (mm)	Etanchéité : Nitrile Seat: Nitrile		Etanchéité : Métal/Métal Seat: Metal/Metal	
				Ref.	Ref.	
350	14"	96	127	VG4400-08NI0350	VG4400-08MM0350	☺
400	16"	100	159	VG4400-08NI0400	VG4400-08MM0400	☺
450	18"	110	198	VG4400-08NI0450	VG4400-08MM0450	☺
500	20"	110	233	VG4400-08NI0500	VG4400-08MM0500	☺
600	24"	110	277	VG4400-08NI0600	VG4400-08MM0600	☺

DN				Kg	Réducteur motorisable Motorizable gearbox	
mm	inch	L (mm)	Etanchéité : Nitrile Seat: Nitrile		Etanchéité : Métal/Métal Seat: Metal/Metal	
				Ref.	Ref.	
700	28"	110	410	VG4400-08NI0700	VG4400-08MM0700	☺
800	32"	110	560	VG4400-08NI0800	VG4400-08MM0800	☺
900	36"	110	780	VG4400-08NI0900	VG4400-08MM0900	☺
1 000	40"	110	985	VG4400-08NI1000	VG4400-08MM1000	☺
1 200	48"	120	1635	VG4400-08NI1200	VG4400-08MM1200	☺



ATEX sur demande
ATEX on request



Version (ACS) disponible sur demande
ACS model available on request



Ductile Iron body

VG4400-U04NI

AUMA

Vanne à guillotine fonte ductile à tige montante avec moteur AUMA - entre brides PN10
Ductile iron rising-stem knife gate valve with AUMA electric actuator - between flanges PN10

En cours de changement
Coming soon!



Corps : Fonte ductile EN-GJS-500-7 (GGG50)
Pelle : Inox 304
Joint de siège : NBR
Presse Etoupe : DN50-600 = 2 tresses PTFE+ 1 torique NBR
DN700-800 = 3 tresses PTFE+ 1 torique NBR
DN900-1200 = 4 tresses PTFE+ 1 torique NBR
Raccordement : Entre-brides PN10
Pression de service :
DN50-250 : 10 bar
DN300-450 : 7 bar
DN500-600 : 4 bar
DN700-1200 : 2 bar
Température de service : -10°C / +80°C
Type de moteur : AUMA 400V 3PH
Équipé de capot de protection selon Directive Machine

Body: Ductile Iron EN-GJS-500-7 (GGG50)
Gate: Stainless steel 304
Seat gasket: NBR
Packing: DN50-600 = 2 PTFE packing + 1 NBR O-ring
DN700-800 = 3 PTFE packing + 1 NBR O-ring
DN900-1200 = 4 PTFE packing + 1 NBR O-ring
Connection: Between flanges PN10
Working pressure:
DN50-250: 10 bar
DN300-450: 7 bar
DN500-600: 4 bar
DN700-1200: 2 bar
Working temperature: -10°C/+80°C
Actuator type: AUMA 400V 3PH
Equipped with protective cover according to Machine Directive



ATEX sur demande
ATEX on request



Moteur monté sur réducteur motorisable
Actuator mounted on gearbox

DN		L (mm)	Kg	Etanchéité : Nitrile Seat: Nitrile
mm	inch			
50	2"	40	27	VG4400-U04NI0050
65	2 1/2"	40	29	VG4400-U04NI0065
80	3"	50	30	VG4400-U04NI0080
100	4"	50	31	VG4400-U04NI0100
125	5"	50	38	VG4400-U04NI0125
150	6"	60	42	VG4400-U04NI0150
200	8"	60	57	VG4400-U04NI0200
250	10"	70	75	VG4400-U04NI0250
300	12"	70	87	VG4400-U04NI0300
350	14"	96	137	VG4400-U04NI0350
400	16"	100	167	VG4400-U04NI0400
450	18"	106	231	VG4400-U04NI0450
500	20"	110	266	VG4400-U04NI0500
600	24"	110	310	VG4400-U04NI0600
700	28"	110	435	VG4400-U04NI0700
800	32"	110	585	VG4400-U04NI0800
900	36"	110	805	VG4400-U04NI0900
1 000	40"	110	1016	VG4400-U04NI1000
1 200	48"	120	1683	VG4400-U04NI1200



Version **(ACS)** disponible sur demande
ACS model available on request



Voir moteur AUMA seul page 125
See AUMA actuator on page 125

VGA4430-U04NI

ASA 150 AUMA

Vanne à guillotine fonte ductile à tige montante avec moteur AUMA - ASA 150
Ductile iron rising-stem knife gate valve with AUMA electric actuator - ASA 150

En cours de changement
Coming soon!



Corps : Fonte ductile EN-GJS-500-7 (GGG50)
Pelle : Inox 304
Joint de siège : NBR
Presse Etoupe : DN50-600 = 2 tresses PTFE+ 1 torique NBR
Raccordement : Entre-brides PN10
Pression de service :
DN50-250 : 10 bar
DN300-450 : 7 bar
DN500-600 : 4 bar
Température de service : -10°C / +80°C
Type de moteur : AUMA 400V 3PH
Équipé de capot de protection selon Directive Machine

Body: Ductile Iron EN-GJS-500-7 (GGG50)
Gate: Stainless steel 304
Seat gasket: NBR
Packing: DN50-600 = 2 PTFE packing + 1 NBR O-ring
Connection: Between flanges PN10
Working pressure:
DN50-250: 10 bar
DN300-450: 7 bar
DN500-600: 4 bar
Working temperature: -10°C/+80°C
Actuator type: AUMA 400V 3PH
Equipped with protective cover according to Machine Directive



ATEX sur demande
ATEX on request



DN		L (mm)	Kg	Etanchéité : Nitrile Seat: Nitrile
mm	inch			
50	2"	40	27	VGA4430-U04NI0050
65	2 1/2"	40	29	VGA4430-U04NI0065
80	3"	50	30	VGA4430-U04NI0080
100	4"	50	31	VGA4430-U04NI0100
125	5"	50	38	VGA4430-U04NI0125
150	6"	60	42	VGA4430-U04NI0150
200	8"	60	57	VGA4430-U04NI0200
250	10"	70	75	VGA4430-U04NI0250
300	12"	70	87	VGA4430-U04NI0300
350	14"	96	137	VGA4430-U04NI0350
400	16"	100	167	VGA4430-U04NI0400
450	18"	106	231	VGA4430-U04NI0450
500	20"	110	266	VGA4430-U04NI0500
600	24"	110	310	VGA4430-U04NI0600



Voir moteur AUMA seul page 125
See AUMA actuator on page 125



VANNE A GUILLOTINE STANDARD - FONTE GRISE
STANDARD KNIFE GATE VALVE - CAST IRON

JUSQU'À ÉPUISEMENT DES STOCKS
WHILE STOCKS LAST

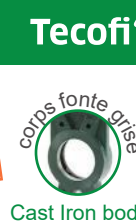

VANNE À GUILLOTINE
KNIFE GATE VALVE

VG3400-00NI | VG3400-00MM

Tige montante | Rising-stem

Vanne à guillotine fonte grise à tige montante et à volant
 Rising-stem cast iron knife gate valve with handwheel



JUSQU'À ÉPUISEMENT DES STOCKS
WHILE STOCKS LAST

Corps : Fonte EN-GJL-250 (GG25)
Pelle : Inox 304
Presse Etoupe :
 - 2 tresses PTFE
 - 1 torique NBR
Raccordement : Entre-brides PN10
Pression de service :
 DN50-250 : 10 bar
 DN300-450 : 7 bar
 DN500-600 : 4 bar
Température de service : -10°C/+ 80°C
 Plaques support acier préformées permettant l'adaptation d'accessoires

Body: Cast iron EN-GJL-250 (GG25)
Gate: Stainless steel 304
Packing:
 - 2 PTFE packing
 - 1 NBR O-ring
Connection: Between flanges PN10
Working pressure:
 DN50-250: 10 bar
 DN300-450: 7 bar
 DN500-600: 4 bar
Working temperature: -10°C/+ 80°C
 Pre-shaped parts for accessories



ATEX sur demande
ATEX on request

Réducteur conseillé
 > DN400
 Gearbox is
 recommended
 > DN400

DN		L (mm)	Kg	Etanchéité : Nitrile Seat: Nitrile	Etanchéité : Métal/Métal Seat: Metal/Metal
mm	inch			Ref.	Ref.
50	2"	40	7,5	VG3400-00NI0050	VG3400-00MM0050
65	2"1/2	40	9	VG3400-00NI0065	VG3400-00MM0065
80	3"	50	10	VG3400-00NI0080	VG3400-00MM0080
100	4"	50	11,5	VG3400-00NI0100	VG3400-00MM0100
125	5"	50	15,5	VG3400-00NI0125	VG3400-00MM0125
150	6"	60	18,5	VG3400-00NI0150	VG3400-00MM0150
200	8"	60	35	VG3400-00NI0200	VG3400-00MM0200
250	10"	70	47	VG3400-00NI0250	VG3400-00MM0250
300	12"	70	61	VG3400-00NI0300	VG3400-00MM0300
350	14"	96	117	VG3400-00NI0350	VG3400-00MM0350
400	16"	100	151	VG3400-00NI0400	VG3400-00MM0400
450	18"	106	187	VG3400-00NI0450	VG3400-00MM0450
500	20"	110	205	VG3400-00NI0500	VG3400-00MM0500
600	24"	110	292	VG3400-00NI0600	VG3400-00MM0600



Modèle (ACS) à volant pages 97 et 99
ACS type with handwheel on pages 97 and 99

VGA3430-00EP

ASA 150 Tige montante | Rising-stem

Vanne à guillotine fonte grise à tige montante et à volant - ASA 150
 Rising-stem cast iron knife gate valve with handwheel - ASA 150



JUSQU'À ÉPUISEMENT DES STOCKS
WHILE STOCKS LAST

Corps : Fonte EN-GJL-250 (GG25)
Pelle : Inox 304
Siège : EPDM
Presse Etoupe :
 - 2 tresses PTFE
 - 1 torique EPDM
Raccordement : ASA150
Pression de service :
 DN50-250 : 10 bar
 DN300-450 : 7 bar
 DN500-600 : 4 bar
Température de service : -10°C/+130°C

Body: Cast iron EN-GJL-250 (GG25)
Gate: Stainless steel 304
Seat: EPDM
Packing:
 - 2 PTFE packing
 - 1 EPDM O-ring
Connection: ASA150
Working pressure:
 DN50-250: 10 bar
 DN300-450: 7 bar
 DN500-600: 4 bar
Maximum working temperature: -10°C/+130°C

DN		L (mm)	Kg	Ref.
mm	inch			
50	2"	40	7,5	VGA3430-00EP0050
65	2"1/2	40	9	VGA3430-00EP0065
80	3"	50	10	VGA3430-00EP0080
100	4"	50	11,5	VGA3430-00EP0100
125	5"	50	15,5	VGA3430-00EP0125
150	6"	60	18,5	VGA3430-00EP0150
200	8"	60	35	VGA3430-00EP0200
250	10"	70	47	VGA3430-00EP0250
300	12"	70	61	VGA3430-00EP0300
350	14"	96	117	VGA3430-00EP0350
400	16"	100	151	VGA3430-00EP0400
450	18"	106	187	VGA3430-00EP0450
500	20"	110	205	VGA3430-00EP0500
600	24"	110	292	VGA3430-00EP0600



**JUSQU'À ÉPUISEMENT DES STOCKS
WHILE STOCKS LAST**

VANNE À GUILLOTINE
KNIFE GATE VALVE

VG3400-001NI | VG3400-001MM

Tige non montante | Non-rising stem

Vanne à guillotine fonte grise à tige non montante et à volant
Non-rising stem cast iron knife gate valve with handwheel



**Encombrement optimisé en hauteur
Optimized height**

**JUSQU'À ÉPUISEMENT DES STOCKS
WHILE STOCKS LAST**

Corps : Fonte EN-GJL-250 (GG25)
Pelle : Inox 304
Presse Etoupe :
- 2 tresses PTFE
- 1 torique NBR
Raccordement : Entre-brides PN10
Pression de service :
DN50-250 : 10 bar
DN300-450 : 7 bar
DN500-600 : 4 bar
Température de service : -10°C/+80°C
Plaques support acier préformées permettant l'adaptation d'accessoires

Body: Cast iron EN-GJL-250 (GG25)
Gate: Stainless steel 304
Packing:
- 2 PTFE packing
- 1 NBR O-ring
Connection: Between flanges PN10
Working pressure:
DN50-250: 10 bar
DN300-450: 7 bar
DN500-600: 4 bar
Working temperature: -10°C/+80°C
Pre-shaped parts for accessories

DN		L (mm)	Kg	Etanchéité : Nitrile Seat: Nitrile	Etanchéité : Métal/Métal Seat: Metal/Metal
mm	inch			Ref.	Ref.
50	2"	40	7,5	VG3400-001NI0050	VG3400-001MM0050
65	2"1/2	40	8,8	VG3400-001NI0065	VG3400-001MM0065
80	3"	50	9,4	VG3400-001NI0080	VG3400-001MM0080
100	4"	50	11,5	VG3400-001NI0100	VG3400-001MM0100
125	5"	50	15,4	VG3400-001NI0125	VG3400-001MM0125
150	6"	60	18,5	VG3400-001NI0150	VG3400-001MM0150
200	8"	60	34,8	VG3400-001NI0200	VG3400-001MM0200
250	10"	70	47	VG3400-001NI0250	VG3400-001MM0250
300	12"	70	61	VG3400-001NI0300	VG3400-001MM0300
350	14"	96	117	VG3400-001NI0350	VG3400-001MM0350
400	16"	100	151	VG3400-001NI0400	VG3400-001MM0400
450	18"	106	187	VG3400-001NI0450	VG3400-001MM0450
500	20"	110	205	VG3400-001NI0500	VG3400-001MM0500
600	24"	110	292	VG3400-001NI0600	VG3400-001MM0600



Ex ATEX sur demande
ATEX on request

**Modèle ACS à volant pages 97 et 99
ACS type with handwheel on pages 97 and 99**

VG3400-02NI | VG3400-02MM

Commande par levier | Lever operating

Vanne à guillotine fonte grise à levier
Cast iron knife gate valve with lever



**Ouverture et fermeture rapide
For quick opening and closing**

**JUSQU'À ÉPUISEMENT DES STOCKS
WHILE STOCKS LAST**

Corps : Fonte EN-GJL-250 (GG25)
Pelle : Inox 304
Presse Etoupe :
- 2 tresses PTFE
- 1 torique NBR
Raccordement : Entre-brides PN10
Pression de service :
DN50-250 : 10 bar
DN300 : 7 bar
Température de service : -10°C/+80°C
Actionnement de manœuvre rapide par levier

Body: Cast iron EN-GJL-250 (GG25)
Gate: Stainless steel 304
Packing:
- 2 PTFE packing
- 1 NBR O-ring
Connection: Between flanges PN10
Working pressure:
DN50-250: 10 bar
DN300: 7 bar
Working temperature: -10°C/+80°C
Fast lever actuation

DN		L (mm)	Kg	Etanchéité : Nitrile Seat: Nitrile	Etanchéité : Métal/Métal Seat: Metal/Metal
mm	inch			Ref.	Ref.
50	2"	40	7,5	VG3400-02NI0050	VG3400-02MM0050
65	2"1/2	40	7,8	VG3400-02NI0065	VG3400-02MM0065
80	3"	50	8,4	VG3400-02NI0080	VG3400-02MM0080
100	4"	50	11,5	VG3400-02NI0100	VG3400-02MM0100
125	5"	50	14,4	VG3400-02NI0125	VG3400-02MM0125
150	6"	60	18,5	VG3400-02NI0150	VG3400-02MM0150
200	8"	60	28,8	VG3400-02NI0200	VG3400-02MM0200
250*	10"	70	41	VG3400-02NI0250	VG3400-02MM0250
300*	12"	70	58	VG3400-02NI0300	VG3400-02MM0300

*Attention, manœuvre plus difficile à partir du DN250
Please note: more difficult to operate from DN250 and up



Ex ATEX sur demande
ATEX on request

**JUSQU'À ÉPUISEMENT DES STOCKS
WHILE STOCKS LAST**



VG3400-03NI | VG3400-03MM

Vérin pneumatique | Pneumatic actuator

Vanne à guillotine fonte grise à vérin pneumatique double effet
Cast iron knife gate valve with double-acting pneumatic actuator



**JUSQU'A ÉPUISEMENT DES STOCKS
WHILE STOCKS LAST**

Corps : Fonte EN-GJL-250 (GG25)
Pelle : Inox 304
Presse Etoupe :
- 2 tresses PTFE
- 1 torique NBR
Raccordement : Entre-brides PN10
Pression de service :
DN50-250 : 10 bar
DN300-450 : 7 bar
DN500-600 : 4 bar
DN700-1000 : 2 bar
Température de service : -10°C/+80°C
Capot de protection : Inox 304

Body: Cast iron EN-GJL-250 (GG25)
Gate: Stainless steel 304

Packing:
- 2 PTFE packing
- 1 NBR O-ring
Connection: Between flanges PN10

Working pressure:
DN50-250: 10 bar
DN300-450: 7 bar
DN500-600: 4 bar
DN700-1000: 2 bar
Working temperature: -10°C/+80°C
Rising-stem preshaped: Stainless steel 304



Ex ATEX sur demande
ATEX on request



Utiliser de l'air comprimé conforme à la classe de pureté ISO 8573-1
Use compressed air conforming to the purity class ISO 8573-1

DN		L (mm)	Kg	Etanchéité : Nitrile Seat: Nitrile	Etanchéité : Métal/Métal Seat: Metal/Metal
mm	inch			Ref.	Ref.
50	2"	40	7,5	VG3400-03NI0050	VG3400-03MM0050
65	2"1/2	40	7,8	VG3400-03NI0065	VG3400-03MM0065
80	3"	50	8,4	VG3400-03NI0080	VG3400-03MM0080
100	4"	50	12,5	VG3400-03NI0100	VG3400-03MM0100
125	5"	50	16,4	VG3400-03NI0125	VG3400-03MM0125
150	6"	60	20,5	VG3400-03NI0150	VG3400-03MM0150
200	8"	60	35,8	VG3400-03NI0200	VG3400-03MM0200
250	10"	70	52	VG3400-03NI0250	VG3400-03MM0250
300	12"	70	72	VG3400-03NI0300	VG3400-03MM0300
350	14"	96	129	VG3400-03NI0350	VG3400-03MM0350
400	16"	100	144	VG3400-03NI0400	VG3400-03MM0400
450	18"	106	177	VG3400-03NI0450	VG3400-03MM0450
500	20"	110	268	VG3400-03NI0500	VG3400-03MM0500
600	24"	110	351	VG3400-03NI0600	VG3400-03MM0600
700	28"	110	556	VG3400-03NI0700	VG3400-03MM0700
800	32"	110	679	VG3400-03NI0800	VG3400-03MM0800
900	36"	110	804	VG3400-03NI0900	VG3400-03MM0900
1000	40"	110	1053	VG3400-03NI1000	VG3400-03MM1000

Version avec vérin pneumatique simple effet voir page 108.
Version equipped with single-acting pneumatic actuator, see on page 108.

VGA3430-03EP

ASA150 Vérin pneumatique | Pneumatic actuator

Vanne à guillotine à vérin pneumatique double effet - ASA 150
Cast iron knife gate valve with double-acting pneumatic actuator - ASA 150



**JUSQU'A ÉPUISEMENT DES STOCKS
WHILE STOCKS LAST**

Corps : Fonte EN-GJL-250 (GG25)
Pelle : Inox 304
Siège : EPDM
Presse Etoupe :
- 2 tresses PTFE
- 1 torique NBR
Raccordement : ASA150
Pression de service :
DN50-250 : 10 bar
DN300-450 : 7 bar
Température de service : -10°C/+130°C

Body: Cast iron EN-GJL-250 (GG25)
Gate: Stainless steel 304

Seat: EPDM
Packing:
- 2 PTFE packing
- 1 NBR O-ring

Connection: ASA150
Working pressure:
DN50-250: 10 bar
DN300-450: 7 bar
Working temperature: -10°C/+130°C

DN		L (mm)	Kg	Ref.
mm	inch			
50	2"	40	7,5	VGA3430-03EP0050
65	2"1/2	40	7,8	VGA3430-03EP0065
80	3"	50	8,4	VGA3430-03EP0080
100	4"	50	12,5	VGA3430-03EP0100
125	5"	50	16,4	VGA3430-03EP0125
150	6"	60	20,5	VGA3430-03EP0150
200	8"	60	35,8	VGA3430-03EP0200
250	10"	70	52	VGA3430-03EP0250
300	12"	70	72	VGA3430-03EP0300
350	14"	96	129	VGA3430-03EP0350
400	16"	100	144	VGA3430-03EP0400
450	18"	106	177	VGA3430-03EP0450



Utiliser de l'air comprimé conforme à la classe de pureté ISO 8573-1
Use compressed air conforming to the purity class ISO 8573-1



Cast Iron body

VG3400-07NI | VG3400-07MM

Vérin pneumatique | Pneumatic actuator

Vanne à guillotine fonte grise à vérin pneumatique simple effet N.F*
Cast Iron knife gate valve with single-acting pneumatic actuator N.C*



Corps : Fonte EN-GJL-250 (GG25)
Pelle : Inox 304
Presse Etoupe :
- 2 tresses PTFE
- 1 torique NBR
Raccordement : Entre-bridés PN10
Pression de service :
DN50-150 : 10 bar
DN200 : 8 bar
DN250-300 : 6 bar
Température de service : -10°C/+80°C

Body: Cast iron EN-GJL-250 (GG25)

Gate: Stainless steel 304

Packing:

- 2 PTFE packing
- 1 NBR O-ring

Connection: Between flanges PN10

Working pressure:

DN50-150: 10 bar

DN200: 8 bar

DN250-300: 6 bar

Working temperature: -10°C/+80°C

DN		L (mm)	Kg	Etanchéité : Nitrile Seat: Nitrile	Etanchéité : Métal/Métal Seat: Metal/Metal
mm	inch			Ref.	Ref.
50	2"	40	19	VG3400-07NI0050	VG3400-07MM0050
65	2 1/2"	40	22	VG3400-07NI0065	VG3400-07MM0065
80	3"	50	23	VG3400-07NI0080	VG3400-07MM0080
100	4"	50	24	VG3400-07NI0100	VG3400-07MM0100
125	5"	50	35	VG3400-07NI0125	VG3400-07MM0125
150	6"	60	36	VG3400-07NI0150	VG3400-07MM0150
200	8"	60	66	VG3400-07NI0200	VG3400-07MM0200
250	10"	70	130	VG3400-07NI0250	VG3400-07MM0250
300	12"	70	143	VG3400-07NI0300	VG3400-07MM0300

*N.O sur demande / N.O on request



ATEX sur demande
ATEX on request



Utiliser de l'air comprimé conforme à la classe de pureté ISO 8573-1
Use compressed air conforming to the purity class ISO 8573-1



Au delà du DN300, prévoir VG double effet avec ballon réserve de secours d'air comprimé.
Beyond DN300, provide double-acting KGV with emergency compressed air tank.



**JUSQU'À ÉPUISEMENT DES STOCKS
WHILE STOCKS LAST**



VANNE À GUILLOTINE
KNIFE GATE VALVE

VG3400-004NI | VG3400-004MM

Embase ISO | ISO mounting plate

Vanne à guillotine fonte grise à tige montante avec embase ISO pour motorisation électrique
Rising-stem cast iron knife gate valve with ISO mounting plate for electric actuator



**JUSQU'À ÉPUISEMENT DES STOCKS
WHILE STOCKS LAST**

Corps : Fonte EN-GJL-250 (GG25)
Pelle : Inox 304
Presse Etoupe :
- 2 tresses PTFE
- 1 torique NBR
Raccordement : Entre-brides PN10
Pression de service :
DN50-250 : 10 bar
DN300-450 : 7 bar
DN500-600 : 4 bar
Température de service : -10°C/+80°C

Body: Cast iron EN-GJL-250 (GG25)
Gate: Stainless steel 304
Packing:
- 2 PTFE packing
- 1 NBR O-ring
Connection: Between flanges PN10
Working pressure:
DN50-250: 10 bar
DN300-450: 7 bar
DN500-600: 4 bar
Working temperature: -10°C/+80°C



Ex ATEX sur demande
ATEX on request

DN				Kg	Etanchéité : Nitrile Seat: Nitrile	Etanchéité : Métal/Métal Seat: Metal/Metal
mm	inch	L (mm)	Ref.		Ref.	
50	2"	40	6	VG3400-004NI0050	VG3400-004MM0050	
65	2 1/2"	40	8	VG3400-004NI0065	VG3400-004MM0065	
80	3"	50	9	VG3400-004NI0080	VG3400-004MM0080	
100	4"	50	10	VG3400-004NI0100	VG3400-004MM0100	
125	5"	50	15	VG3400-004NI0125	VG3400-004MM0125	
150	6"	60	19	VG3400-004NI0150	VG3400-004MM0150	
200	8"	60	33	VG3400-004NI0200	VG3400-004MM0200	
250	10"	70	47	VG3400-004NI0250	VG3400-004MM0250	
300	12"	70	58	VG3400-004NI0300	VG3400-004MM0300	
350	14"	96	107	VG3400-004NI0350	VG3400-004MM0350	
400	16"	100	137	VG3400-004NI0400	VG3400-004MM0400	
450	18"	106	177	VG3400-004NI0450	VG3400-004MM0450	
500	20"	110	212	VG3400-004NI0500	VG3400-004MM0500	
600	24"	110	256	VG3400-004NI0600	VG3400-004MM0600	

**Avec embase de motorisation et tige de manœuvre rallongée pour accouplement.
With baseplate for motorization and extended operating stem for coupling.**

VG3400-08NI | VG3400-08MM

Réducteur | Gearbox actuator

Vanne à guillotine fonte grise à tige montante à réducteur
Stainless steel rising-stem gearbox actuator operating cast iron knife gate valve



**JUSQU'À ÉPUISEMENT DES STOCKS
WHILE STOCKS LAST**

Corps : Fonte EN-GJL-250 (GG25)
Pelle : Inox 304
Presse Etoupe :
- 2 tresses PTFE
- 1 torique NBR
Raccordement : Entre-brides PN10
Pression de service :
DN300-450 : 7 bar
DN500-600 : 4 bar
DN700-1200 : 2 bar
Température de service : -10°C/+80°C
Manoeuvre : Réducteur à volant ou motorisable

Body: Cast iron EN-GJL-250 (GG25)
Gate: Stainless steel 304
Packing:
- 2 PTFE packing
- 1 NBR O-ring
Connection: Between flanges PN10
Working pressure:
DN 300-450: 7 bar
DN500-600: 4 bar
DN700-1200: 2 bar
Working temperature: -10°C/+80°C
Operation : Manual gearbox with handwheel or ISO top flange for electric actuator connection

Avec platine de motorisation sur réducteur
With motorization plate on reducer



Ex ATEX sur demande
ATEX on request

				Réducteur manuel à volant Manual handwheel gearbox	
				Etanchéité : Nitrile Seat: Nitrile	Etanchéité : Métal/Métal Seat: Metal/Metal
				Ref.	Ref.
DN					
mm	inch	L (mm)	Kg		
350	14"	100	127	VG3400-08NI0350	VG3400-08MM0350
400	16"	100	159	VG3400-08NI0400	VG3400-08MM0400
450	18"	110	198	VG3400-08NI0450	VG3400-08MM0450
500	20"	110	233	VG3400-08NI0500	VG3400-08MM0500
600	24"	110	277	VG3400-08NI0600	VG3400-08MM0600

				Réducteur motorisable Motorizable gearbox	
				Etanchéité : Nitrile Seat: Nitrile	Etanchéité : Métal/Métal Seat: Metal/Metal
				Ref.	Ref.
DN					
mm	inch	L (mm)	Kg		
700	28"	110	410	VG3400-08NI0700	VG3400-08MM0700
800	32"	110	560	VG3400-08NI0800	VG3400-08MM0800
900	36"	110	780	VG3400-08NI0900	VG3400-08MM0900
1 000	40"	110	985	VG3400-08NI1000	VG3400-08MM1000
1 200	48"	120	1635	VG3400-08NI1200	VG3400-08MM1200



VANNE A GUILLOTINE - INOX
KNIFE GATE VALVE - STAINLESS STEEL



Stainless steel body

VG6400-00EP | VG6400-00MM | VG6400-00EA

Tige montante | Rising-stem

Vanne à guillotine à volant tige montante
Rising-stem cast iron knife gate valve with handwheel



Corps : Inox 316 (CF8M)
Pelle : Inox 316L
Presse Etoupe : 2 tresses PTFE + 1 torique EPDM
Raccordement : Entre-brides PN10
Pression de service :
DN50-250 : 10 bar
DN300-450 : 7 bar
DN500-600 : 4 bar
Température de service : -10°/+130°C

Body: Stainless steel 316 (CF8M)
Gate: Stainless steel 316L
Packing: 2 PTFE packing + 1 EPDM O-ring
Connection: Between flanges PN10
Working pressure:
DN50-250: 10 bar
DN300-450: 7 bar
DN500-600: 4 bar
Maximum working temperature:
-10°/+130°C

Réducteur conseillé
> DN400
Gearbox is
recommended
> DN400

DN				Kg	Etanchéité : EPDM Seat: EPDM	Etanchéité : Métal/Métal Seat: Metal/Metal
mm	inch	L (mm)	Ref.		Ref.	
50	2"	40	7,5		VG6400-00EP0050	VG6400-00MM0050
65	2 1/2"	40	9		VG6400-00EP0065	VG6400-00MM0065
80	3"	50	10		VG6400-00EP0080	VG6400-00MM0080
100	4"	50	11,5		VG6400-00EP0100	VG6400-00MM0100
125	5"	50	15,5		VG6400-00EP0125	VG6400-00MM0125
150	6"	60	18,5		VG6400-00EP0150	VG6400-00MM0150
200	8"	60	35		VG6400-00EP0200	VG6400-00MM0200
250	10"	70	47		VG6400-00EP0250	VG6400-00MM0250
300	12"	70	61		VG6400-00EP0300	VG6400-00MM0300
350	14"	96	117		VG6400-00EP0350	VG6400-00MM0350
400	16"	100	151		VG6400-00EP0400	VG6400-00MM0400
450	18"	106	187		VG6400-00EP0450	VG6400-00MM0450
500	20"	110	205		VG6400-00EP0500	VG6400-00MM0500
600	24"	110	292		VG6400-00EP0600	VG6400-00MM0600



ATEX sur demande
ATEX on request

Plaques supports Inox 304 et 316 page 132 pour une vanne tout inox !
Support plates SS 304 and 316 on page 132 for a Stainless steel valve!



Optez pour la version ACS, pour vos applications sur eau potable !

Order ACS version for your drinking water applications!

ACS



Corps : Inox 316 (CF8M)
Pelle : Inox 316L
Joint : EPDM ACS
Tresse : PTFE compatible eau potable
Raccordement : Entre-brides PN10
Pression de service :
DN50-250 : 10 bar
DN300-450 : 7 bar
DN500-600 : 4 bar
Température de service : -10°C/+ 80°C

Body: Stainless steel 316 (CF8M)
Gate: Stainless steel 316L
Seal: EPDM ACS
Packing: PTFE suitable for potable water
Connection: Between flanges PN10
Working pressure:
DN50-250: 10 bar
DN300-450: 7 bar
DN500-600: 4 bar
Working temperature: -10°C/+ 80°C



DN				Kg	EPDM ACS
mm	inch	L (mm)	Ref.		
50	2"	40	7,5		VG6400-00EA0050
65	2 1/2"	40	9		VG6400-00EA0065
80	3"	50	10		VG6400-00EA0080
100	4"	50	11,5		VG6400-00EA0100
125	5"	50	15,5		VG6400-00EA0125
150	6"	60	18,5		VG6400-00EA0150
200	8"	60	35		VG6400-00EA0200
250	10"	70	47		VG6400-00EA0250
300	12"	70	61		VG6400-00EA0300
350	14"	96	117		VG6400-00EA0350
400	16"	100	151		VG6400-00EA0400
450	18"	106	187		VG6400-00EA0450
500	20"	110	205		VG6400-00EA0500
600	24"	110	292		VG6400-00EA0600





Stainless steel body

VGA6430-00EP | VGA6430-00MM

ASA 150 Tige montante | Rising-stem

Vanne à guillotine à volant tige montante - ASA 150
Rising-stem knife gate valve with handwheel - ASA 150



Corps : Inox 316 (CF8M)
Pelle : Inox 316L
Presse Etoupe : 2 tresses PTFE + 1 torique EPDM
Raccordement : ASA 150
Pression de service :
DN50-250 : 10 bar
DN300-450 : 7 bar
DN500-600 : 4 bar
Température de service : -10°/130°C

Body: Stainless steel 316 (CF8M)
Gate: Stainless steel 316L
Packing: 2 PTFE packing + 1 EPDM O-ring
Connection: ASA 150
Working pressure:
DN50-250: 10 bar
DN300-450: 7 bar
DN500-600: 4 bar
Working temperature:
-10°/130°C

Réducteur conseillé
> DN400
Gearbox is
recommended
> DN400

DN				Kg	Etanchéité : EPDM Seat: EPDM	Etanchéité : Métal/Métal Seat: Metal/Metal
mm	inch	L (mm)	Ref.		Ref.	
50	2"	40	7,5	VGA6430-00EP0050	VGA6430-00MM0050	
65	2 1/2"	40	9	VGA6430-00EP0065	VGA6430-00MM0065	
80	3"	50	10	VGA6430-00EP0080	VGA6430-00MM0080	
100	4"	50	11,5	VGA6430-00EP0100	VGA6430-00MM0100	
125	5"	50	15,5	VGA6430-00EP0125	VGA6430-00MM0125	
150	6"	60	18,5	VGA6430-00EP0150	VGA6430-00MM0150	
200	8"	60	35	VGA6430-00EP0200	VGA6430-00MM0200	
250	10"	70	47	VGA6430-00EP0250	VGA6430-00MM0250	
300	12"	70	61	VGA6430-00EP0300	VGA6430-00MM0300	
350	14"	96	117	VGA6430-00EP0350	VGA6430-00MM0350	
400	16"	100	151	VGA6430-00EP0400	VGA6430-00MM0400	
450	18"	106	187	VGA6430-00EP0450	VGA6430-00MM0450	
500	20"	110	205	VGA6430-00EP0500	VGA6430-00MM0500	
600	24"	110	292	VGA6400-00EP0600	VGA6400-00MM0600	

Autre type de siège sur demande
Other seat type on request



Plaques supports Inox 304 et 316 page 132 pour une vanne tout inox !
Support plates SS 304 and 316 on page 132 for a Stainless steel valves!



Voir kit cadenassable page 123
See locking kit on page 123





Stainless steel body

VG6400-001EP | VG6400-001MM | VG6400-001EA

Tige non montante | Non-rising stem

Vanne à guillotine à volant tige non montante
Non-rising stem knife gate valve with handwheel



Encombrement optimisé en hauteur
Optimized height



Corps : Inox 316 (CF8M)
Pelle : Inox 316L
Presse Etoupe : 2 tresses PTFE + 1 torique EPDM
Raccordement : Entre-bridés PN10
Pression de service :
DN50-250 : 10 bar
DN300-450 : 7 bar
DN500-600 : 4 bar
Température de service : -10°/130°C

Body: Stainless steel 316 (CF8M)
Gate: Stainless steel 316L
Packing: 2 PTFE packing + 1 EPDM O-ring
Connection: Between flanges PN10
Working pressure:
DN50-250: 10 bar
DN300-450: 7 bar
DN500-600: 4 bar
Working temperature: -10°/130°C



ATEX sur demande
ATEX on request

DN		L (mm)	Kg	Etanchéité : EPDM Seat: EPDM	Etanchéité : Métal/Métal Seat: Metal/Metal
mm	inch			Ref.	Ref.
50	2"	40	7,5	VG6400-001EP0050	VG6400-001MM0050
65	2 1/2"	40	8,8	VG6400-001EP0065	VG6400-001MM0065
80	3"	50	9,4	VG6400-001EP0080	VG6400-001MM0080
100	4"	50	11,5	VG6400-001EP0100	VG6400-001MM0100
125	5"	50	15,4	VG6400-001EP0125	VG6400-001MM0125
150	6"	60	18,5	VG6400-001EP0150	VG6400-001MM0150
200	8"	60	34,8	VG6400-001EP0200	VG6400-001MM0200
250	10"	70	47	VG6400-001EP0250	VG6400-001MM0250
300	12"	70	61	VG6400-001EP0300	VG6400-001MM0300
350	14"	96	117	VG6400-001EP0350	VG6400-001MM0350
400	16"	100	151	VG6400-001EP0400	VG6400-001MM0400
450	18"	106	187	VG6400-001EP0450	VG6400-001MM0450
500	20"	110	205	VG6400-001EP0500	VG6400-001MM0500
600	24"	110	292	VG6400-001EP0600	VG6400-001MM0600



Optez pour la version ACS, pour vos applications sur eau potable !

Order ACS version for your drinking water applications!

ACS



Corps : Inox 316 (CF8M)
Pelle : Inox 316L
Joint : EPDM ACS
Tresse : PTFE compatible eau potable
Raccordement : Entre-bridés PN10
Pression de service :
DN50-250 : 10 bar
DN300-450 : 7 bar
DN500-600 : 4 bar
Température de service : -10°C/+ 80°C

Body: Stainless steel 316 (CF8M)
Gate: Stainless steel 316L
Seal: EPDM ACS
Packing: PTFE suitable potable water
Connection: Between flanges PN10
Working pressure:
DN50-250: 10 bar
DN300-450: 7 bar
DN500-600: 4 bar
Working temperature: -10°C/+ 80°C

NEW

DN		L (mm)	Kg	EPDM ACS
mm	inch			Ref.
50	2"	40	7,5	VG6400-001EA0050
65	2 1/2"	40	8,8	VG6400-001EA0065
80	3"	50	9,4	VG6400-001EA0080
100	4"	50	11,5	VG6400-001EA0100
125	5"	50	15,4	VG6400-001EA0125
150	6"	60	18,5	VG6400-001EA0150
200	8"	60	34,8	VG6400-001EA0200
250	10"	70	47	VG6400-001EA0250
300	12"	70	61	VG6400-001EA0300
350	14"	96	117	VG6400-001EA0350
400	16"	100	151	VG6400-001EA0400
450	18"	106	187	VG6400-001EA0450
500	20"	110	205	VG6400-001EA0500
600	24"	110	292	VG6400-001EA0600



corps inox



Stainless steel body

VG6400-051EP | VG6400-051MM

Commande par carré de manoeuvre | Square operating

Vanne à guillotine à tige non montante et à carré de manoeuvre
Non-rising stem knife gate valve with square operating



Corps : Inox 316 (CF8M)
Pelle : Inox 316L
Presse Etope :
- 2 tresses PTFE
- 1 torique EPDM
Raccordement : Entre-brides PN10
Pression de service :
DN50-250 : 10 bar
DN300-400 : 7 bar
DN500 : 4 bar
Température de service : -10°C/+130°C

Body: Stainless steel 316 (CF8M)
Gate: Stainless steel 316L

Packing:
- 2 PTFE packing
- 1 EPDM O-ring
Connection: Between flanges PN10

Working pressure:
DN50-250: 10 bar
DN300-400: 7 bar
DN500: 4 bar
Working temperature: -10°C+130°C



DN				Kg	Etanchéité : EPDM Seat: EPDM	Etanchéité : Métal/Métal Seat: Metal/Metal
mm	inch	L (mm)	Ref.		Ref.	
50	2"	40	6	VG6400-051EP0050	VG6400-051MM0050	
65	2 1/2"	40	7,8	VG6400-051EP0065	VG6400-051MM0065	
80	3"	50	8,4	VG6400-051EP0080	VG6400-051MM0080	
100	4"	50	10,5	VG6400-051EP0100	VG6400-051MM0100	
125	5"	50	14,4	VG6400-051EP0125	VG6400-051MM0125	
150	6"	60	17,5	VG6400-051EP0150	VG6400-051MM0150	
200	8"	60	32,8	VG6400-051EP0200	VG6400-051MM0200	
250	10"	70	45	VG6400-051EP0250	VG6400-051MM0250	
300	12"	70	59	VG6400-051EP0300	VG6400-051MM0300	
350	14"	96	114	VG6400-051EP0350	VG6400-051MM0350	
400	16"	100	148	VG6400-051EP0400	VG6400-051MM0400	
450*	18"	106	186	VG6400-051EP0450	VG6400-051MM0450	
500*	20"	110	221	VG6400-051EP0500	VG6400-051MM0500	
600*	24"	110	305	VG6400-051EP0600	VG6400-051MM0600	

*Manœuvre manuelle non recommandée à partir du DN450
Manual operation not recommended from DN450



ATEX sur demande
ATEX on request



Vanne idéale pour montage avec colonnette droite et murale ou installée dans un regard. Voir pages 141-142
Valve adapted for pedestal floor and wall mounted. See on pages 141-142



Voir carré seul page 123
See ref square on page 123



VG6400-02EP | VG6400-02MM

Commande par levier | Lever operating

Vanne à guillotine à levier
Knife gate valve lever operating



Pour ouverture et fermeture rapide
For quick opening and closing



Corps : Inox 316 (CF8M)
Pelle : Inox 316L
Presse Etope :
- 2 tresses PTFE
- 1 torique EPDM
Raccordement : Entre-brides PN10
Pression de service :
DN50-250 : 10 bar
DN300 : 7 bar
Température de service : -10°/130°C
Actionnement de manoeuvre rapide par levier

Body: Stainless steel 316 (CF8M)
Gate: Stainless steel 316L

Packing:
- 2 PTFE packing
- 1 EPDM O-ring
Connection: Between flanges PN10

Working pressure:
DN50-250: 10 bar
DN300: 7 bar
Maximum Working temperature: -10°/130°C
Fast lever actuation

DN				Kg	Etanchéité : EPDM Seat: EPDM	Etanchéité : Métal/Métal Seat: Metal/Metal
mm	inch	L (mm)	Ref.		Ref.	
50	2"	40	7,5	VG6400-02EP0050	VG6400-02MM0050	
65	2 1/2"	40	7,8	VG6400-02EP0065	VG6400-02MM0065	
80	3"	50	8,4	VG6400-02EP0080	VG6400-02MM0080	
100	4"	50	11,5	VG6400-02EP0100	VG6400-02MM0100	
125	5"	50	14,4	VG6400-02EP0125	VG6400-02MM0125	
150	6"	60	18,5	VG6400-02EP0150	VG6400-02MM0150	
200	8"	60	28,8	VG6400-02EP0200	VG6400-02MM0200	
250*	10"	70	41	VG6400-02EP0250	VG6400-02MM0250	
300*	12"	70	58	VG6400-02EP0300	VG6400-02MM0300	

*Attention, manoeuvre plus difficile à partir du DN250
Please note: more difficult to operate from DN250 and up



ATEX sur demande
ATEX on request



Version (ACS) disponible sur demande
ACS model available on request



Voir kit cadenassable page 123
See locking kit on page 123





Stainless steel body

VG6400-03EP | VG6400-03MM | VG6400-03EA

Vérin pneumatique | Pneumatic actuator

Vanne à guillotine à vérin pneumatique double effet
Knife gate valve with double-acting pneumatic actuator



Corps : Inox 316 (CF8M)
Pelle : Inox 316L
Presse Etoupe :
DN50-600 = 2 tresses PTFE+ 1 torique EPDM
DN700-800 = 3 tresses PTFE+ 1 torique EPDM
DN900-1200 = 4 tresses PTFE+ 1 torique EPDM
Raccordement : Entre-brides PN10
Pression de service :
DN50-250 : 10 bar
DN300-450 : 7 bar
DN500-600 : 4 bar
DN700-1200 : 2 bar
Température de service : -10°/130°C
Capot de protection : Inox 304
Vérin pneumatique double effet 6 bar

Body: Stainless steel 316 (CF8M)
Gate: Stainless steel 316L
Packing: DN50-600 = 2 PTFE packing + 1 EPDM O-ring
DN700-800 = 3 PTFE packing + 1 EPDM O-ring
DN900-1200 = 4 PTFE packing + 1 EPDM O-ring
Connection: Between flanges PN10
Working pressure:
DN50-250: 10 bar
DN300-450: 7 bar
DN500-600: 4 bar
DN700-1200: 2 bar
Maximum Working temperature: -10°/130°C
Protective cover: Stainless steel 304
Double-acting pneumatic actuator 6 bar

DN				Kg	Etanchéité : EPDM Seat: EPDM	Etanchéité : Métal/Métal Seat: Metal/Metal
mm	inch	L (mm)	Ref.		Ref.	
50	2"	40	7,5	VG6400-03EP0050	VG6400-03MM0050	
65	2 1/2"	40	7,8	VG6400-03EP0065	VG6400-03MM0065	
80	3"	50	8,4	VG6400-03EP0080	VG6400-03MM0080	
100	4"	50	12,5	VG6400-03EP0100	VG6400-03MM0100	
125	5"	50	16,4	VG6400-03EP0125	VG6400-03MM0125	
150	6"	60	20,5	VG6400-03EP0150	VG6400-03MM0150	
200	8"	60	35,8	VG6400-03EP0200	VG6400-03MM0200	
250	10"	70	52	VG6400-03EP0250	VG6400-03MM0250	
300	12"	70	72	VG6400-03EP0300	VG6400-03MM0300	
350	14"	96	129	VG6400-03EP0350	VG6400-03MM0350	
400	16"	100	144	VG6400-03EP0400	VG6400-03MM0400	
450	18"	106	177	VG6400-03EP0450	VG6400-03MM0450	
500	20"	110	268	VG6400-03EP0500	VG6400-03MM0500	
600	24"	110	351	VG6400-03EP0600	VG6400-03MM0600	
700	28"	110	556	VG6400-03EP0700	VG6400-03MM0700	
800	32"	110	679	VG6400-03EP0800	VG6400-03MM0800	
900	36"	110	840	VG6400-03EP0900	VG6400-03MM0900	
1 000	40"	110	1053	VG6400-03EP1000	VG6400-03MM1000	
1 200	48"	120	-	VG6400-03EP1200	VG6400-03MM1200	

Version avec vérin pneumatique simple effet voir page 115
Version equipped with single-acting pneumatic actuator, see page 115



ATEX sur demande
ATEX on request



Optez pour la version ACS, pour vos applications sur eau potable!

Order ACS version for your drinking water applications!

ACS



Joint : EPDM ACS
Tresse : PTFE compatible eau potable
Température de service : -10°C/+ 80°C
Seal: EPDM ACS
Packing: PTFE suitable potable water
Working temperature: -10°C/+80°C



DN				Kg	EPDM ACS
mm	inch	L (mm)	Ref.		
50	2"	40	7,5	VG6400-03EA0050	
65	2 1/2"	40	7,8	VG6400-03EA0065	
80	3"	50	8,4	VG6400-03EA0080	
100	4"	50	12,5	VG6400-03EA0100	
125	5"	50	16,4	VG6400-03EA0125	
150	6"	60	20,5	VG6400-03EA0150	
200	8"	60	35,8	VG6400-03EA0200	
250	10"	70	52	VG6400-03EA0250	
300	12"	70	72	VG6400-03EA0300	
350	14"	96	129	VG6400-03EA0350	
400	16"	100	144	VG6400-03EA0400	
450	18"	106	177	VG6400-03EA0450	
500	20"	110	268	VG6400-03EA0500	
600	24"	110	351	VG6400-03EA0600	





Stainless steel body

VGA6430-03EP | VGA6430-03MM

ASA150 Vérin pneumatique | Pneumatic actuator

Vanne à guillotine à vérin pneumatique double effet - ASA 150
Knife gate valve with double-acting pneumatic actuator ASA 150



Corps : Inox 316 (CF8M)
Pelle : Inox 316L
Presse Etoupe : 2 tresses PTFE + 1 torique EPDM
Raccordement : ASA 150
Pression de service :
DN50-250 : 10 bar
DN300-450 : 7 bar
DN500-600 : 4 bar
Température de service : -10°/130°C

Body: Stainless steel 316 (CF8M)
Gate: Stainless Steel 316L
Packing: 2 PTFE packing + 1 EPDM O-ring
Connection: ASA 150
Working pressure:
DN50-250: 10 bar
DN300-450: 7 bar
DN500-600: 4 bar
Maximum Working temperature: -10°/130°C

DN		L (mm)	Kg	Etanchéité : EPDM Seat: EPDM	Etanchéité : Métal/Métal Seat: Metal/Metal
mm	inch			Ref.	Ref.
50	2"	40	7,5	VGA6430-03EP0050	VGA6430-03MM0050
65	2"1/2	40	7,8	VGA6430-03EP0065	VGA6430-03MM0065
80	3"	50	8,4	VGA6430-03EP0080	VGA6430-03MM0080
100	4"	50	12,5	VGA6430-03EP0100	VGA6430-03MM0100
125	5"	50	16,4	VGA6430-03EP0125	VGA6430-03MM0125
150	6"	60	20,5	VGA6430-03EP0150	VGA6430-03MM0150
200	8"	60	35,8	VGA6430-03EP0200	VGA6430-03MM0200
250	10"	70	52	VGA6430-03EP0250	VGA6430-03MM0250
300	12"	70	72	VGA6430-03EP0300	VGA6430-03MM0300
350	14"	96	129	VGA6430-03EP0350	VGA6430-03MM0350
400	16"	100	144	VGA6430-03EP0400	VGA6430-03MM0400
450	18"	106	177	VGA6430-03EP0450	VGA6430-03MM0450
500	20"	110	268	VGA6430-03EP0500	VGA6430-03MM0500
600	24"	110	351	VGA6400-03EP0600	VGA6400-03MM0600



Utiliser de l'air comprimé conforme à la classe de pureté ISO 8573-1
Use compressed air conforming to the purity class ISO 8573-1

Autre DN sur demande / Other DN on request

VG6400-07EP | VG6400-07MM

Vérin pneumatique | Pneumatic actuator

Vanne à guillotine à vérin pneumatique simple effet N.F
Knife gate valve with single-acting pneumatic actuator N.C*



Corps : Inox 316 (CF8M)
Pelle : Inox 316L
Presse Etoupe : 2 tresses PTFE + 1 torique EPDM
Raccordement : Entre-brides PN10
Pression de service :
DN50-150 : 10 bar
DN200 : 8 bar
DN250-300 : 6 bar
Température de service : -10°/130°C

Body: Stainless steel 316 (CF8M)
Gate: Stainless steel 316L
Packing: 2 PTFE packing + 1 EPDM O-ring
Connection: Between flanges PN10
Working pressure:
DN50-150: 10 bar
DN200: 8 bar
DN250-300: 6 bar
Working temperature: -10°/130°C

DN		L (mm)	Kg	Etanchéité : EPDM Seat: EPDM	Etanchéité : Métal/Métal Seat: Metal/Metal
mm	inch			Ref.	Ref.
50	2"	40	19	VG6400-07EP0050	VG6400-07MM0050
65	2"1/2	40	22	VG6400-07EP0065	VG6400-07MM0065
80	3"	50	23	VG6400-07EP0080	VG6400-07MM0080
100	4"	50	24	VG6400-07EP0100	VG6400-07MM0100
125	5"	50	35	VG6400-07EP0125	VG6400-07MM0125
150	6"	60	36	VG6400-07EP0150	VG6400-07MM0150
200	8"	60	66	VG6400-07EP0200	VG6400-07MM0200
250	10"	70	130	VG6400-07EP0250	VG6400-07MM0250
300	12"	70	143	VG6400-07EP0300	VG6400-07MM0300

*N.O sur demande / N.O on request

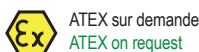

Utiliser de l'air comprimé conforme à la classe de pureté ISO 8573-1
Use compressed air conforming to the purity class ISO 8573-1



Au delà du DN300, prévoir VG double effet avec ballon réserve de secours d'air comprimé.
From DN300, plan for a double-acting VG with emergency reserve of compressed air.



Stainless steel body

VG6400-004EP | VG6400-004MM

Embase ISO | ISO mounting plate

Vanne à guillotine tige montante avec embase ISO pour motorisation électrique
Rising-stem knife gate valve with ISO mounting plate for electric actuator



Corps : Inox 316 (CF8M)
Pelle : Inox 316L
Presse Etoupe : 2 tresses PTFE + 1 torique EPDM
Raccordement : Entre-brides PN10
Pression de service :
DN50-250 : 10 bar
DN300-450 : 7 bar
DN500-600 : 4 bar
Température de service : -10°/130°C

Body: Stainless steel 316 (CF8M)
Gate: Stainless steel 316L
Packing: 2 PTFE packing + 1 EPDM O-ring
Connection: Between flanges PN10
Working pressure:
DN50-250: 10 bar
DN300-450: 7 bar
DN500-600: 4 bar
Maximum Working temperature: -10°/130°C

DN				Kg	Etanchéité : EPDM Seat: EPDM	Etanchéité : Métal/Métal Seat: Metal/Metal
mm	inch	L (mm)	Ref.		Ref.	
50	2"	40	6	VG6400-004EP0050	VG6400-004MM0050	
65	2 1/2"	40	8	VG6400-004EP0065	VG6400-004MM0065	
80	3"	50	9	VG6400-004EP0080	VG6400-004MM0080	
100	4"	50	10	VG6400-004EP0100	VG6400-004MM0100	
125	5"	50	15	VG6400-004EP0125	VG6400-004MM0125	
150	6"	60	19	VG6400-004EP0150	VG6400-004MM0150	
200	8"	60	33	VG6400-004EP0200	VG6400-004MM0200	
250	10"	70	47	VG6400-004EP0250	VG6400-004MM0250	
300	12"	70	58	VG6400-004EP0300	VG6400-004MM0300	
350	14"	96	107	VG6400-004EP0350	VG6400-004MM0350	
400	16"	100	137	VG6400-004EP0400	VG6400-004MM0400	
450	18"	106	177	VG6400-004EP0450	VG6400-004MM0450	
500	20"	110	212	VG6400-004EP0500	VG6400-004MM0500	
600	24"	110	256	VG6400-004EP0600	VG6400-004MM0600	

Pour DN supérieur, voir vannes avec réducteur motorisable
Other DN, please check the valve stem gearbox actuator operating



ATEX sur demande
ATEX on request

Version (ACS) disponible sur demande
ACS model available on request

Avec embase de motorisation et tige de manœuvre rallongée pour accouplement
With ISO mounting plate and extended operating rod for coupling

VG6400-08EP | VG6400-08MM

Réducteur manuel | Gearbox actuator

Vanne à guillotine à réducteur manuel
Knife gate valve with gearbox



Corps : Inox 316 (CF8M)
Pelle : Inox 316L
Presse Etoupe :
DN50-600 = 2 PTFE packing + 1 EPDM O-ring
DN700-800 = 3 PTFE packing + 1 EPDM O-ring
DN900-1200 = 4 PTFE packing + 1 EPDM O-ring
Raccordement : Entre-brides PN10
Pression de service :
DN350-450 : 7 bar
DN500-600 : 4 bar
DN700-1200 : 2 bar
Température de service : -10°/130°C
Manœuvre : Réducteur à volant ou motorisable

Body: Stainless steel 316 (CF8M)
Gate: Stainless steel 316L
Packing:
DN50-600 = 2 PTFE packing + 1 EPDM O-ring
DN700-800 = 3 PTFE packing + 1 EPDM O-ring
DN900-1200 = 4 PTFE packing + 1 EPDM O-ring
Connection: Between flanges PN10
Working pressure:
DN350-450: 7 bar
DN500-600: 4 bar
DN700-1200: 2 bar
Working temperature: -10°/130°C
Operation: Manual gearbox with handwheel or ISO top flange for electric actuator connection

DN				Kg	Réducteur manuel à volant Manual gearbox	
mm	inch	L (mm)	Etanchéité : EPDM Seat: EPDM		Etanchéité : Métal/Métal Seat: Metal/Metal	
				Ref.	Ref.	
350	14"	100	127	VG6400-08EP0350	VG6400-08MM0350	
400	16"	100	159	VG6400-08EP0400	VG6400-08MM0400	
450	18"	110	198	VG6400-08EP0450	VG6400-08MM0450	
500	20"	110	233	VG6400-08EP0500	VG6400-08MM0500	
600	24"	110	277	VG6400-08EP0600	VG6400-08MM0600	

DN				Kg	Réducteur motorisable Motorizable gearbox with ISO top flange	
mm	inch	L (mm)	Etanchéité : EPDM Seat: EPDM		Etanchéité : Métal/Métal Seat: Metal/Metal	
				Ref.	Ref.	
700	28"	110	612	VG6400-08EP0700	VG6400-08MM0700	
800	32"	110	657	VG6400-08EP0800	VG6400-08MM0800	
900	36"	110	917	VG6400-08EP0900	VG6400-08MM0900	
1 000	40"	110	1 260	VG6400-08EP1000	VG6400-08MM1000	
1 200	48"	120	-	VG6400-08EP1200	VG6400-08MM1200	



ATEX sur demande
ATEX on request

Version (ACS) disponible sur demande
ACS model available on request



Stainless steel body

VG6400-U04EP | VGA6430-U04

AUMA

Vanne à guillotine avec moteur AUMA - entre brides PN10 / ASA 150
Knife gate valve with AUMA electric actuator - between flanges PN10



Corps : Inox 316 (CF8M)
Pelle : Inox 316L
Presse Etoupe :
DN50-600 = 2 tresses PTFE+ 1 torique EPDM
DN700-800 = 3 tresses PTFE+ 1 torique EPDM
DN900-1200 = 4 tresses PTFE+ 1 torique EPDM
Raccordement : Entre-brides PN10 / ASA 150
Pression de service :
DN350-450 : 7 bar
DN500-600 : 4 bar
DN700-1200 : 2 bar
Température de service : -10°/130°C
Type de moteur : AUMA 400V 3PH
Equipé de capot de protection selon Directive Machine

Body: Stainless steel 316 (CF8M)
Gate: Stainless steel 316L
Packing:
DN50-600 = 2 PTFE packing + 1 EPDM O-ring
DN700-800 = 3 PTFE packing + 1 EPDM O-ring
DN900-1200 = 4 PTFE packing + 1 EPDM O-ring
Connection: Between flanges PN10 / ASA 150
Working pressure:
DN350-450: 7 bar
DN500-600: 4 bar
DN700-1200: 2 bar
Working temperature: -10°/130°C
Actuator type: AUMA 400V 3PH
Equipped with protective cover according to Machine Directive

				PN10	ASA150
DN		L (mm)	Kg	Ref.	Ref.
mm	inch				
50	2"	40	27	VG6400-U04EP0050	VGA6430-U04EP0050
65	2 1/2"	40	29	VG6400-U04EP0065	VGA6430-U04EP0065
80	3"	50	30	VG6400-U04EP0080	VGA6430-U04EP0080
100	4"	50	31	VG6400-U04EP0100	VGA6430-U04EP0100
125	5"	50	38	VG6400-U04EP0125	VGA6430-U04EP0125
150	6"	60	42	VG6400-U04EP0150	VGA6430-U04EP0150
200	8"	60	57	VG6400-U04EP0200	VGA6430-U04EP0200
250	10"	70	75	VG6400-U04EP0250	VGA6430-U04EP0250
300	12"	70	87	VG6400-U04EP0300	VGA6430-U04EP0300
350	14"	96	137	VG6400-U04EP0350	VGA6430-U04EP0350
400	16"	100	167	VG6400-U04EP0400	VGA6430-U04EP0400
450	18"	106	231	VG6400-U04EP0450	VGA6430-U04EP0450
500	20"	110	266	VG6400-U04EP0500	VGA6430-U04EP0500
600	24"	110	310	VG6400-U04EP0600	VGA6430-U04EP0600
700	28"	110	556	VG6400-U04EP0700	-
800	32"	110	679	VG6400-U04EP0800	-
900	36"	110	840	VG6400-U04EP0900	-
1 000	40"	110	1053	VG6400-U04EP1000	-
1 200	48"	120	-	VG6400-U04EP1200	-

Moteur monté sur réducteur motorisable
Actuator mounted on gearbox

Autre type d'étanchéité (NI / MM) sur demande
Other seat types available (NI/MM) on request



ATEX sur demande
ATEX on request



Version (ACS) disponible sur demande
ACS model available on request



Voir moteur AUMA seul page 125
See AUMA actuators on page 125

VG6400-031

Commande de secours | Manual emergency control

Vanne à guillotine à vérin pneumatique double effet + commande manuelle de secours
Knife gate valve with double-acting pneumatic actuator + manual emergency control



Corps : Inox 316
Pelle : Inox 316
Siège : EPDM
Presse Etoupe : 2 tresses PTFE + 1 torique EPDM
Raccordement : Entre-brides PN10
Pression de service :
DN50-250 : 10 bar
DN300-450 : 7 bar
DN500-600 : 4 bar
Température de service : -10°C/+130°C
Capot de protection : Inox 304
Vérin pneumatique double effet 6 bar équipé de commande manuelle de secours

Body: Stainless steel 316
Gate: Stainless steel 316
Seat: EPDM
Packing: 2 PTFE packing + 1 EPDM O-ring
Connection: Between flanges PN10
Working pressure:
DN50-250: 10 bar
DN300-450: 7 bar
DN500-600: 4 bar
Working temperature: -10°C/+130°C
Protective cover: Stainless steel 304
Double-acting pneumatic actuator 6 bar equipped with manual emergency control

DN		L (mm)	Kg	Ref.
mm	inch			
50	2"	40	10	VG6400-031EP0050
65	2 1/2"	40	11	VG6400-031EP0065
80	3"	50	12	VG6400-031EP0080
100	4"	50	15	VG6400-031EP0100
125	5"	50	21	VG6400-031EP0125
150	6"	60	27	VG6400-031EP0150
200	8"	60	45	VG6400-031EP0200
250	10"	70	69	VG6400-031EP0250
300	12"	70	89	VG6400-031EP0300
350	14"	96	153	VG6400-031EP0350
400	16"	100	166	VG6400-031EP0400
450	18"	106	212	VG6400-031EP0450
500	20"	110	251	VG6400-031EP0500
600	24"	110	300	VG6400-031EP0600



ATEX sur demande
ATEX on request



Voir kit de commande seul page 125
See control kit on page 125



Utiliser de l'air comprimé conforme à la classe de pureté ISO 8573-1
Use compressed air conforming to the purity class ISO 8573-1

VG BIDIRECTIONNELLE

BIDIRECTIONAL KNIFE GATE VALVE

VANNE À GUILLOTINE
KNIFE GATE VALVE



Etanchéité Bi-directionnelle

Cette vanne de construction monobloc est étanche dans les deux sens. Elle est principalement utilisée pour des liquides faiblement chargés comme les réseaux d'adduction d'eau.

✓ Bi-directional sealing

This one-piece body knife gate valve is watertight in both directions. This model is mainly used for slightly contaminated fluids like for water networks.



VANNE À GUILLOTINE BIDIRECTIONNELLE ENCOMBREMENT CONFORME À LA NORME EN558 SÉRIE 20

DN 50 à 400 - PN10

Bidirectional knife gate valves
Face to face according EN558 serie 20

DN 50 up to 400 - PN10

CORPS FONTE DUCTILE

Ductile Iron body



Pour une utilisation optimale, utilisez la pelle polie miroir. Elle permet de diminuer l'accroche des produits en position fermée. (Option de traitement de pelle sur demande, voir page 135)
For optimal use, use a mirror-polished gate. It reduces the grip of products in the closed position. (Treated gate option on request, see on page 135)

VGB3400N-001NI | VGB4400-001NI

Volant et tige non montante | Non-rising stem with handwheel

Vanne à guillotine bidirectionnelle à tige non montante à volant
Non-rising stem bidirectional type knife gate valve with handwheel



Corps : Voir tableau
Pelle : Inox 304
Siège : NBR
Presse Etoupe :
- 2 tresses PTFE
- 1 torique NBR
Raccordement :
Entre-brides PN10
Pression de service :
DN50-250 : 10 bar
DN300-400 : 7 bar
Température de service :
-10°C/+80°C

Body: See on the table
Gate: Stainless steel 304
Seat: NBR
Packing:
- 2 PTFE packing
- 1 NBR O-ring
Connection:
Between flanges PN10
Working pressure:
DN50-250: 10 bar
DN300-400: 7 bar
Working temperature:
-10°C/+80°C

JUSQU'À ÉPUISEMENT DES STOCKS WHILE STOCKS LAST

DN		L (mm)	Kg	Fonte EN-GJL-250 (GG25) Cast Iron EN-GJL-250 (GG25)	Fonte ductile Ductile Iron (GGG50)
mm	inch			Ref.	Ref.
50	2"	43	9	VGB3400N-001NI0050	VGB4400-001NI0050
65	2 1/2"	46	10	VGB3400N-001NI0065	VGB4400-001NI0065
80	3"	46	11	VGB3400N-001NI0080	VGB4400-001NI0080
100	4"	52	14	VGB3400N-001NI0100	VGB4400-001NI0100
125	5"	56	18	VGB3400N-001NI0125	VGB4400-001NI0125
150	6"	56	21	VGB3400N-001NI0150	VGB4400-001NI0150
200	8"	60	34	VGB3400N-001NI0200	VGB4400-001NI0200
250	10"	68	51	VGB3400N-001NI0250	VGB4400-001NI0250
300	12"	78	59	VGB3400N-001NI0300	VGB4400-001NI0300
350	14"	78	123	VGB3400N-001NI0350	VGB4400-001NI0350
400	16"	102	156	VGB3400N-001NI0400	VGB4400-001NI0400



Version **ACS** disponible sur demande
ACS model available on request



VGB3400N-08NI | VGB4400-08NI

Réducteur manuel | Gearbox actuator

Vanne à guillotine bidirectionnelle à réducteur manuel
Bidirectional type knife gate valve with gearbox



Corps : Voir tableau
Pelle : Inox 304
Siège : NBR
Presse Etoupe :
- 2 tresses PTFE
- 1 torique NBR
Raccordement :
Entre-brides PN10
Pression de service :
DN450 : 7 bar
DN500-600 : 4 bar
Température de service :
-10°C/+80°C
Manœuvre : Réducteur à volant ou motorisable

Body: See on the table
Gate: Stainless steel 304
Seat: NBR
Packing:
- 2 PTFE packing
- 1 NBR O-ring
Connection:
Between flanges PN10
Working pressure:
DN450: 7 bar
DN500-600: 4 bar
Working temperature:
-10°C/+80°C
Operation : Manual gearbox with handwheel or ISO top flange for electric actuator connection

JUSQU'À ÉPUISEMENT DES STOCKS
WHILE STOCKS LAST

DN				Kg	Fonte EN-GJL-250 Cast Iron EN-GJL-250	Fonte ductile Ductile Iron (GGG50)
mm	inch	L (mm)	Ref.		Ref.	
450	18"	114	243	VGB3400N-08NI0450	VGB4400-08NI0450	
500	20"	127	328	VGB3400N-08NI0500	VGB4400-08NI0500	
600	24"	154	444	VGB3400N-08NI0600	VGB4400-08NI0600	

NEW

VGB3400N-03NI | VGB4400-03NI

Vérin pneumatique | Pneumatic actuator

Vanne à guillotine bidirectionnelle à vérin pneumatique double effet
Bidirectional type knife gate valve with double-acting pneumatic actuator



Corps : Voir tableau
Pelle : Inox 304
Siège : NBR
Presse Etoupe :
- 2 tresses PTFE
- 1 torique NBR
Raccordement :
Entre-brides PN10
Pression de service :
DN50-250 : 10 bar
DN300-400 : 7 bar
Température de service :
-10°C/+80°C

Body: See on the table
Gate: Stainless steel 304
Seat: NBR
Packing:
- 2 PTFE packing
- 1 NBR O-ring
Connection:
Between flanges PN10
Working pressure:
DN50-250: 10 bar
DN300-400: 7 bar
Working temperature:
-10°C/+80°C

JUSQU'À ÉPUISEMENT DES STOCKS
WHILE STOCKS LAST

DN				Kg	Fonte EN-GJL-250 Cast Iron EN-GJL-250	Fonte ductile Ductile Iron (GGG50)
mm	inch	L (mm)	Ref.		Ref.	
50	2"	43	8	VGB3400N-03NI0050	VGB4400-03NI0050	
65	2 1/2"	46	9	VGB3400N-03NI0065	VGB4400-03NI0065	
80	3"	46	10	VGB3400N-03NI0080	VGB4400-03NI0080	
100	4"	52	13	VGB3400N-03NI0100	VGB4400-03NI0100	
125	5"	56	18	VGB3400N-03NI0125	VGB4400-03NI0125	
150	6"	56	21	VGB3400N-03NI0150	VGB4400-03NI0150	
200	8"	60	36	VGB3400N-03NI0200	VGB4400-03NI0200	
250	10"	68	57	VGB3400N-03NI0250	VGB4400-03NI0250	
300	12"	78	77	VGB3400N-03NI0300	VGB4400-03NI0300	
350	14"	78	138	VGB3400N-03NI0350	VGB4400-03NI0350	
400	16"	102	173	VGB3400N-03NI0400	VGB4400-03NI0400	
450	18"	114	237	VGB3400N-03NI0450	VGB4400-03NI0450	
500	20"	127	291	VGB3400N-03NI0500	VGB4400-03NI0500	
600	24"	154	-	VGB3400N-03NI0600	VGB4400-03NI0600	

NEW



Utiliser de l'air comprimé lubrifié conforme à la classe de pureté ISO 8573-1
Use lubricated compressed air conforming to the purity class ISO 8573-1

VGB4400-004NI

Embase ISO | ISO mounting plate

Vanne à guillotine bidirectionnelle avec platine ISO motorisable
Bidirectional type knife gate valve with ISO mounting plate for electric actuator



Corps : Voir tableau
Pelle : Inox 304
Siège : NBR
Presse Etoupe :
- 2 tresses PTFE
- 1 torique NBR
Raccordement :
Entre-brides PN10
Pression de service :
DN50-250 : 10 bar
DN300-450 : 7 bar
DN500-600 : 4 bar
Température de service :
-10°C/+80°C

Body: See on the table
Gate: Stainless steel 304
Seat: NBR
Packing:
- 2 PTFE packing
- 1 NBR O-ring
Connection:
Between flanges PN10
Working pressure:
DN50-250: 10 bar
DN300-450: 7 bar
DN500-600: 4 bar
Working temperature:
-10°C/+80°C

DN				Kg	Fonte ductile Ductile Iron (GGG50)
mm	inch	L (mm)	Ref.		
50	2"	43	8	VGB4400-004NI0050	
65	2 1/2"	46	9	VGB4400-004NI0065	
80	3"	46	10	VGB4400-004NI0080	
100	4"	52	13	VGB4400-004NI0100	
125	5"	56	18	VGB4400-004NI0125	
150	6"	56	21	VGB4400-004NI0150	
200	8"	60	36	VGB4400-004NI0200	
250	10"	68	57	VGB4400-004NI0250	
300	12"	78	77	VGB4400-004NI0300	
350	14"	78	138	VGB4400-004NI0350	
400	16"	102	173	VGB4400-004NI0400	
450	18"	114	243	VGB4400-004NI0450	
500	20"	127	328	VGB4400-004NI0500	
600	24"	157	444	VGB4400-004NI0600	

NEW



Moteur électrique page 125
Electric actuator on page 125

VG PELLE TRAVERSANTE

THROUGH CONDUIT KNIFE GATE VALVE



Pas de zone de rétention

Cette vanne est constituée d'un corps en deux parties sans zone de rétention avec deux joints de siège qui permettent une étanchéité bidirectionnelle. Elle est particulièrement adaptée en papeterie, en sortie de pulpeur ou sous des silos.

✓ No retention zone

This valve has a two-piece body without a retention zone, with two seat gaskets, allowing a bidirectional tightness. It is especially adapted for the pulp and paper industry, at pulp outlets or under silos.



Idéal pour fluides très épais (pâte à papier...)
Ideal for very thick fluids (paper pulp...)

VANNE A GUILLOTINE PELLE TRAVERSANTE

NEW

"Nouvelle technologie" :
Amélioration du guidage de la pelle.

Through conduit knife gate valve

"New technology":
Improved gate guiding.



L'ensemble des accessoires sont identiques aux VG standards.
See all accessories for standard KGV.

VGT3400-00 | VGT4400-00

Vanne à guillotine à pelle traversante à volant
Through conduit type knife gate valve with handwheel



Corps : Voir tableau
Pelle : Inox 304
Siège : NBR
Presse Etoupe :
- 2 tresses PTFE
- 1 torique NBR
Raccordement :
Entre-bridés PN10
Pression de service :
DN50-250 : 10 bar
DN300-400 : 6 bar
Température de service :
-10°C/+80°C

Body: See on the table
Gate: Stainless steel 304
Seat: NBR
Packing:
- 2 PTFE packing
- 1 NBR O-ring
Connection:
Between flanges PN10
Working pressure:
DN50-250: 10 bar
DN300-400: 6 bar
Working temperature:
-10°C/+80°C

Sur demande :
- Moteur électrique
- DN > 400

On request:
- Electric actuator
- DN > 400



JUSQU'À ÉPUISEMENT DES STOCKS WHILE STOCKS LAST

DN			Kg	Fonte EN-GJL-250 Cast iron EN-GJL-250	Fonte ductile Ductile Iron (GGG50)
	mm	inch		Ref.	Ref.
50	2"	40	13	VGT3400-00NI0050	VGT4400-00NI0050
65	2 1/2"	40	15	VGT3400-00NI0065	VGT4400-00NI0065
80	3"	50	19	VGT3400-00NI0080	VGT4400-00NI0080
100	4"	50	23	VGT3400-00NI0100	VGT4400-00NI0100
125	5"	50	29	VGT3400-00NI0125	VGT4400-00NI0125
150	6"	60	38	VGT3400-00NI0150	VGT4400-00NI0150
200	8"	60	65	VGT3400-00NI0200	VGT4400-00NI0200
250	10"	70	100	VGT3400-00NI0250	VGT4400-00NI0250
300	12"	70	122	VGT3400-00NI0300	VGT4400-00NI0300
350	14"	96	163	VGT3400-00NI0350	VGT4400-00NI0350
400	16"	100	235	VGT3400-00NI0400	VGT4400-00NI0400

VGT3400-03 | VGT4400-03

Vanne à guillotine à pelle traversante à vérin pneumatique double effet
Through conduit type knife gate valve with double-acting pneumatic actuator



Corps : Voir tableau
Pelle : Inox 304
Siège : NBR
Presse Etoupe :
- 2 tresses PTFE
- 1 torique NBR
Raccordement :
Entre-bridés PN10
Pression de service :
DN50-250 : 10 bar
DN300-400 : 6 bar
Température de service :
-10°C/+80°C

Body: See on the table
Gate: Stainless steel 304
Seat: NBR
Packing:
- 2 PTFE packing
- 1 NBR O-ring
Connection:
Between flanges PN10
Working pressure:
DN50-250: 10 bar
DN300-400: 6 bar
Working temperature:
-10°C/+80°C



JUSQU'À ÉPUISEMENT DES STOCKS WHILE STOCKS LAST

DN			Kg	Fonte EN-GJL-250 Cast iron EN-GJL-250	Fonte ductile Ductile Iron (GGG50)
	mm	inch		Ref.	Ref.
50	2"	40	10	VGT3400-03NI0050	VGT4400-03NI0050
65	2 1/2"	40	12	VGT3400-03NI0065	VGT4400-03NI0065
80	3"	50	18	VGT3400-03NI0080	VGT4400-03NI0080
100	4"	50	24	VGT3400-03NI0100	VGT4400-03NI0100
125	5"	50	31	VGT3400-03NI0125	VGT4400-03NI0125
150	6"	60	39	VGT3400-03NI0150	VGT4400-03NI0150
200	8"	60	67	VGT3400-03NI0200	VGT4400-03NI0200
250	10"	70	126	VGT3400-03NI0250	VGT4400-03NI0250
300	12"	70	138	VGT3400-03NI0300	VGT4400-03NI0300
350	14"	96	200	VGT3400-03NI0350	VGT4400-03NI0350
400	16"	100	281	VGT3400-03NI0400	VGT4400-03NI0400



Equipé de carters de protection Inox
Equipped with Stainless steel protective housings



VG SOUS SILO

UNDER SILO KNIFE GATE VALVE

VANNE À GUILLOTINE SOUS SILO

DN150 à 400

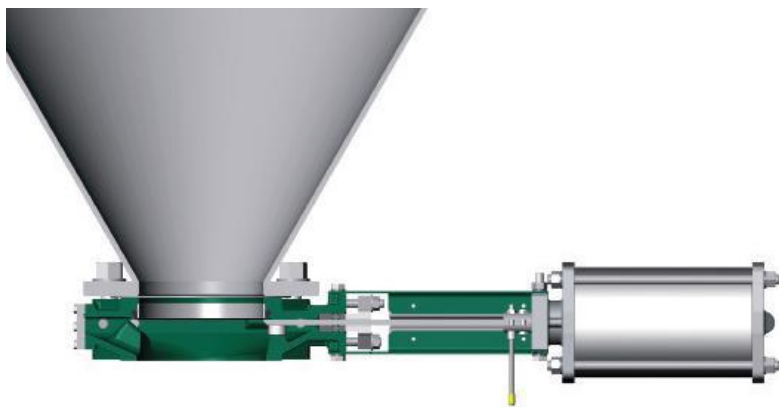

Idéal pour silos de grains, cimenteries, pulvérulents
Ideal for grain silos, cement factories, powders

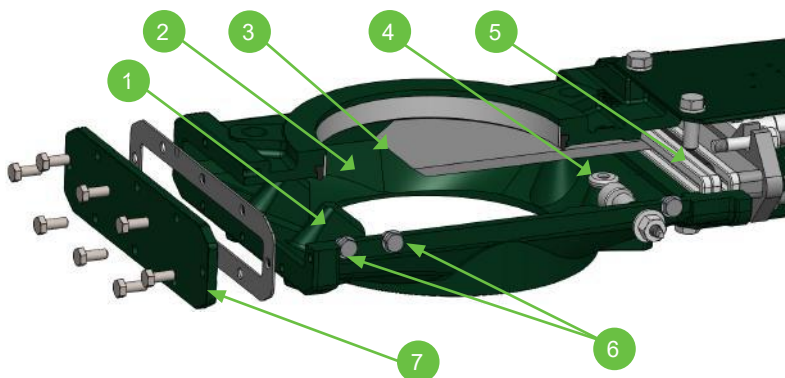

Under silo knife gate valves

DN150 up to 400

- 1 Butées de pelle : pas de zone de rétention.
Steel reinforced gate: no retention zone.
- 2 Corps large et évasé : pas d'accumulation, passage du produit facilité.
Wide body: ease of product evacuation.
- 3 Pelle plate et tranchante avec chanfrein : attaque franche.
Sharp gate with beveled edge straight cut.
- 4 Guidage de la pelle par doigts PTFE : peu de frottements.
Gate guided by PTFE rubbing plates: low friction.
- 5 Tresse effet racleur : nettoyage de la pelle lors des mouvements.
Packing with scraper effect: ease of gate cleaning.
- 6 Trous de soufflage : nettoyage du corps simplifié.
Flushing holes: easy cleaning of the body.
- 7 Fond démontable pour nettoyer sans démonter la vanne.
Removable bottom for cleaning without dismantling the valve.

Étanche aux poudres, ne pas utiliser avec de l'eau.
Powder tight, do not use with water.

VGS3400-03 | VGS4400-03

Sous silo | Under silo

Vanne à guillotine sous silo à vérin pneumatique double effet

Under silo knife gate valve with double-acting pneumatic actuator



Corps : Voir tableau
 Pelle : Inox 304
 Siège : NBR
 Raccordement : Entre-brides PN10
 Pression de service : DN150: 2,5 bar
 DN200 : 2 bar
 DN250-300 : 1,5 bar
 DN350-400 : 1,3 bar
 Working temperature: -10°C/+80°C
 Trous de soufflage : Nettoyage du corps simplifié
 Fond démontable

Body: See on the table
 Gate: Stainless steel 304
 Seat: NBR
 Connection: Between flanges PN10
 Working pressure: DN150: 2,5 bar
 DN200: 2 bar
 DN250-300: 1,5 bar
 DN350-400: 1,3 bar
 Working temperature: -10°C/+80°C
 Flushing holes: Body cleaning simplified
 Dismantling bottom

CE



ATEX sur demande
 ATEX on request

JUSQU'À ÉPUISEMENT DES STOCKS WHILE STOCKS LAST

DN		T L (mm)	Kg	Fonte EN-GJL-250 Cast iron EN-GJL-250	Fonte ductile Ductile iron (GGG50)
mm	inch			Ref.	Ref.
150	6"	60	39	VGS3400-03NI0150	VGS4400-03NI0150
200	8"	60	67	VGS3400-03NI0200	VGS4400-03NI0200
250	10"	70	126	VGS3400-03NI0250	VGS4400-03NI0250
300	12"	70	138	VGS3400-03NI0300	VGS4400-03NI0300
350	14"	96	200	VGS3400-03NI0350	VGS4400-03NI0350
400	16"	100	281	VGS3400-03NI0400	VGS4400-03NI0400



Équipé de carters de protection inox
Equipped with Stainless steel protective housings

NEW

AUTRES MODÈLES | OTHER MODELS

VG À MANCHON | VG HAUTE PRESSION
PINCH KNIFE GATE VALVE | HIGH PRESSURE KNIFE GATE VALVE

DISPONIBLE SUR DEMANDE | ON REQUEST

(Étude particulière selon vos exigences pour un produit le plus adapté, nous consulter)
(Contact us for a specific study according to your needs for a better adapted product)

GAMME VGP

A manchon | Pinch

Vanne à guillotine à manchon
Pinch knife gate valve



Mines
Mining industry

Application : Vanne adaptée aux transports de produits abrasifs
Prix sur demande

Application: Valve used for transport of abrasive products
Price on request



GAMME VG

Haute température | High temperature

Vanne à guillotine T° max 500°C
Max Temperature 500°C



Application : Vanne adaptée aux très hautes températures
Prix sur demande

Application: Valve used for very high temperature
Price on request

GAMME VGH

Haute pression | High pressure

Vanne à guillotine à chapeau boulonné
Bolted bonnet knife gate valve



Pour haute pression
For high pressure

Application : Vanne appropriée aux liquides clairs ou faiblement chargés à des pressions élevées (40 bar)
Prix sur demande

Application: Valve used for clean water or with a low concentration of solids at high pressure (40 bar)
Price on request

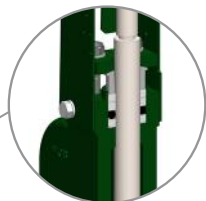

GAMME VGB

Biogaz | Biogas

Vanne à guillotine bidirectionnelle spéciale biogaz
Biogas bidirectional knife gate valve



Pour applications biogaz
For biogas applications

ASSEMBLAGE SPÉCIAL

Kit de tresses renforcées en fibres Aramide

Application BIOGAZ pour une performance maximale :
- excellente tenue mécanique
- bonne résistance sur fluides abrasifs
- auto lubrifiante
- tresse exempte de silicone

SPECIAL ASSEMBLY

Packing reinforced with Aramide fibers

BIOGAS application for maximum performance:
- Excellent mechanical strength
- Good resistance to abrasive fluids
- Self-lubricating
- Packing silicone-free



Modèle VGB pages 118-119
VGB type on pages 118-119



Kit tresses BIOGAZ page 140
Special biogas packing on page 140



KIT VG

ACCESSOIRES, OPTIONS ET MOTORISATIONS ACCESSORIES, OPTIONS AND ACTUATORS

Commandes pour vannes à guillotine | Knife gate valve actuators

CARRÉ DE FONTAINIER CONIQUE | SQUARE ADAPTOR

Carré de manœuvre pour vanne à guillotine tige non montante
Square adaptor for non-rising stem knife gate valve



Matière : Fonte FT25
Dimensions : 30x30

Material: Cast Iron FT25
Dimensions: 30x30

DN		Ref.
mm	inch	
50-150	2"-6"	VGCARRENM1
200-300	8"-12"	VGCARRENM2
350-600	14"-24"	VGCARRENM3

DN supérieurs sur demande / Other DN on request



Voir clé de fontainier page 143
See lever wrench on page 143

KIT VOLANT À CHAÎNE | CHAINWHEEL KIT

Volant à chaîne pour vanne à guillotine
Chainwheel kit for knife gate valve

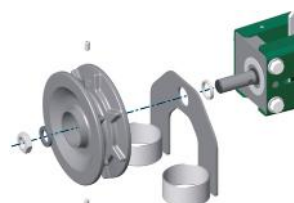

Composé de :
- Entretoise acier au carbone
- Volant à chaîne acier au carbone
- Guide chaîne Inox 304

Comprised of:
- Carbonne steel spacer
- Carbon steel chainwheel
- Stainless steel 304 guide

Remplace le volant standard

Replaces the standard handwheel

DN		Ref.
mm	inch	
50 - 150	2"-6"	30000014
200 - 300	8"-12"	30000015
350 - 450	14"-18"	30000016
500 - 600	20"-24"	30000017

Matière / Material	Ref.
Acier / Steel	VGCHAINE-AC01
Inox / Stainless steel	VGCHAINE-IN01

EN OPTION | OPTION

Chaîne acier ou inox / Prix au mètre
Steel or Stainless steel chain / Price per meter

Très utilisé pour les installations en hauteur avec des accès difficiles. Le volant se place en position verticale.
Widely used in high installations with difficult access. The steering wheel is placed in a vertical position.



Support non inclus
Support not included

KIT SYSTEME CADENASSABLE | LOCKING KIT

Kit VG à levier / volant cadenassable
Lever or handwheel locking kit



Levier :
- Cadenas laiton
- Plaque de verrouillage VG à levier inox 304
Position ouverte et fermée.

Volant :
- Cadenas
- Plaque de verrouillage VG à volant inox 304
- Câble de consignation

Lever:
- Brass locker
- Stainless steel 304 locking plate for VG with lever
Open and closed position.

Handwheel:
- Brass locker
- Stainless steel 304 locking plate for VG with handwheel
- Lockout cable

DN		Ref.	Modèle / Model
mm	inch		
50 - 300	2" - 12"	300200316	LEVIER / LEVER
50-150	2"-6"	300200347	VOLANT / HANDWHEEL
200-300	8"-12"	300200348	VOLANT / HANDWHEEL
350-600	14"-24"	300200349	VOLANT / HANDWHEEL

VERIN | PNEUMATIC ACTUATOR

Vérin double effet

Double-acting pneumatic actuator



Pression de service : 5 à 7 bar (air lubrifié)
Corps et flasques : Aluminium

Working pressure: 5 to 7 bar (lubricated air)
Body and flanges: Aluminium

DN		Ref.	DN		Ref.
mm	inch		mm	inch	
50	2"	VGVERINDE-0050	350	14"	VGVERINDE-0350
65	2"1/2	VGVERINDE-0065	400	16"	VGVERINDE-0400
80	3"	VGVERINDE-0080	450	18"	VGVERINDE-0450
100	4"	VGVERINDE-0100	500	20"	VGVERINDE-0500
125	5"	VGVERINDE-0125	600	24"	VGVERINDE-0600
150	6"	VGVERINDE-0150	700	28"	VGVERINDE-0700
200	8"	VGVERINDE-0200	800	32"	VGVERINDE-0800
250	10"	VGVERINDE-0250	1000	40"	VGVERINDE-1000
300	12"	VGVERINDE-0300			



Pièces détachées pour vérin | Actuator spare parts

KIT DE JOINTS | GASKETS KIT

Kit de joints pour vérin double effet

Gaskets kit for double-acting pneumatic actuator



2 joints toriques / 2 o-rings
1 joint cache poussières / 1 dust cap
1 joint d'étanchéité / 1 gasket
1 o-ring de piston / 1 piston o-ring

DN		Ref.
mm	inch	
50/65/80	2" / 2"1/2 / 3"	VGKITVERINDE-0050
100	4"	VGKITVERINDE-0100
125/150	5" / 6"	VGKITVERINDE-0125
200	8"	VGKITVERINDE-0200
250/300	10" / 12"	VGKITVERINDE-0250
350/400/450	14" / 16" / 18"	VGKITVERINDE-0350
500	20"	VGKITVERINDE-0500
600	24"	VGKITVERINDE-0600
700	28"	VGKITVERINDE-0700

PISTON | PISTON

Piston pour vérin double effet

Piston for double-acting pneumatic actuator



Matière : Nitrile

Material: Nitrile

DN		Ref.
mm	inch	
50/65/80	2" / 2"1/2 / 3"	VGPISTOVERIN-0050
100	4"	VGPISTOVERIN-0100
125/150	5" / 6"	VGPISTOVERIN-0125
200	8"	VGPISTOVERIN-0200
250/300	10" / 12"	VGPISTOVERIN-0250
350/400/450	14" / 16" / 18"	VGPISTOVERIN-0350
500/600	20" / 24"	VGPISTOVERIN-0500

TIRANTS | THREADED RODS

Kit tirants INOX pour VG vérin

Stainless steel threaded rods for knife gate valve actuators

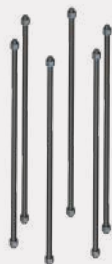

Idéal sur ambiance corrosive
For corrosive environments

DN		Inox 304 (A2)	Inox 316 (A4)
mm	inch	Ref.	Ref.
50	2"	300160018	300160032
65	2"1/2	300160019	300160033
80	3"	300160020	300160034
100	4"	300160021	300160035
125	5"	300160022	3001z60036
150	6"	300160023	300160037
200	8"	300160024	300160038
250	10"	300160025	300160039
300	12"	300160026	300160040
350	14"	300160027	300160041
400	16"	300160028	300160042
450	18"	300160029	300160043
500	20"	300160030	300160044
600	24"	300160031	300160045

DN supérieurs sur demande / Other DN on request





(Suite) Commandes pour vanne à guillotine | Knife gate valve actuators

COMMANDE DE SECOURS | EMERGENCY HANDWHEEL

Commande manuelle de secours pour vanne à guillotine standard à actionneur pneumatique
Manual emergency handwheel for standard knife gate valve with pneumatic actuator



Commande manuelle de secours à goupiller
Manual emergency control with pin



Composé de :
- 1 vérin pneumatique avec tige sortante inox + volant
- 2 plaques support acier peint époxy

Comprised of:
- 1 pneumatic actuator with Stainless steel rising-stem + handwheel
- 2 Epoxy-coated steel support plates



Prix à ajouter à la vanne à volant
Price to be added to standard valve with handwheel

DN		Ref.
mm	inch	
50	2"	KITVGERINDECMS-0050
65	2 1/2"	KITVGERINDECMS-0065
80	3"	KITVGERINDECMS-0080
100	4"	KITVGERINDECMS-0100
125	5"	KITVGERINDECMS-0125
150	6"	KITVGERINDECMS-0150
200	8"	KITVGERINDECMS-0200
250	10"	KITVGERINDECMS-0250
300	12"	KITVGERINDECMS-0300
350	14"	KITVGERINDECMS-0350
400	16"	KITVGERINDECMS-0400
450	18"	KITVGERINDECMS-0450
500	20"	KITVGERINDECMS-0500
600	24"	KITVGERINDECMS-0600

DN supérieurs sur demande / Other DN on request

U04 - MOTEUR VG STANDARD | U04 AUMA ACTUATOR FOR STANDARD KNIFE GATE VALVE

Moteur électrique AUMA pour vanne à guillotine
3-phase AUMA actuator for knife gate valve



auma
Technik für anspruchsvolle Aufgaben

Autres tensions ou options sur demande
Other voltages or options on request



Tension : 3P 400V / 50 Hz
Application : Tout ou rien
- 2 contacts fin de course
- 2 limiteurs de couple
- 1 résistance de chauffe
Commande manuelle de secours IP68

Voltage: 3P 400V / 50 Hz
Application: On/off
- 2 limit switches
- 2 torque limiters switches
- 1 heat resistor

Emergency handwheel IP68

Moteur monté sur réducteur motorisable
Actuator mounted on motorizable gearbox

VG standard (VG3400 / VG4400 / VG6400) Standard knife gate valve			VGB (bidirectionnelle) Bidirectional type knife gate valve		
DN		Ref.	DN		Ref.
mm	Type		mm	Type	
50-100	7.2	VGMOTELEC-SA07.21	50-100	7.2	300190232
125	7.6	VGMOTELEC-SA07.61	125-150	7.6	300190233
150			200-300	10.2	300190234
200			350-500	14.2	300190236
300			600	14.6	300190237
250	10.2	VGMOTELEC-SA10.21			
350					
400					
450-600	14.2	VGMOTELEC-SA14.21			
700	10.2	SA102U04B3TOR180T			
800					
900					
1000					
1200	14.2	SA142U04B3TOR180T			



Voir guide technique pages 342 à 344
See technical guide on pages 342 up to 344



Electrodistributeur NON ATEX | NON-ATEX solenoid valves

ELECTRODISTRIBUTEUR EN LIGNE NON ATEX | NON-ATEX IN LINE SOLENOID VALVE

Monostable

Electrodistributeur ASCO monostable G551A017 G1/4 montage en ligne NON ATEX
 ASCO model G551A017 G1/4 NON-ATEX solenoid valve monostable in-line editing



Commande électropneumatique (avec commande manuelle)
 5/2 monostable rappel ressort
 Raccordement G1/4 (en ligne sans bobine)
 Avec commande manuelle
 IP65
 Aluminium anodisé noir
 Pression différentielle : 2-10bar
 Plage de température : -25°C / +60°
 Débit : 860 l/min

Electro-pneumatic control (with manual override)
 5/2 monostable spring return
 Connection G1/4
 With manual override
 IP65
 Anodized aluminium
 Differential pressure: 2-10bar
 Temperature range: -25°C / +60°C
 Flow rate: 860 l/min

Voltage	Ref.
24VAC	300180079
24VCC	300180080
48VAC	300180081
48VCC	300180082
230VAC	300180083



Kit composé de :
 - Electrodistributeur en ligne mono
 - Bobine + connecteur
 - Raccords coudés auto-bloquants
 - Tube rilsan + vis

Kit
 - Solenoid valve
 - Coil + connector
 - Connection
 - Rilsan tube internal + screws

ELECTRODISTRIBUTEUR EN LIGNE GRAND DEBIT NON ATEX | NON-ATEX IN-LINE HIGH FLOW SOLENOID VALVE

Monostable

Electrodistributeur ASCO monostable G553A017 G1/2 montage en ligne NON ATEX
 ASCO NON-ATEX model G553A017 G1/2 solenoid valve monostable in-line editing



Commande électropneumatique (avec commande manuelle)
 5/2 monostable rappel ressort
 Raccordement G1/2
 IP65
 Bobine + connecteur
 Aluminium anodisé noir
 Pression différentielle : 2-10bar
 Plage de température : -25°C / +60°
 Débit : 3800 l/min

Electro-pneumatic control (with manual override)
 5/2 monostable spring return
 Connection G1/2
 IP65
 Coil + connector
 Anodized aluminium
 Differential pressure: 2-10bar
 Temperature range: -25°C / +60°C
 Flow rate: 3800 l/min

Voltage	Ref.
24VAC/50-60 Hz	G553A017S3AN
24VCC	G553A017S3D2
48VAC/50-60 Hz	G553A017S3AP
48VCC	G553A017S3D3
115VAC/50 Hz	G553A017S3A5
230VAC/50 Hz	G553A017S3A8



Electrotributeur grand débit : 3800 L/min (à 6 bar)
High flow solenoid valve : 3800 L/min (at 6 bar)

POUR MODELES A PARTIR DU DN500
 For models from the DN500

ELECTRODISTRIBUTEUR EN LIGNE NON ATEX | NON-ATEX IN LINE SOLENOID VALVE

Bistable

Electrodistributeur ASCO bistable G551A018 G1/4 montage en ligne NON ATEX
 ASCO model G551A018 G1/4 NON-ATEX solenoid valve bistable in-line editing



Commande électropneumatique (avec commande manuelle)
 5/2 bistable commandé par 2 bobines
 Raccordement G1/4 (en ligne sans bobine)
 Avec commande manuelle
 IP65
 Bobine + connecteur
 Aluminium anodisé noir
 Pression différentielle : 2-10bar
 Plage de température : -25°C / +60°
 Débit : 860 l/min

Electro-pneumatic control (with manual override)
 5/2 bistable controlled by 2 coils
 Connection G1/4
 With manual override
 IP65
 Coil + connector
 Anodized aluminium
 Differential pressure: 2-10bar
 Temperature range: -25°C / +60°C
 Flow rate: 860 l/min



Voltage	Ref.
24VAC	G551A018MS.24/50-60
24VCC	G551A018MS.24/DC
48VCC	G551A018MS.48/50-60
48VAC	G551A018MS.48/DC
230VCC	G551A018MS.230/50

ELECTRODISTRIBUTEUR EN LIGNE GRAND DEBIT NON ATEX | NON-ATEX IN LINE HIGH FLOW SOLENOID VALVE

Bistable

Electrodistributeur ASCO bistable G553A018 G1/2 montage en ligne NON ATEX
 ASCO model G553A018 G1/2 NON-ATEX solenoid valve bistable in-line editing



Commande électropneumatique (avec commande manuelle)
 5/2 bistable
 Raccordement G1/2
 IP65
 Bobine + connecteur
 Aluminium anodisé noir
 Pression différentielle : 2-10bar
 Plage de température : -25°C / +60°
 Débit : 3800 l/min

Electro-pneumatic control (with manual override)
 5/2 bistable
 Connection G1/2
 IP65
 Coil + connector
 Anodized aluminium
 Differential pressure: 2-10bar
 Temperature range: -25°C / +60°C
 Flow rate: 3800 l/min



Voltage	Ref.
24VAC	G553A018MS.24/50-60
24VDC	G553A018MS.24/DC
48VAC	G553A018MS.48/50-60
48VDC	G553A018MS.48/DC
230VAC	G553A018MS.230/50

Electrotributeur grand débit : 3800 L/min (à 6 bar)
High flow solenoid valve : 3800 L/min (at 6 bar)

POUR MODELES A PARTIR DU DN500
 For models from the DN500

Electrodistributeurs ATEX | ATEX solenoid valves



Voir guide technique page 341
See technical guide on page 341

Des produits conformes à la directive ATEX 2014/34/UE

Products comply with the ATEX directive 2014/34/EU

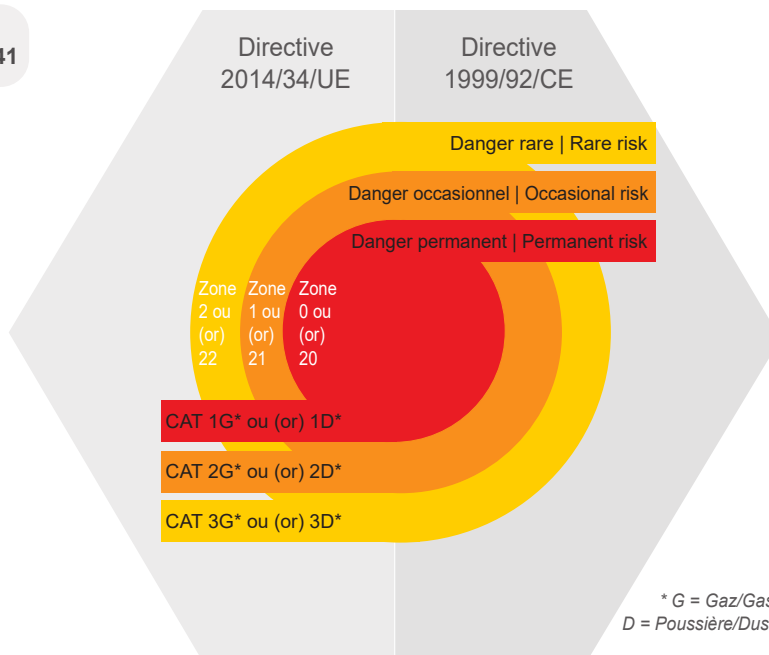

ELECTRODISTRIBUTEUR EN LIGNE ATEX | ATEX IN LINE SOLENOID VALVE

Electrodistributeur ASCO montage en ligne ATEX
ASCO ATEX solenoid valve in-line editing



Commande électropneumatique (sans commande override)
5/2 monostable rappel ressort
Raccordement G1/4
Distributeur avec bobine époxy ATEX IP65
Aluminium anodisé noir
Pression différentielle : 2-10bar
Plage de température : -10°C / +50°
Débit : 860 l/min (à 6 bar)
Protection Ex tc

Electro-pneumatic control (without manual override)
5/2 monostable spring return
Connection G1/4
Distributor with ATEX epoxy coil IP65
Anodized aluminium
Differential pressure: 2-10bar
Temperature range: -10°C / +50°C
Flow rate: 860 l/min (at 6 bar)
Ex tc protection

Voltage	Ref.
24VDC	SGG551A017.24/DC
230VAC	SGG551A017.230/50-60

3G T4 Zone 2
3D T115°C Zone 22

ELECTRODISTRIBUTEUR EN LIGNE ATEX | ATEX IN LINE SOLENOID VALVE

Electrodistributeur ASCO montage en ligne ATEX
ASCO ATEX solenoid valve in-line editing



Commande électropneumatique (sans commande manuelle)
5/2 monostable rappel ressort
Raccordement G1/4
Distributeur avec bobine intégrée dans un boîtier Aluminium antidéflagrant IP67
Aluminium anodisé noir
Pression différentielle : 2-10bar
Plage de température : -25°C / +60°
Débit : 860 l/min (à 6 bar)
Protection Ex d et Ex tb

Electro-pneumatic control (without manual override)
5/2 monostable spring return
Connection G1/4
Distributor with coil integrated in an explosion proof Aluminium box IP67
Anodized aluminium
Differential pressure: 2-10bar
Temperature range: -25°C / +60°C
Débit: 860 l/min (at 6 bar)
Ex d and Ex tb protection

Voltage	Ref.
24VDC	LPKFG551B317.24/DC
230VAC	LPKFG551B317.230/50

2G T6 Zone 1
2D T135°C Zone 21



ELECTRODISTRIBUTEUR EN LIGNE ATEX | ATEX IN LINE SOLENOID VALVE

Electrodistributeur ASCO montage en ligne ATEX

ASCO ATEX solenoid valve in-line editing



Commande électropneumatique (sans commande manuelle)
5/2 monostable rappel ressort
Raccordement G1/4
Distributeur avec bobine ATEX IP65
Aluminium anodisé noir
Pression différentielle : 2-10bar
Plage de température : -25°C / +60°
Débit : 860 l/min (à 6 bar)
Protection EX ia et Ex ib (sécurité intrinsèque)

Electro-pneumatic control (without manual override)
5/2 monostable spring return
Connection G1/4
Distributor with ATEX epoxy coil IP65
Anodized aluminium
Differential pressure: 2-10bar
Temperature range: -25°C / +60°C
Débit: 860 l/min (at 6 bar)
EX ia and Ex ib protection (intrinsic safety)

Voltage	Ref.
24VDC	LISCG551B217.24/DC

2G T6 Zone 1
2D T85°C Zone 21



SILENCIEUX | SILENCER

Silencieux d'échappement pour électrodistributeur

Silencer for solenoid valve



Corps : Laiton
Raccordement : Fileté BSP

Body: Brass
Connection: Male BSP

DN	Ref.
1/8"	EDSILENCE-0005
1/4"	EDSILENCE-0008
3/8"	EDSILENCE-0010

Réduit le bruit d'échappement à la sortie de l'air.
Decrease the exhaust noise at the air outlet.

FREIN | THROTTLE

Frein d'échappement réglable

Adjustable throttle valve



Corps : Laiton
Raccordement : Mâme BSP

Body: Brass
Connection: Male BSP

DN	Ref.
1/8"	EDFREIN-0005
1/4"	EDFREIN-0008

Ralentit le temps de manoeuvre des vannes (ouverture et/ou fermeture)
Slows the valve's operating time (opening and / or closing)

REGULATEUR | REGULATOR

Régulateur pour air comprimé

Regulator for compressed air



Corps : Aluminium
Tube : Polycarbonate
Température de service : -10/+60°C
Pression de service : 0,5 à 10 bar
Précision du régulateur: 0,2 bar
Raccordement: Femelle BSP
Avec manomètre et support
Voir les courbes de débits (L/min) selon la pression d'entrée et de sortie sur le passeport technique

Body: Aluminium
Tube: Polycarbonate
Working temperature: -10/+60°C
Working pressure: 0,5 to 10 bar
Regulator precision: 0,2 bar
Connection: Female BSP
With pressure gauge and mounting kit
Consult the technical data sheet for the flows curve.

DN	Ref.
1/4"	FRL1733-0008
3/8"	FRL1733-0010
1/2"	FRL1733-0015

FILTRE REGULATEUR | REGULATOR FILTER

Filtre régulateur pour air comprimé

Regulator filter for compressed air



Corps : Aluminium
Tube : Polycarbonate
Filtration : 5µ
Température de service : 0/+50°C
Pression de service :
1/4"-1/2" : 10 bar
3/4"-1" : 12 bar
1 cartouche de filtration

Body: Aluminium
Tube: Polycarbonate
Filtration: 5µ
Working temperature: 0/+50°C
Working pressure:
1/4"-1/2": 10 bar
3/4"-1": 12 bar
1 filter cartridge

DN	Ref.
1/4"	FRL1731-0008
3/8"	FRL1731-0010
1/2"	FRL1731-0015

FILTRE REGULATEUR LUBRIFICATEUR | LUBRICATOR REGULATOR FILTER

Lubrificateur | Lubricator

Filtre régulateur et lubrificateur pour air comprimé
Lubricator filter + regulator for compressed air



Corps : Aluminium
Tube : Polycarbonate
Filtration : 5µ
Température de service : 0/+50°C
Pression de service :
1/4"-1/2" : 10 bar
3/4"-1" : 12 bar
2 cartouches de filtration

Body: Aluminium
Tube: Polycarbonate
Filtration: 5µ
Working temperature: 0/+50°C
Working pressure:
1/4"-1/2": 10 bar
3/4"-1": 12 bar
2 filter cartridges

DN	Ref.
1/4"	FRL1730-0008
3/8"	FRL1730-0010
1/2"	FRL1730-0015



Faible encombrement. Garantit un apport d'air de qualité et assure le rendement des équipements.
Small footprint, low mass. Guarantees quality air supply and ensures the performance of the equipment.



Electropositionneurs numériques | Digital electropositioners



Un électropositionneur peut coûter jusqu'à 20% de son prix d'achat par an en air comprimé ! Le modèle SIPART de Siemens® offre une faible consommation d'air (36 NI/h) ce qui le place parmi le meilleur du marché.
An electro pneumatic positioner can cost up to 20% of its purchase price in compressed air per year! The Siemens SIPART® offers low air consumption (36NI/h), placing it as one of the best on the market.

ELECTROPOSITIONNEUR POUR VERIN DOUBLE EFFET | ELECTROPOSITIONER FOR DOUBLE-ACTING ACTUATOR

Electropositionneur numérique modèle SIEMENS SIPART - PS2 pour vérin double effet
SIEMENS electropositioner type SIPART -PS2 for double-acting actuator type



Type : Electro-pneumatique pour vérin double effet
Température de fonctionnement : -30°C/+80°C
Pression d'alimentation : 1,4 à 7 bar
Boîtier : Macrolon®
IP66
Affichage : Par écran LCD
Signal de commande : 4 - 20 mA
Air comprimé conforme ISO 8573-1 CLASSE 2
Comprend arcade Inox pour montage sur vérin, entraîneur pour vérin, vis, rondelle.

Type: Electro-pneumatic for double-acting actuator
Service temperature: -30°C/+80°C
Air supply: 1.4 up to 7 bar
Body: Macrolon®
IP66
Display: LCD screen
Input signal: 4-20 mA
Compressed air in accordance with ISO 8573-1 CLASS 2
Includes Stainless steel arch for mounting on the actuator, bolts.



Kit d'adaptation inox inclus avec carters de protection
Stainless steel mounting kit included with protective housing



DN	POSSIE-DE		POSSIE-DE + POSSIE-RECOPIE 4-20MA ^{NEW}		POSSIE-DE + POSSIE-FDC ^{NEW}		POSSIE-DE + POSSIE-RECOPIE 4-20MA + POSSIE-FDC ^{NEW}	
	mm	inch	Ref.	Ref.	Ref.	Ref.	Ref.	Ref.
40-80	1"1/2-3"	300180084	300180085	300200317	300200327			
		Ex 300180086	Ex 300180087	Ex 300200326	Ex 300200332			
100	4"	300180306	300180307	300200318	300200328			
		Ex 300180308	Ex 300180309	Ex 300200322	Ex 300200333			
125-150	5"-6"	300180310	300180311	300200319	300200329			
		Ex 300180312	Ex 300180313	Ex 300200323	Ex 300200334			
200-250	8"-10"	300180314	300180315	300200320	300200330			
		Ex 300180316	Ex 300180317	Ex 300200324	Ex 300200335			
300	12"	300180318	300180319	300200321	300200331			
		Ex 300180320	Ex 300180321	Ex 300200325	Ex 300200336			

RECOPIE : Information du positionnement sur un tableau / Information about positioning information on a board
FDC : Fin de course qui permet d'indiquer visuellement la position / Limit switch visually indicates the position

Ex Zone ATEX / ATEX zone : II 2G Ex ia IIC T6/T4 Gb
II 3G Ex ic IIC T6/T4 Gc

Autres types de protections sur demande / Other protection zone on request

KIT CONTACT FIN DE COURSE XCKM I LIMIT SWITCH KIT

Mécanique | Mechanical

Kit contact fin de course mécanique XCKM115

Mechanical limit switch XCKM115

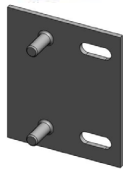

- Composé de :**
- 1 contact fin de course électromécanique
 - 1 connecteur
 - 1 plaque support inox, vis
 - Index de position inox

- Comprised of:**
- 1 electro-mechanical limit switch
 - 1 connector
 - 1 Stainless steel support plate, screws
 - Stainless steel position indicator



DN		1 Contact Ouverture / Open	1 Contact Fermeture / Closed	2 Contacts
mm	inch	Ref.	Ref.	Ref.
50	2"	300180106	300180108	300180109
65	2"1/2	300180107	300180108	300180110
80	3"	300180107	300180108	300180110
100	4"	300180107	300180108	300180110
125	5"	300180107	300180108	300180110
150	6"	300180107	300180108	300180110
200	8"	300180108	300180108	300180111
250	10"	300180108	300180108	300180111
300	12"	300180108	300180108	300180111
350-1200	12"-48"	300200298	300200298	300110013

KIT SUPPORT POUR CFC I MECHANICAL LIMIT SWITCH SUPPORT

Mécanique | Mechanical

Plaque support inox + visserie pour contact fin de course mécanique XCKM

Stainless steel SUP. + screw kit for mechanical limit switch

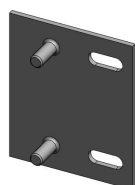

- Composé de :**
- Plaque support inox pour XCKM + vis
 - Index de position inox

- Comprised of:**
- Support plate for limit switches XCKM + screws
 - Stainless steel position index

DN		1 Contact Ouverture / Open	1 Contact Fermeture / Closed	2 Contacts
mm	inch	Ref.	Ref.	Ref.
50	2"	300110042	300110041	300110040
65-150	2"1/2-6"	300110045	300110044	300110043
200-300	8"-12"	300110048	300110047	300110046

CONTACT FIN DE COURSE Ø12MM I LIMIT SWITCH Ø12MM

Inductif | Inductive

Kit contact fin de course inductif Ø12

Inductive sensor Ø12



- Composé de :**
- 1 détecteur inductif télé-mécanique M12 XS612B1PAM12
 - 1 connecteur (XZCP1241L2) + 2m de fil
 - 1 plaque support inox M12 - M18, vis
 - Index de position inox

- Comprised of:**
- 1 contact XS612B1PAM12
 - 1 connector XZCP1241L2 + 2m of cable
 - 1 Stainless steel support plate, screws
 - Stainless steel position index



DN		1 Contact Ouverture / Open	1 Contact Fermeture / Closed	2 Contacts
mm	inch	Ref.	Ref.	Ref.
50	2"	300180102	300180095	300180104
65	2"1/2			
80	3"			
100	4"			
125	5"			
150	6"	300180095		300180097
200-1200	8"			

CONTACT FIN DE COURSE Ø18MM I LIMIT SWITCH Ø18MM

Inductif | Inductive

Kit contact fin de course inductif Ø18

Inductive sensor Ø18



- Composé de :**
- 1 détecteur inductif M18 (IGS204)
 - 1 connecteur coudé Femelle + 2m de fil
 - 1 plaque support inox + écrous
 - Index de position inox

- Comprised of:**
- 1 inductive proximity switch (IGS204)
 - 1 Female connector + 2m of cable
 - 1 Stainless steel support plate + screws
 - Stainless steel position index

DN		1 Contact Ouverture / Open	1 Contact Fermeture / Closed	2 Contacts
mm	inch	Ref.	Ref.	Ref.
50	2"	300180098	300180099	300190321
65	2"1/2			
80	3"			
100	4"			
125	5"			
150	6"	300180099		300180100
200-1200	8"			
				300180101

DÉTECTEURS INDUCTIFS ATEX | ATEX INDUCTIVE LIMIT SWITCH

Détecteur inductif M12 ATEX P+F
Inductive detector M12 ATEX P+F



PEPPERL+FUCHS



Corps : Inox
Diamètre : 12
Portée : 2mm
2 Fils NAMUR
Câble PVC Lg 2m
T° ambiante : -25°C / 100°C
ATEX
IP66 / IP67

Body: Stainless steel
Diam.: 12
Operating distance: 2mm
2 cable NAMUR
PVC cable Length 2m
Ambiente temperature : -25°C / 100°C
ATEX
IP66 / IP67

Ref.
NCB2-12GM35-NO



ATEX 1G Ex ia IIC T6
ATEX 2G Ex ia IIC T6
ATEX 3G Ex ic IIC T6
ATEX 1D Ex ia IIIC T135°C
ATEX 2D Ex ib IIIC T135°C
ATEX 3D Ex tc IIIC T80°C

KIT SUPPORT POUR DÉTECTEURS INDUCTIFS | SUPPORT FOR INDUCTIVE LIMIT SWITCH

Plaque support inox + visserie pour contact fin de course inductif M12-M18
Stainless steel support. + screw kit for inductive M12-M18 limit switch

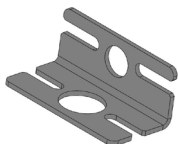

Composé de :
- 1 plaque support Inox 304 + vis
- Index de position inox

Comprised of:
- 1 Stainless steel 304 support plate
+ screws
- Stainless steel position index



DN		1 Contact Ouverture / Open	1 Contact Fermeture / Closed	2 Contacts
mm	inch	Ref.	Ref.	Ref.
50-150	2"-6"	300130026	300130025	300130024
200-300	8"-12"	300130028	300130028	300130027
350-600	14"-24"	300190338	300190338	300130029

RAIL POUR DETECTEUR | SENSOR SUPPORT RAIL

Plaque support pour détecteur inductif M18 pour vanne à guillotine
Support rail for sensor M18 for knife gate valve



Composé de :
1 plaque support Inox 304
Montage directement sur la vanne

Comprised of:
1 Stainless steel 304 support plate
Mounting directly on the valve



DN		Ref.	Nombre max de détecteur Max number of sensors
mm	inch		
50	2"	VGRAIL-0050	3
65	2"1/2	VGRAIL-0065	3
80	3"	VGRAIL-0080	3
100	4"	VGRAIL-0100	4
125	5"	VGRAIL-0125	4
150	6"	VGRAIL-0150	5
200	8"	VGRAIL-0200	6
250	10"	VGRAIL-0250	7
300	12"	VGRAIL-0300	8



Permet le montage de plusieurs contacts inductifs et le positionnement sur la course.
Allows multiple inductive limit switches to be mounted at once and to be positioned along the stroke.

CAPOT DE PROTECTION | SECURITY PROTECTION

Capot de protection pour indicateur de position
Security protection for position indicator



Matière : Inox 316
Material: Stainless steel 316

DN		Ref.	DN		Ref.
mm	inch		mm	inch	
50	2"	VGPROTECIND-IN0050	250	10"	VGPROTECIND-IN0250
65	2"1/2	VGPROTECIND-IN0065	300	12"	VGPROTECIND-IN0300
80	3"	VGPROTECIND-IN0080	350	14"	VGPROTECIND-IN0350
100	4"	VGPROTECIND-IN0100	400	16"	VGPROTECIND-IN0400
125	5"	VGPROTECIND-IN0125	500	20"	VGPROTECIND-IN0500
150	6"	VGPROTECIND-IN0150	600	24"	VGPROTECIND-IN0600
200	8"	VGPROTECIND-IN0200			

DN supérieurs sur demande / Other DN on request

PLAQUES SUPPORT INOX | SUPPORT PLATES

Inox | Stainless steel

Plaques support inox préformées et pré-perçées pour recevoir les contacts fin de course et les électrodistributeurs ASCO®

Stainless steel pre-shaped and pre-drilled support plates for mounting ASCO® limit switches and solenoid valves



Prix pour 2 pièces
 . Sécurise les vannes et protège les contacts fin de course en cas d'ambiance agressive
 . Simplifie le montage d'accessoires du DN50 au 300.

Price for 2 pieces
 . Secure the valves and protect the limit switches.
 . Simplified accessory mounting from DN50 to 300.

JUSQU'À ÉPUISEMENT DES STOCKS
 WHILE STOCKS LAST

DN		Inox 304	Inox 316
mm	inch	Ref.	Ref.
50	2"	VGPLAQSUP-IN0050	VGPLAQSUP316-IN0050
65	2"1/2	VGPLAQSUP-IN0065	VGPLAQSUP316-IN0065
80	3"	VGPLAQSUP-IN0080	VGPLAQSUP316-IN0080
100	4"	VGPLAQSUP-IN0100	VGPLAQSUP316-IN0100
125	5"	VGPLAQSUP-IN0125	VGPLAQSUP316-IN0125
150	6"	VGPLAQSUP-IN0150	VGPLAQSUP316-IN0150
200	8"	VGPLAQSUP-IN0200	VGPLAQSUP316-IN0200
250	10"	VGPLAQSUP-IN0250	VGPLAQSUP316-IN0250
300	12"	VGPLAQSUP-IN0300	VGPLAQSUP316-IN0300
350	14"	VGPLAQSUP-IN0350	VGPLAQSUP316-IN0350
400	16"	VGPLAQSUP-IN0400	VGPLAQSUP316-IN0400
450	18"	VGPLAQSUP-IN0450	VGPLAQSUP316-IN0450
500	20"	VGPLAQSUP-IN0500	VGPLAQSUP316-IN0500
600	24"	VGPLAQSUP-IN0600	VGPLAQSUP316-IN0600
700	28"	VGPLAQSUP-IN0700	
800	32"	VGPLAQSUP-IN0800	
900	36"	VGPLAQSUP-IN0900	
1000	40"	VGPLAQSUP-IN1000	
1200	48"	VGPLAQSUP-IN1200	

NEW

DN supérieurs sur demande / Other DN on request



En cas d'ambiance agressive
 À monter sur les références VG6400 pour une vanne TOUT INOX !
In case of aggressive environments.
 To add to VG6400 range for a fully Stainless steel valve!

PLAQUES | PLATES

Plaques pré-perçées pour support inductif type M18*

Pre-drilled support plates for type M18* inductive sensors

NEW

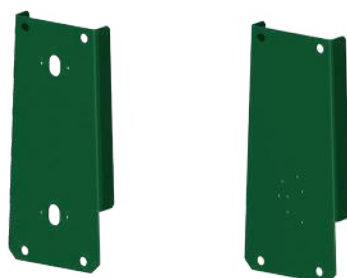

Kit comprenant :
 - 1 plaque support acier carbone (type KL2)
 - 2 plaques de réglage Inox 304 pour contact inductif M18 (ouv.-ferm)

Comprised of:
 - 1 support Steel plate (KL2 type)
 - 2 support Stainless steel 304 plate limit switches M18 (open-close)



DN		Ref.
mm	inch	
50	2"	300200299
65	2"1/2	300200300
80	3"	300200301
100	4"	300200302
125	5"	300200303
150	6"	300200304
200	8"	300200305
250	10"	300200306
300	12"	300200307
350	14"	300200308
400	16"	300200309
450	18"	300210111
500	20"	300200310
600	24"	300200311

DN supérieurs sur demande / Other DN on request
 * Type M12 sur demande / M12 type on request



Idéal en papeterie
 Recommended for the paper industry



Idéal en biogaz (avec le KIT PE spécifique page 140)
 Recommended for biogas industry (add kit biogas on page 140)



L'index de position est protégé sous les plaques.
 The position indicator is protected under the support plates.

CAPOT DE PROTECTION | SECURITY PROTECTION

Capots de protection latéraux Inox 304 seuls
Stainless steel 304 side protections

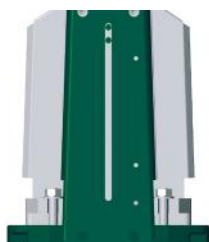

Prix pour 2 pièces (la paire)
Price for 2 pieces (the pair)

DN		Ref.	DN		Ref.
mm	inch		mm	inch	
50	2"	300180175	250	10"	300180182
65	2 1/2"	300180176	300	12"	300180183
80	3"	300180177	350	14"	300180184
100	4"	300180178	400	16"	300180185
125	5"	300180179	450	18"	300180186
150	6"	300180180	500	20"	300180187
200	8"	300180181	600	24"	300180188

DN supérieurs sur demande / Other DN on request



Inox 316 sur demande
Stainless steel 316 on request

CAPOTAGE DE PROTECTION | PROTECTION

Capot de protection détecteur inductif pour vanne à guillotine
Inductive sensor protection kit for knife gate valves



Composé de :
- Capots de protection droit/gauche/central Inox 304
- Indicateur détection Inox 304
- Rail pour Kit + vis
- Support capteur M18

Réglable sur rail des contacts inductifs / Ouverture aisée pour contrôle, protège les contacts contre toutes projections (pâte à papier ...)

Comprised of:
- Protection support detection right/left/face Stainless steel 304
- Indicator Stainless steel 304
- Rail for special detection kit + screws
- Limit switch support M18

Adjustable on rail / Easy opening for inspection, protect limit switches from potential pulp projection

DN		Ref.
mm	inch	
50	2"	300110168
65	2 1/2"	300110169
80	3"	300110170
100	4"	300110171
125	5"	300110172
150	6"	300110173
200	8"	300110174
250	10"	300110175
300	12"	300110176



Idéal en industrie lourde (papèterie ...)
Ideal for heavy industries (paper plant, etc.)



Contact fin de course non compris.
Limit switches not included.

KIT SOUFFLAGE | FLUSHING HOLES

Kit trous de soufflage sur vanne à guillotine VG4400/VG6400
Flushing hole kit for knife gate valve VG4400/VG6400



Prix à ajouter au prix de la VG (VG4400/VG6400)
Disponible en version fonte ou Inox

Price to be added to price of knife gate valve (VG4400/6400)
Available in Ductile iron or Stainless steel



Les trous de soufflage permettent de limiter les accumulations dans les parties basses du corps, donc le coincement de la vanne. Option idéale pour la papèterie ou les mines.

Flushing holes limit the accumulation of debris in hollow areas that could block the valve. An ideal option for the paper and mining industries.

DN		Fonte / Ductile Iron	Inox / Stainless steel
mm	inch	Ref.	Ref.
50	2"	VGKITSOUFFLAGE-0050	VGKITSOUFFLAGEI-0050
65	2 1/2"	VGKITSOUFFLAGE-0065	VGKITSOUFFLAGEI-0065
80	3"	VGKITSOUFFLAGE-0080	VGKITSOUFFLAGEI-0080
100	4"	VGKITSOUFFLAGE-0100	VGKITSOUFFLAGEI-0100
125	5"	VGKITSOUFFLAGE-0125	VGKITSOUFFLAGEI-0125
150	6"	VGKITSOUFFLAGE-0150	VGKITSOUFFLAGEI-0150
200	8"	VGKITSOUFFLAGE-0200	VGKITSOUFFLAGEI-0200
250	10"	VGKITSOUFFLAGE-0250	VGKITSOUFFLAGEI-0250
300	12"	VGKITSOUFFLAGE-0300	VGKITSOUFFLAGEI-0300
350	14"	VGKITSOUFFLAGE-0350	VGKITSOUFFLAGEI-0350
400	16"	VGKITSOUFFLAGE-0400	VGKITSOUFFLAGEI-0400
500	18"	VGKITSOUFFLAGE-0500	VGKITSOUFFLAGEI-0500
600	20"	VGKITSOUFFLAGE-0600	VGKITSOUFFLAGEI-0600
800	24"	VGKITSOUFFLAGE-0800	VGKITSOUFFLAGEI-0800

DN supérieurs sur demande / Other DN on request



Nous préconisons l'installation de système anti-retour pour protéger le système de soufflage. Nous contacter pour tout besoin.
We specify installing an anti-return system to protect the flushing system. Contact us.



Défecteur | Deflector

- ✓ Protège le corps : évite la pénétration du produit dans les zones creuses.
- ✓ Permet la régulation du flux.
- ✓ Canalise le fluide au centre du passage.
- ✓ Protects the Body: prevents penetration of the product in hollow areas.
- ✓ Enables flow regulation.
- ✓ Channels the fluid to the center of the passage.



Notre gamme de déflecteurs TECOFI peut être montée sur nos modèles de vannes à guillotine unidirectionnelles:
Our TECOFI's range of deflectors can be mounted on all unidirectional knife gate valves :

VG3400 / VGA3430 / VG4400 / VGA4430 / VG6400 / VGA6430



Les déflecteurs TECOFI ne peuvent pas être utilisés sur notre gamme de vannes à guillotine sous silo
TECOFI's deflectors cannot be used on our under silo knife gate valves

DEFLECTEUR | DEFLECTOR

Circulaire | Conical

Défecteur circulaire Inox 316 pour vanne à guillotine
Stainless steel 316 conical deflector for knife gate valves



Fonction : Protège le corps

Function: Protects body

DN		Ref.	DN		Ref.
mm	inch		mm	inch	
50	2"	VGDEFLECSTD-0050	400	16"	VGDEFLECSTD-0400
65	2 1/2"	VGDEFLECSTD-0065	450	18"	VGDEFLECSTD-0450
80	3"	VGDEFLECSTD-0080	500	20"	VGDEFLECSTD-0500
100	4"	VGDEFLECSTD-0100	600	24"	VGDEFLECSTD-0600
125	5"	VGDEFLECSTD-0125	700	28"	VGDEFLECSTD-0700
150	6"	VGDEFLECSTD-0150	800	32"	VGDEFLECSTD-0800
200	8"	VGDEFLECSTD-0200	900	36"	VGDEFLECSTD-0900
250	10"	VGDEFLECSTD-0250	1000	40"	VGDEFLECSTD-1000
300	12"	VGDEFLECSTD-0300	1200	48"	VGDEFLECSTD-1200
350	14"	VGDEFLECSTD-0350			



Prévoir un joint entre le corps et le déflecteur pour l'étanchéité, voir page 321.
Use gasket between body and deflector for tightness, see on page 321.

DEFLECTEUR | DEFLECTOR

Triangulaire | Triangular

Défecteur conique triangulaire Inox 316 pour vanne à guillotine
Stainless steel 316 triangular conical deflector for knife gate valves



Fonction : Protège le corps et permet la régulation du flux

Function: Protects body and allows flow regulation

DN		Ref.	DN		Ref.
mm	inch		mm	inch	
50	2"	VGDEFLECTRI-0050	400	16"	VGDEFLECTRI-0400
65	2 1/2"	VGDEFLECTRI-0065	450	18"	VGDEFLECTRI-0450
80	3"	VGDEFLECTRI-0080	500	20"	VGDEFLECTRI-0500
100	4"	VGDEFLECTRI-0100	600	24"	VGDEFLECTRI-0600
125	5"	VGDEFLECTRI-0125	700	28"	VGDEFLECTRI-0700
150	6"	VGDEFLECTRI-0150	800	32"	VGDEFLECTRI-0800
200	8"	VGDEFLECTRI-0200	900	36"	VGDEFLECTRI-0900
250	10"	VGDEFLECTRI-0250	1000	40"	VGDEFLECTRI-1000
300	12"	VGDEFLECTRI-0300	1200	48"	VGDEFLECTRI-1200
350	14"	VGDEFLECTRI-0350			



Prévoir un joint entre le corps et le déflecteur pour l'étanchéité, voir page 321.
Use gasket between body and deflector for tightness, see on page 321.

DEFLECTEUR | DEFLECTOR

En "V" | "V"

Défecteur conique en "V" Inox 316 - 90° pour vanne à guillotine
Stainless steel 316 "V" 90° conical deflector for knife gate valves



Fonction : Protège le corps et permet la régulation du flux

Function: Protects body and allows flow regulation

DN		Ref.	DN		Ref.
mm	inch		mm	inch	
50	2"	VGDEFLECV90-0050	400	16"	VGDEFLECV90-0400
65	2 1/2"	VGDEFLECV90-0065	450	18"	VGDEFLECV90-0450
80	3"	VGDEFLECV90-0080	500	20"	VGDEFLECV90-0500
100	4"	VGDEFLECV90-0100	600	24"	VGDEFLECV90-0600
125	5"	VGDEFLECV90-0125	700	28"	VGDEFLECV90-0700
150	6"	VGDEFLECV90-0150	800	32"	VGDEFLECV90-0800
200	8"	VGDEFLECV90-0200	900	36"	VGDEFLECV90-0900
250	10"	VGDEFLECV90-0250	1000	40"	VGDEFLECV90-1000
300	12"	VGDEFLECV90-0300	1200	48"	VGDEFLECV90-1200
350	14"	VGDEFLECV90-0350			



Prévoir un joint entre le corps et le déflecteur pour l'étanchéité, voir page 321.
Use gasket between body and deflector for tightness, see on page 321.





Nos différents modèles de pelle en option :
Nous préconisons un montage de pelle traitée sur les corps acier / acier inoxydable pour plus d'efficacité.

✓ **Une résistance accrue face à l'abrasion et la corrosion**

PELLE TRANCHANTE EN INOX 304 / 316L

Usinée et polie pour une fermeture sans blocage.

PELLE POLIE MIROIR (OPTION)

Evite l'accroche des produits sur la pelle.

PELLE DURCIE (OPTION)

Traitement à cœur HARDOX® (traitement dur pour résister à l'abrasion, sable, cimenterie), traitement de surface ou acier Superduplex (idéal pour eau de mer), pour renforcer la dureté de la pelle (option). Rallonge la durée de vie du produit. Résiste aux chocs (par exemple en sortie de pulpeur pour la papeterie). Lutte contre la corrosion.

Nuances de différentes matières disponibles, nous consulter pour des applications spéciales (corps, pelle Duplex, Superduplex ...).



Our different optional knife models:
We recommend mounting a treated gate with a steel/stainless steel body for better efficiency.

✓ **Enhanced resistance against abrasion and corrosion**

STAINLESS STEEL 304 CUTTING GATE / 316L

Machined and polished for closure without blockage.

MIRROR-POLISHED GATE (OPTION)

Prevents products from sticking to the gate (option).

HARDENED VG GATE (OPTION)

HARDOX® core treatment (treatment to resist sand and cement abrasions), surface treatment or Superduplex steel (ideal for seawater), to reinforce the hardness of the gate (option). Lengthen the lifespan of the product. Resistant to shocks (for example at the exit of pulpers in the paper industry). Fights against corrosion.

Different material grades available, consult us for special applications (body, Duplex gate, Superduplex ...).

PELLE INOX 304 | STAINLESS STEEL 304 GATE

Pelle Inox 304 pour vanne à guillotine VG4400
Stainless steel 304 gate for knife gate valves



**JUSQU'A ÉPUISEMENT DES STOCKS
WHILE STOCKS LAST**

Pour plus d'efficacité, nous améliorons notre offre et proposons les pelles en 316L en standard pour toute rechange. Celles-ci sont disponibles jusqu'à épuisement. *DN non disponible en 304, voir le modèle en 316L

For more efficiency, we are offering 316L gates for any standard replacement while supplies last. *DN not available in 304, see model in 316L

DN		Ref.	DN		Ref.
mm	inch		mm	inch	
50	2"	VGPELLE304-0050	250	10"	VGPELLE304-0250
65	2 1/2"	VGPELLE304-0065	300	12"	VGPELLE304-0300
80	3"	VGPELLE304-0080	350	14"	VGPELLE304-0350
100*	4"	VGPELLE304-0100	400	16"	VGPELLE304-0400
125	5"	VGPELLE304-0125	450	18"	VGPELLE304-0450
150	6"	VGPELLE304-0150	500	20"	VGPELLE304-0500
200	8"	VGPELLE304-0200	600	24"	VGPELLE304-0600

PELLE INOX 316L | STAINLESS STEEL 316L GATE

Pelle Inox 316L pour vanne à guillotine VG4400 / VG6400
Stainless steel 316L gate for knife gate valves



DN		Ref.	DN		Ref.
mm	inch		mm	inch	
50	2"	VGPELLE316-0050	400	16"	VGPELLE316-0400
65	2 1/2"	VGPELLE316-0065	450	18"	VGPELLE316-0450
80	3"	VGPELLE316-0080	500	20"	VGPELLE316-0500
100	4"	VGPELLE316-0100	600	24"	VGPELLE316-0600
125	5"	VGPELLE316-0125	700	28"	VGPELLE316-0700
150	6"	VGPELLE316-0150	800	32"	VGPELLE316-0800
200	8"	VGPELLE316-0200	900	36"	VGPELLE316-0900
250	10"	VGPELLE316-0250	1000	40"	VGPELLE316-1000
300	12"	VGPELLE316-0300	1200	48"	VGPELLE316-1200
350	14"	VGPELLE316-0350			



Avec un produit très collant, nous préconisons d'ajouter un racleur page 136 pour une pelle propre et sans remontées.
For use with very sticky products, we recommend adding a scraper on page 136 to maintain a clean gate without dirt.

RACLEUR | SCRAPER

Racleur Inox 304 pour vanne à guillotine VG4400/VG6400
 Scraper for knife gate valve Stainless steel 304 VG4400/VG6400



Matière : Inox 304
 Installé au niveau du fouloir pour VG4400 / VG6400.

Material: Stainless steel 304
 To be installed at packing gland level for VG4400 / VG6400.

Autres nuances sur demande
Other materials on request

DN		Ref.
mm	inch	
50	2"	VGRACLEUR-0050
65	2"1/2	VGRACLEUR-0065
80	3"	VGRACLEUR-0080
100	4"	VGRACLEUR-0100
125	5"	VGRACLEUR-0125
150	6"	VGRACLEUR-0150
200	8"	VGRACLEUR-0200
250	10"	VGRACLEUR-0250
300	12"	VGRACLEUR-0300
350	14"	VGRACLEUR-0350
400	16"	VGRACLEUR-0400
450	18"	VGRACLEUR-0450
500	20"	VGRACLEUR-0500
600	24"	VGRACLEUR-0600

DN supérieurs sur demande / Other DN on request
 Racleurs différents pour VGB / Different model scraper for VGB

Élimine les particules collées sur la pelle des deux côtés
Removes particles stuck to both sides of the gate

JOINT DE SIÈGE | SEAT GASKET

Joint de siège pour vanne à guillotine standard VG4400/VG6400
 Seat gasket for standard knife gate valve VG4400/VG6400



Prix indiqué pour le joint seul, sans montage

Price for gasket only without assembly

DN		Joint / Gasket EPDM T° maxi : 130°C	Joint / Gasket NBR T° maxi : 80°C	Joint / Gasket FPM T° maxi : 170°C	Bague / Ring PTFE T° maxi : 170°C (étanchéité relative / Relative tightness)
mm	inch	Ref.	Ref.	Ref.	Ref.
50	2"	VGJOINTMOU-EP0050	VGJOINTMOU-NI0050	VGJOINTMOU-VI0050	VGJOINTMOU-PTF0050
65	2"1/2	VGJOINTMOU-EP0065	VGJOINTMOU-NI0065	VGJOINTMOU-VI0065	VGJOINTMOU-PTF0065
80	3"	VGJOINTMOU-EP0080	VGJOINTMOU-NI0080	VGJOINTMOU-VI0080	VGJOINTMOU-PTF0080
100	4"	VGJOINTMOU-EP0100	VGJOINTMOU-NI0100	VGJOINTMOU-VI0100	VGJOINTMOU-PTF0100
125	5"	VGJOINTMOU-EP0125	VGJOINTMOU-NI0125	VGJOINTMOU-VI0125	VGJOINTMOU-PTF0125
150	6"	VGJOINTMOU-EP0150	VGJOINTMOU-NI0150	VGJOINTMOU-VI0150	VGJOINTMOU-PTF0150
200	8"	VGJOINTMOU-EP0200	VGJOINTMOU-NI0200	VGJOINTMOU-VI0200	VGJOINTMOU-PTF0200
250	10"	VGJOINTMOU-EP0250	VGJOINTMOU-NI0250	VGJOINTMOU-VI0250	VGJOINTMOU-PTF0250
300	12"	VGJOINTMOU-EP0300	VGJOINTMOU-NI0300	VGJOINTMOU-VI0300	VGJOINTMOU-PTF0300
350	14"	VGJOINTMOU-EP0350	VGJOINTMOU-NI0350	VGJOINTMOU-VI0350	VGJOINTMOU-PTF0350
400	16"	VGJOINTMOU-EP0400	VGJOINTMOU-NI0400	VGJOINTMOU-VI0400	VGJOINTMOU-PTF0400
450	18"	VGJOINTMOU-EP0450	VGJOINTMOU-NI0450	VGJOINTMOU-VI0450	VGJOINTMOU-PTF0450
500	20"	VGJOINTMOU-EP0500	VGJOINTMOU-NI0500	VGJOINTMOU-VI0500	VGJOINTMOU-PTF0500
600	24"	VGJOINTMOU-EP0600	VGJOINTMOU-NI0600	VGJOINTMOU-VI0600	VGJOINTMOU-PTF0600
700	28"	VGJOINTMOU-EP0700	VGJOINTMOU-NI0700	VGJOINTMOU-VI0700	
800	32"	VGJOINTMOU-EP0800	VGJOINTMOU-NI0800	VGJOINTMOU-VI0800	
900	36"	VGJOINTMOU-EP0900	VGJOINTMOU-NI0900	VGJOINTMOU-VI0900	
1000	40"	VGJOINTMOU-EP1000	VGJOINTMOU-NI1000	VGJOINTMOU-VI1000	
1200	48"	VGJOINTMOU-EP1200	VGJOINTMOU-NI1200	VGJOINTMOU-VI1200	

Pour optimiser votre changement de joint de siège, pensez également à la frette Inox
To optimize seat gasket replacement, think of also adding a Stainless steel support ring

VANNE À GUILLOTINE
KNIFE GATE VALVE

FRETTE INOX | STAINLESS STEEL SUPPORT RING

Frette Inox 316 pour joint de siège pour vanne à guillotine standard VG4400/VG6400
Stainless steel 316 support ring for seat gasket for standard knife gate valves



Pour optimiser votre changement de joint, il est conseillé de changer également la frette. To optimize your seat gasket replacement, change also the support ring.



Chanfrein côté intérieur
Beveled inside



DN		Ref.	DN		Ref.
mm	inch		mm	inch	
50	2"	VG FRETTE-0050	400	16"	VG FRETTE-0400
65	2 1/2"	VG FRETTE-0065	450	18"	VG FRETTE-0450
80	3"	VG FRETTE-0080	500	20"	VG FRETTE-0500
100	4"	VG FRETTE-0100	600	24"	VG FRETTE-0600
125	5"	VG FRETTE-0125	700	28"	VG FRETTE-0700
150	6"	VG FRETTE-0150	800	32"	VG FRETTE-0800
200	8"	VG FRETTE-0200	900	36"	VG FRETTE-0900
250	10"	VG FRETTE-0250	1000	40"	VG FRETTE-1000
300	12"	VG FRETTE-0300	1200	48"	VG FRETTE-1200
350	14"	VG FRETTE-0350			

JOINT DE SIÈGE POUR VGB | VGB SEAT GASKET

Joint de siège pour vanne à guillotine bidirectionnelle VGB
Seat gasket for bidirectional knife gate valve



Prix indiqué pour le joint seul, sans montage

Price for gasket only without assembly

DN		EPDM T° maxi : 130°C	NBR T° maxi : 90°C
mm	inch	Ref.	Ref.
50	2"	VGBNJOINT-EP0050	VGBNJOINT-NI0050
65	2 1/2"	VGBNJOINT-EP0065	VGBNJOINT-NI0065
80	3"	VGBNJOINT-EP0080	VGBNJOINT-NI0080
100	4"	VGBNJOINT-EP0100	VGBNJOINT-NI0100
125	5"	VGBNJOINT-EP0125	VGBNJOINT-NI0125
150	6"	VGBNJOINT-EP0150	VGBNJOINT-NI0150
200	8"	VGBNJOINT-EP0200	VGBNJOINT-NI0200
250	10"	VGBNJOINT-EP0250	VGBNJOINT-NI0250
300	12"	VGBNJOINT-EP0300	VGBNJOINT-NI0300
350	14"	VGBNJOINT-EP0350	VGBNJOINT-NI0350
400	16"	VGBNJOINT-EP0400	VGBNJOINT-NI0400

DN supérieurs sur demande / Other DN on request

VG FOULOIR FONTE | CAST IRON PACKING

Fouloir de presse étoupe fonte ductile
Ductile Iron packing gland



Matière : Fonte GS GGG40

Material: Ductile Iron GGG40

Fonte ductile | Ductile Iron

DN		Ref.	DN		Ref.
mm	inch		mm	inch	
50	2"	VGFOULOIRFONTE-0050	400	16"	VGFOULOIRFONTE-0400
65	2 1/2"	VGFOULOIRFONTE-0065	450	18"	VGFOULOIRFONTE-0450
80	3"	VGFOULOIRFONTE-0080	500	20"	VGFOULOIRFONTE-0500
100	4"	VGFOULOIRFONTE-0100	600	24"	VGFOULOIRFONTE-0600
125	5"	VGFOULOIRFONTE-0125	700	28"	VGFOULOIRFONTE-0700
150	6"	VGFOULOIRFONTE-0150	800	32"	VGFOULOIRFONTE-0800
200	8"	VGFOULOIRFONTE-0200	900	36"	VGFOULOIRFONTE-0900
250	10"	VGFOULOIRFONTE-0250	1000	40"	VGFOULOIRFONTE-1000
300	12"	VGFOULOIRFONTE-0300	1200	48"	VGFOULOIRFONTE-1200
350	14"	VGFOULOIRFONTE-0350			

VG FOULOIR INOX I SS PACKING GLAND

Inox 316 | Stainless steel 316

Fouloir de presse étoupe Inox 316
Stainless steel 316 packing gland



Matière : Inox 316

Material: Stainless steel 316

DN		Ref.	DN		Ref.
mm	inch		mm	inch	
50	2"	VGFOULOIRINOX-0050	400	16"	VGFOULOIRINOX-0400
65	2"1/2	VGFOULOIRINOX-0065	450	18"	VGFOULOIRINOX-0450
80	3"	VGFOULOIRINOX-0080	500	20"	VGFOULOIRINOX-0500
100	4"	VGFOULOIRINOX-0100	600	24"	VGFOULOIRINOX-0600
125	5"	VGFOULOIRINOX-0125			
150	6"	VGFOULOIRINOX-0150			
200	8"	VGFOULOIRINOX-0200			
250	10"	VGFOULOIRINOX-0250			
300	12"	VGFOULOIRINOX-0300			
350	14"	VGFOULOIRINOX-0350			

KIT PRESSE ETOUPE I PACKING KIT

Kit de rechange presse étoupe VG4400 I VG6400
Kit for packing gland for VG4400 I VG6400



Standard VG4400 - VGKITPE-F

Standard VG6400 - VGKITPE-I

2 tresses PTFE - 1 torique NBR
2 PTFE packing - 1 NBR O-ring
T° -10°C/+80°C

2 tresses PTFE - 1 torique EPDM
2 PTFE packing - 1 EPDM O-ring
T° -10°C/+130°C

DN		Ref.	Ref.
mm	inch		
50	2"	VGKITPE-F0050	VGKITPE-I0050
65	2"1/2	VGKITPE-F0065	VGKITPE-I0065
80	3"	VGKITPE-F0080	VGKITPE-I0080
100	4"	VGKITPE-F0100	VGKITPE-I0100
125	5"	VGKITPE-F0125	VGKITPE-I0125
150	6"	VGKITPE-F0150	VGKITPE-I0150
200	8"	VGKITPE-F0200	VGKITPE-I0200
250	10"	VGKITPE-F0250	VGKITPE-I0250
300	12"	VGKITPE-F0300	VGKITPE-I0300
350	14"	VGKITPE-F0350	VGKITPE-I0350
400	16"	VGKITPE-F0400	VGKITPE-I0400
450	18"	VGKITPE-F0450	VGKITPE-I0450
500	20"	VGKITPE-F0500	VGKITPE-I0500
600	24"	VGKITPE-F0600	VGKITPE-I0600
700	28"	VGKITPE-F0700	-
800	32"	VGKITPE-F0800	-
900	36"	VGKITPE-F0900	-
1000	40"	VGKITPE-F1000	-
1200	48"	VGKITPE-F1200	-



KIT PRESSE ETOUPE HEPHAISTOS | HEPHAISTOS PACKING KIT

Kit presse étoupe avec tresse Héphaïstos - Haute température

Kit of Hephaisstos packing - High temperature



3 tresses héphaïstos (+ 825°C)

Attention T°C relative au corps de la vanne
VG4400 Fonte

Pression de service maxi:
DN50-450 : 5,5 bar
DN500-600 : 4 bar
DN700-1200 : 2 bar
Température de service maxi : 0°C / +350°C

VG6400 Inox

Pression de service maxi:
DN50-450 : 5,6 bar
DN500-600 : 4 bar
Température de service maxi : 0°C / +600°C

3 hephaistos packing (+ 825°C)

Caution T°C relative to the valve body

VG4400 Ductile iron

Max working pressure:
DN50-450 : 5,5 bar
DN500-600 : 4 bar
DN700-1200 : 2 bar
Max working temperature : 0°C / +350°C

VG6400 Stainless steel

Max working pressure:
DN50-450 : 5,6 bar
DN500-600 : 4 bar
Max working temperature : 0°C / +600°C



DN		Ref.	DN		Ref.
mm	inch		mm	inch	
50	2"	300110338	500	20"	300110350
65	2"1/2	300110339	600	24"	300110351
80	3"	300110340	700*	28"	300210037
100	4"	300110341	800*	32"	300210038
125	5"	300110342	900*	36"	300210039
150	6"	300110343	1000*	40"	300210040
200	8"	300110344	1200*	48"	300210041
250	10"	300110345			
300	12"	300110346			
350	14"	300110347			
400	16"	300110348			
450	18"	300110349			

A partir du DN600 kits valables pour VG4400 uniquement
From DN600 kits valid for VG4400 only

KIT PRESSE ETOUPE ACS | ACS PACKING KIT

ACS

Kit presse étoupe avec tresse alimentaire ACS

Kit for food-grade packing gland ACS



2 tresses alimentaires ACS
1 joint de siège EPDM ACS
Température de service : -10°C/+ 80°C

2 ACS food-grade packing glands
1 EPDM ACS seal
Working temperature: -10°C/+ 80°C



ACS pour Eau Potable
ACS certification for Drinking Water

DN		Ref.
mm	inch	
50	2"	300200244
65	2"1/2	300200245
80	3"	300200246
100	4"	300200247
125	5"	300200248
150	6"	300200249
200	8"	300200250
250	10"	300200251
300	12"	300200252
350	14"	300200253
400	16"	300200254
450	18"	300200255
500	20"	300200256
600	24"	300200257

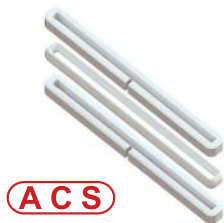

ACS



TRESSE AVEC JOINT FPM | FPM PACKING KIT

Kit presse étoupe avec joint FPM pour VG4400 / VG6400
Kit of FPM packing for VG4400 / VG6400



2 tresses PTFE + 1 torique FPM

2 PTFE packing + 1 FPM O-ring

DN		Ref.	DN		Ref.
mm	inch		mm	inch	
50	2"	300110394	400	16"	300110404
65	2"1/2	300110395	450	18"	300110405
80	3"	300110396	500	20"	300110406
100	4"	300110397	600	24"	300110407
125	5"	300110398	700	28"	300210032
150	6"	300110399	800	32"	300210033
200	8"	300110400	900	36"	300210034
250	10"	300110401	1000	40"	300210035
300	12"	300110402	1200	48"	300210036
350	14"	300110403			

KIT TRESSE POUR VGB | PACKING FOR VGB

Kit presse étoupe pour VGB
Kit of packing for VGB



3 tresses PTFE

3 PTFE packing



DN		Ref. VGB
mm	inch	
50	2"	300200005
65	2"1/2	300200006
80	3"	300200007
100	4"	300200008
125	5"	300200009
150	6"	300200010
200	8"	300200011
250	10"	300200012
300	12"	300200013
350	14"	300200014
400	16"	300200015

TRESSE POUR APPLICATIONS BIOGAZ POUR VGB | PACKING FOR BIOGAS APPLICATIONS FOR VGB

Kit presse étoupe pour application biogaz pour VGB
Kit of packing for biogas applications for VGB



Spécial biogaz
For biogas applications



Kit de 3 tresses renforcées en fibres Aramide

Packing reinforced with Aramide fibers

Application BIOGAZ pour une performance maximale :

- excellente tenue mécanique
- bonne résistance sur fluides abrasifs
- auto lubrifiante
- tresse exempte de silicone

Biogas application for maximum performance:

- excellent mechanical strength
- good resistance to abrasive fluids
- self-lubricating
- packing silicone-free



DN		Ref. VGB BIOGAZ
mm	inch	
50	2"	300180293
65	2"1/2	300180294
80	3"	300180295
100	4"	300180296
125	5"	300180297
150	6"	300180298
200	8"	300180299
250	10"	300180300
300	12"	300180301
350	14"	300190312
400	16"	300190313



Tresse inférieure renforcée avec effet racleur
Lower packing doubles as a scraper



KIT COLONNETTE DROITE POUR VG*

PEDESTAL FLOOR MOUNTED KIT FOR KNIFE GATE VALVE*



Kit à utiliser avec les vannes à guillotine
VG4400-051 - Page 100
VG6400-051 - Page 113

Kit to use with knife gate valve
VG4400-051 - Page 100
VG6400-051 - Page 113

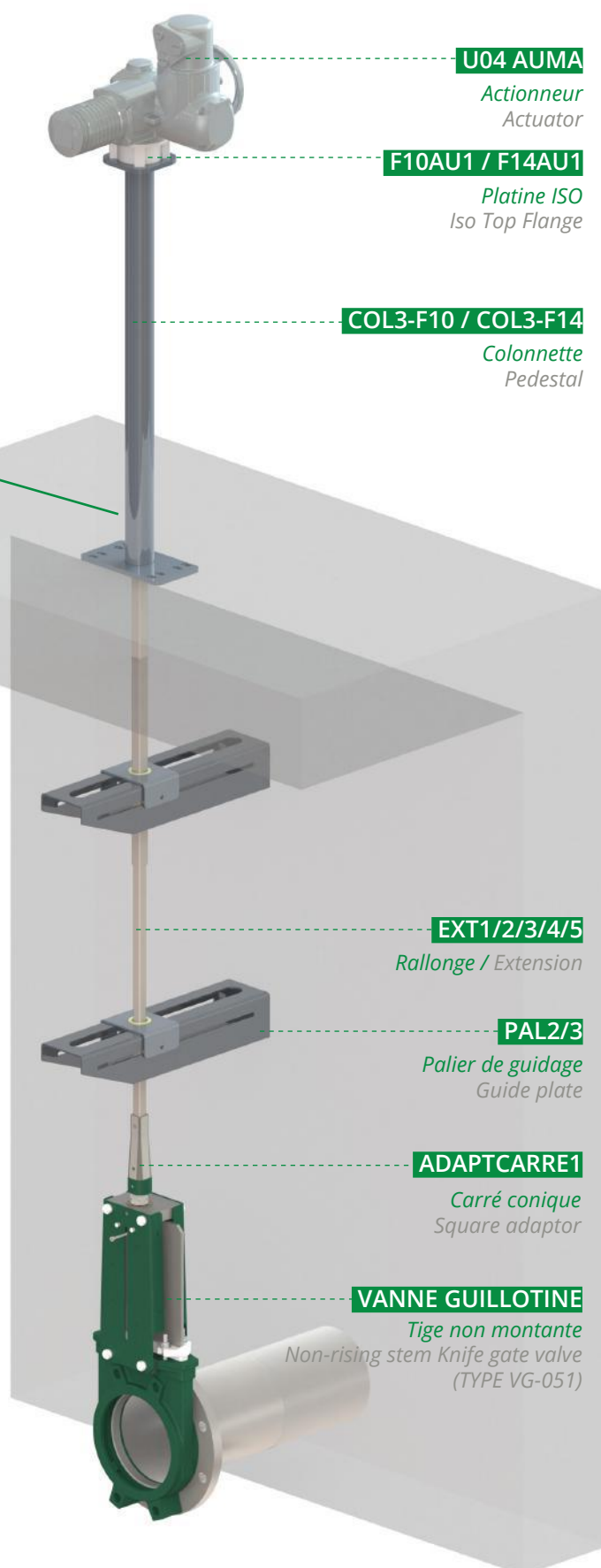

Représentation à titre indicatif (contre-bridés et tirants non représentés, ils sont obligatoires dans toutes installations).
 Representation for reference only (counter flanges and tie rods not shown are required in all installations).

KIT COLONNETTE MURALE POUR VG*

PEDESTAL WALL MOUNTED KIT FOR KNIFE GATE VALVE*

À VOLANT | WITH HANDWHEEL



Kit à utiliser avec les vannes à guillotine

VG4400-051 - Page 100

VG6400-051 - Page 113

Kit to use with knife gate valve

VG4400-051 - Page 100

VG6400-051 - Page 113



La distance entre le mur et les colonnettes murales n'est pas réglable, prévoir un déport avec le mur ou un système pour plaquer la colonnette à la bonne distance.
The distance between the wall and the wall column is not adjustable, provide an offset with the wall or a system to place the column at the right distance.

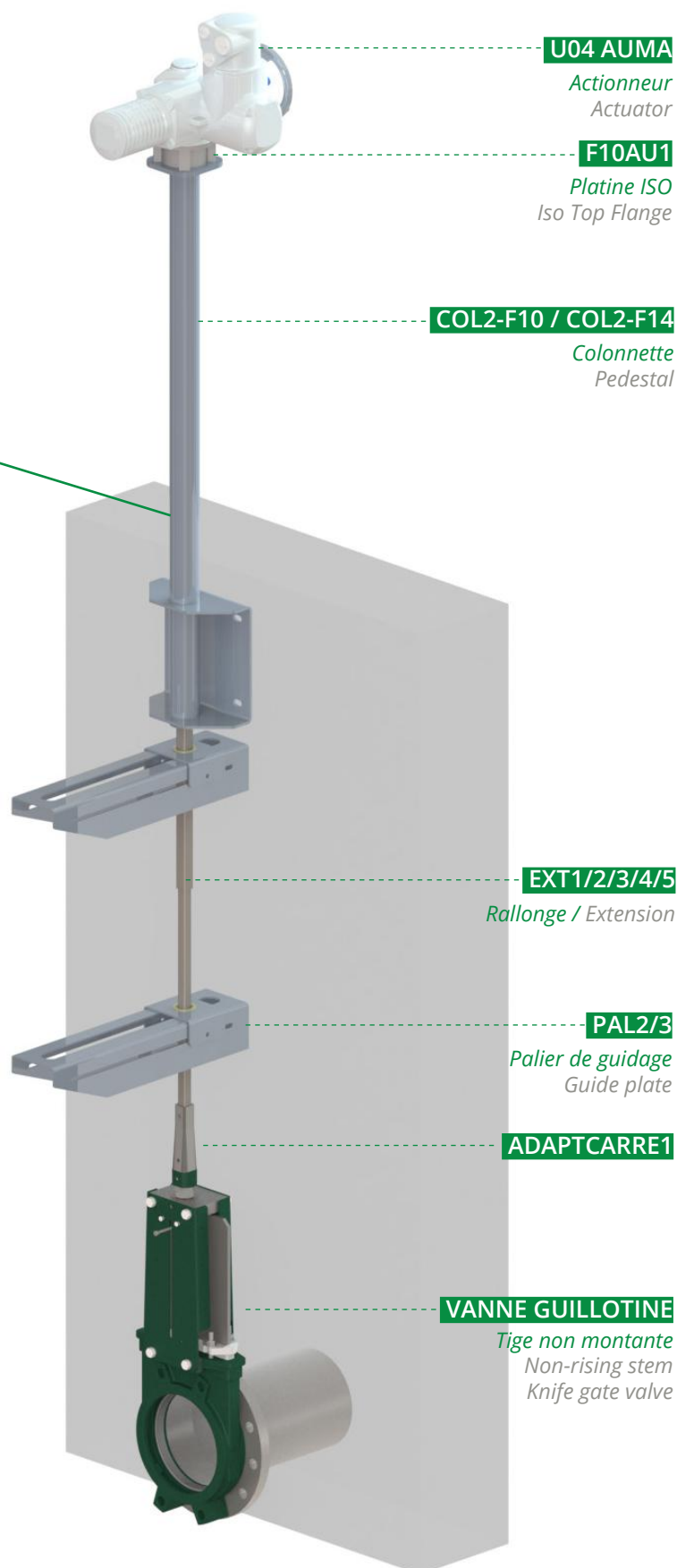

Représentation à titre indicatif (contre-bridés et tirants non représentés, ils sont obligatoires dans toutes installations).
Representation for reference only (counter flanges and tie rods not shown are required in all installations).





TRINGLIERIES POUR MONTAGE SUR COLONNETTE LINKAGE FOR PEDESTAL MOUNTING

CARRÉ DE FONTAINIER CONIQUE | SQUARE ADAPTOR

Carré de manœuvre pour vanne à guillotine tige non montante
Square adaptor for non-rising stem knife gate valve



Matière : Fonte FT25
Dimensions : 30x30

Material: Cast Iron FT25
Dimensions: 30x30

DN		Ref.
mm	inch	
50-150	2"-6"	VGCARRENM1
200-300	8"-12"	VGCARRENM2
350-400	14"-16"	VGCARRENM3

DN supérieurs sur demande / Other DN on request

CLE DE FONTAINIER | HYDRANT KEY

Clé de fontainier
Hydrant key

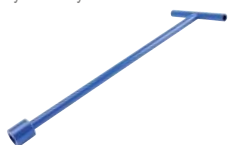

Matière : Acier
Carré : 30mm

Material: Steel
Square: 30mm

L	Ref.
1M	VOCLEWRENCH-1.0ML



Avec embout universel pour carré de manœuvre
With universal end for operating square

CARRÉ CONIQUE | SQUARE ADAPTOR

Pour adaptation de carré conique à rallonge EXT
Square 30x30 adaptor for EXT extension



Matière : Inox 304

Material: Stainless steel 304

Ref.
ADAPTCARRE1

RALLONGE | EXTENSION

Rallonge télescopique
Telescopic extension



Matière : 316L

Material: 316L

Dimension (mm)	Ref.
800 - 1100	EXT1
1100 - 1750	EXT2
1750 - 3000	EXT3
3000 - 5500	EXT4
4000-8000	EXT5



Ajouter la dimension B du passeport technique VG3400-051 pour la distance du centre de la tuyauterie à la manœuvre.

Add the dimension B from the VG3400-051 technical sheet for the distance of the pipe axis to the actuator

PALIER DE GUIDAGE | GUIDE PLATE

Palier de guidage fixe pour rallonge télescopique
Guide plate bearing for telescopic extension EXT



Matière : Inox 316L

Material: Stainless steel 316L

Dimension (mm)	Ref.
70-200	PAL2
70-500	PAL3



Mettre obligatoirement un palier tous les deux mètres + un autre avant le passage dans la colonnette.
Place one guide every two meters of the extension + one guide plate just before the pedestal floor.

COLONNETTES | PEDESTAL

Colonette pour vanne murale
Pedestal for penstock

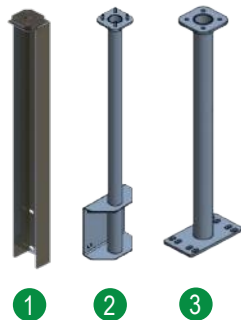

- COL1 : pour commande par volant et fixation murale
- COL2-F10 : pour commande motorisée (F10) et fixation murale
- COL3-F10 : pour commande motorisée (F10) et fixation au sol
- COL3-F14 : pour commande motorisée (F14) et fixation au sol

Matière : Inox 304
Hauteur : 900mm

- Pedestal wall mounted for handwheel
- Pedestal wall mounted for Auma actuator (F10)
- Pedestal wall mounted for Auma actuator (F14)
- Pedestal floor mounted for Auma actuator (F10)
- Pedestal floor mounted for Auma actuator (F14)

Material: Stainless steel 304
Height: 900mm

Ref.
COL1
COL2-F10
COL2-F14
COL3-F10
COL3-F14

PLAQUE DE GUIDAGE | SUPPORT PLATE

Guidage pour volant adaptable sur colonnette COL2-F10 / COL3-F10 (uniquement)
Support plate for handwheel adaptable for COL2-F10 / COL3-F10



Matière : POM

Material: POM

Ref.
GUICOL

VOLANT | HANDWHEEL

Volant
Handwheel



Matière : Acier revêtu Epoxy
Diamètre : 300mm

Material: Epoxy-coated carbon steel
Diameter: 300mm

DN	Ref.
50-300	VOL1
350-400	VOL2

PLATINE POUR MOTEUR | MOTOR PLATE

Platine pour moteur Auma
Support plate for Auma actuator

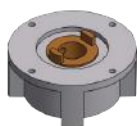

Matière : Acier
Platine : ISO5210
Pour montage sur extension «EXT»

Material: Carbon steel
Top mounted flange: ISO5210
For telescopic extension mounting «EXT»

DN		Ref.
mm	inch	
50-400	2" - 16"	F10AU1

DN supérieurs nous consulter
Other DN on request

U04 - MOTEUR VG - COLONNETTE MURALE | U04 AUMA ACTUATOR FOR PEDESTAL MOUNTING

Motorisation Auma 3 phases 400V/50Hz On/Off
3-phase Auma actuator 400V/50Hz On/Off



Moteur équipé de :
- 2 contacts fin de course
- 1 résistance de chauffe
- 2 limiteurs de couple
Commande manuelle de secours
Indicateur visuel de position
Protection IP68

Actuator equipped:
- 2 limit switches
- 1 heat resistor
- 2 torque limiters switches
Emergency handwheel
Visual position indicator
IP68 protection

DN		Ref.
mm	inch	
50-100	2" - 4"	SA07.2-U04B1TOR63
125-200 300	5" - 10"	SA07.6-U04B1TOR63
250-350-400	12" - 16"	SA10.2-U04B1TOR63

DN supérieurs sur demande / Other DN on request
Moteur modèle platine F10 / Actuator plate model F10



VANNES
À GUILLOTINE
TECOFI[®]
KNIFE GATE
VALVES

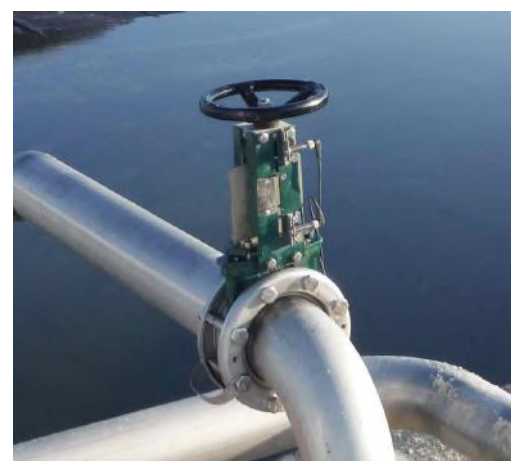

VANNE MURALE

PENSTOCK VALVE

CARACTÉRISTIQUES

- Utilisable pour installations d'entrée et de sortie de bassin
- Adapté pour le sectionnement et la régulation
- Étanchéité 4 côtés
- Faible couple
- Joint entièrement extrudé

Dimensions : 200x200 jusqu'à 1000x1000 en stock

Autres constructions et dimensions sur demande

CHARACTERISTICS

- Usable for installation at inlets and outlets of chambers and basins
- Suitable for ON/OFF and regulating purposes
- Watertight on 4 sides
- Low torque
- Extruded seal

Dimensions: 200x200 up to 1000x1000 available

Other constructions and dimensions on request

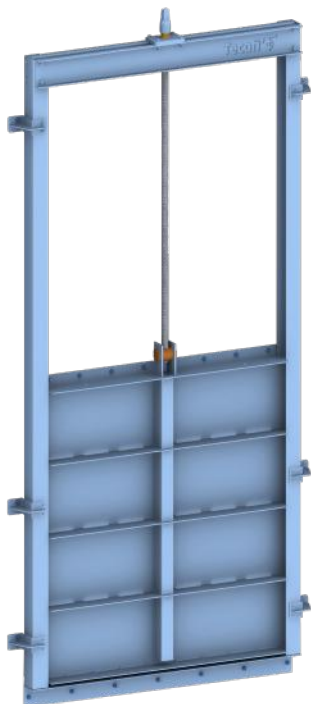

Grand diamètre
Large diameter



Tige non montante
Non-rising stem



Vanne de déverse
Spillway penstock



Traitement d'eau, rejet fluvial, irrigation, barrage
Water treatment, river discharges, irrigation, dam

PRODUIT ASSOCIÉ | TO COMPLETE

Retrouvez nos clapets d'extrémité page 179
Find our terminal check valves on page 179



Nous fournissons les chevilles chimiques utiles pour le montage. Installation et mise en œuvre aisées !
We supply chemical anchors useful for assembly. An all-inclusive and easy installation!



VGM6205A-00 | VGM6206A-00

Vanne murale inox
Penstock in Stainless steel



Corps : voir tableau
Pelle : Inox 304 à 316L
Joint : EPDM
Étanchéité : 4 côtés bidirectionnel
Pression : 6 mCE
Tige non montante en inox 304 ou 316L selon le modèle choisi (voir tableau)

Autres dimensions sur demande

Body: see table
Gate: Stainless steel 304 to 316L
Joint: EPDM
Tightness: 4 sides bidirectional
Pressure: 6 WC
Non-rising stem in 304 or 316L
Stainless steel according on the chosen model (see table)
Other sizes on request

Dim.	Inox 304 Stainless steel 304	Inox 316L Stainless steel 316L
	Ref.	Ref.
200x200	VGM6205A-00EP0200	VGM6206A-00EP0200
300x300	VGM6205A-00EP0300	VGM6206A-00EP0300
400x400	VGM6205A-00EP0400	VGM6206A-00EP0400
500x500	VGM6205A-00EP0500	VGM6206A-00EP0500
600x600	VGM6205A-00EP0600	VGM6206A-00EP0600
700x700	VGM6205A-00EP0700	VGM6206A-00EP0700
800x800	VGM6205A-00EP0800	VGM6206A-00EP0800
900x900	VGM6205A-00EP0900	VGM6206A-00EP0900
1000x1000	VGM6205A-00EP1000	VGM6206A-00EP1000





MONTAGE SUR CADRE
PENSTOCK - FRAME MOUNTED

Commande par carré de manœuvre

Square top on frame

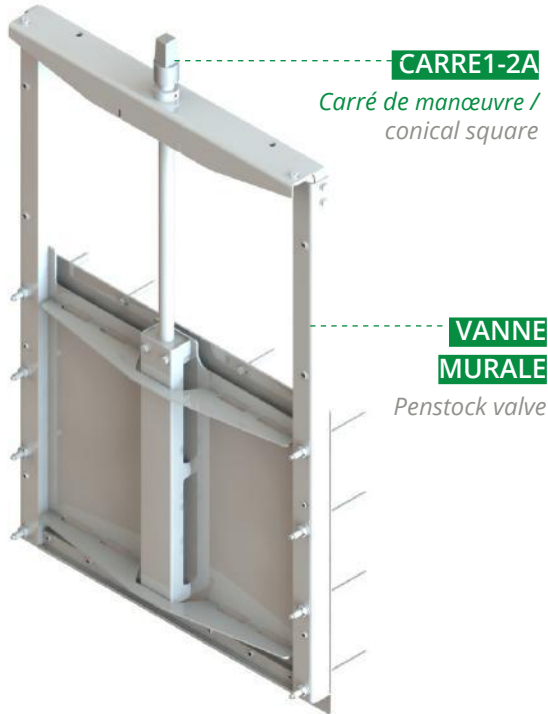

Commande à moteur électrique

Electric actuator mounted

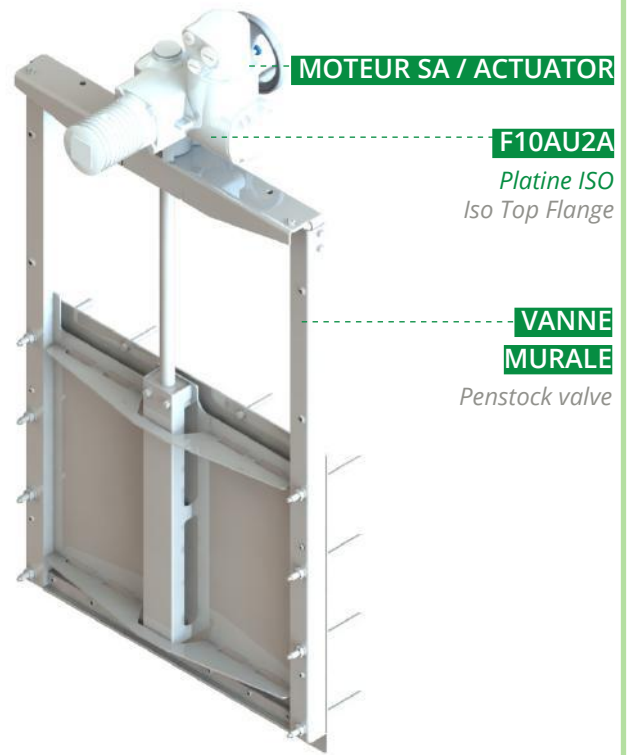

Commande à volant

Manual actuation

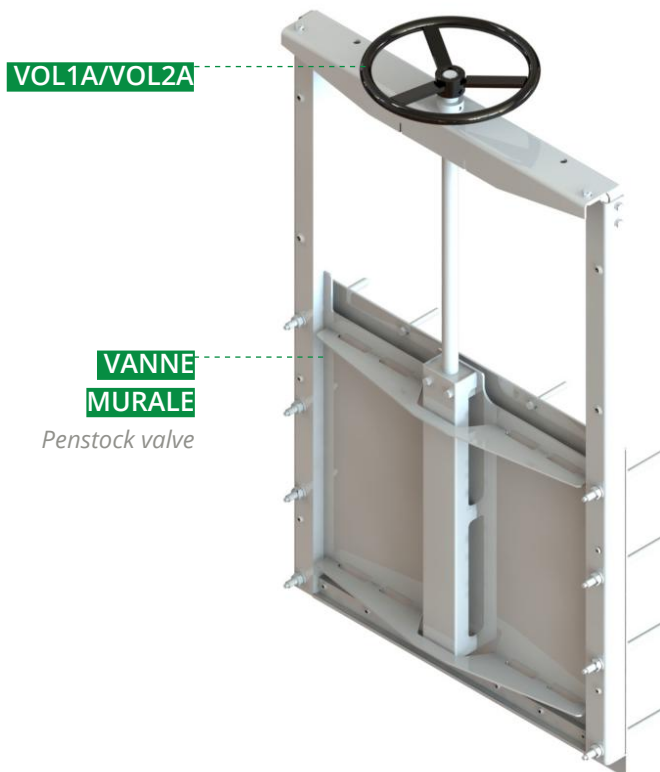



MONTAGE SUR COLONNETTE MURALE
PENSTOCK - FOR WALL MOUNTED PEDESTAL

Commande par carré de manœuvre à fleur

Square top on frame

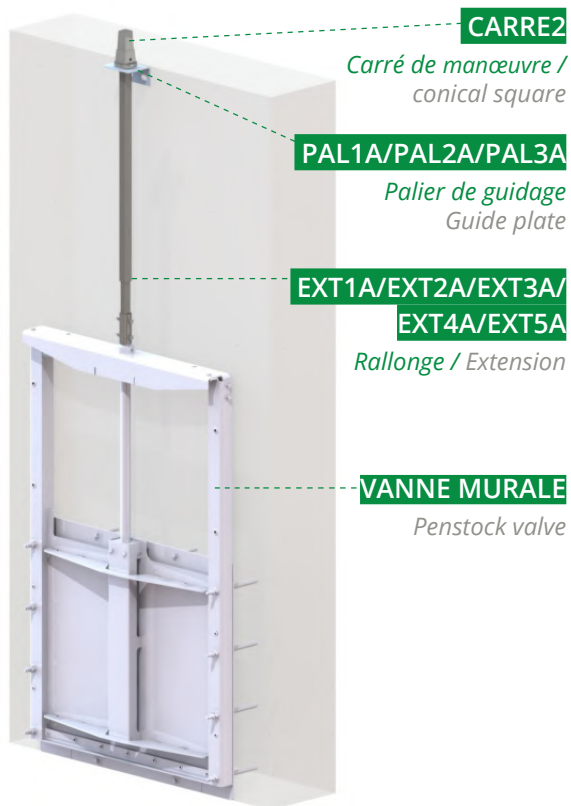

Commande à moteur électrique

Electric actuator mounted

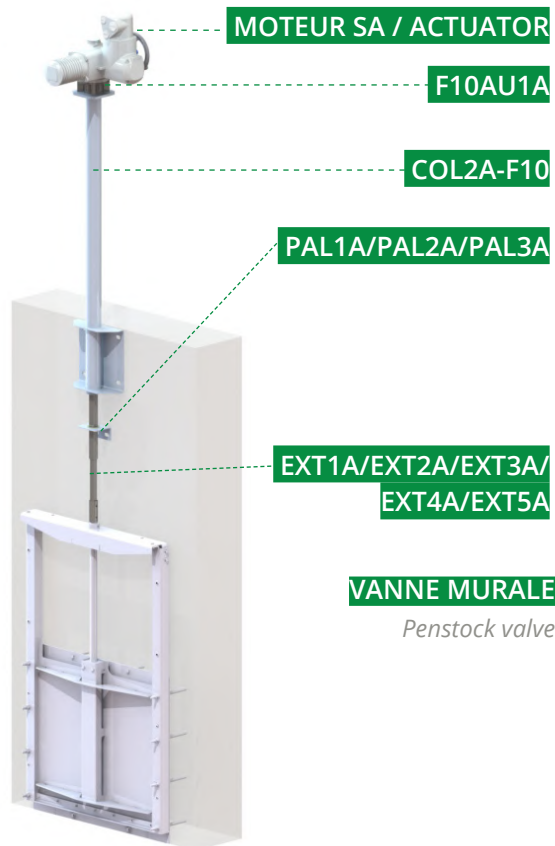

Commande à volant

Manual actuation

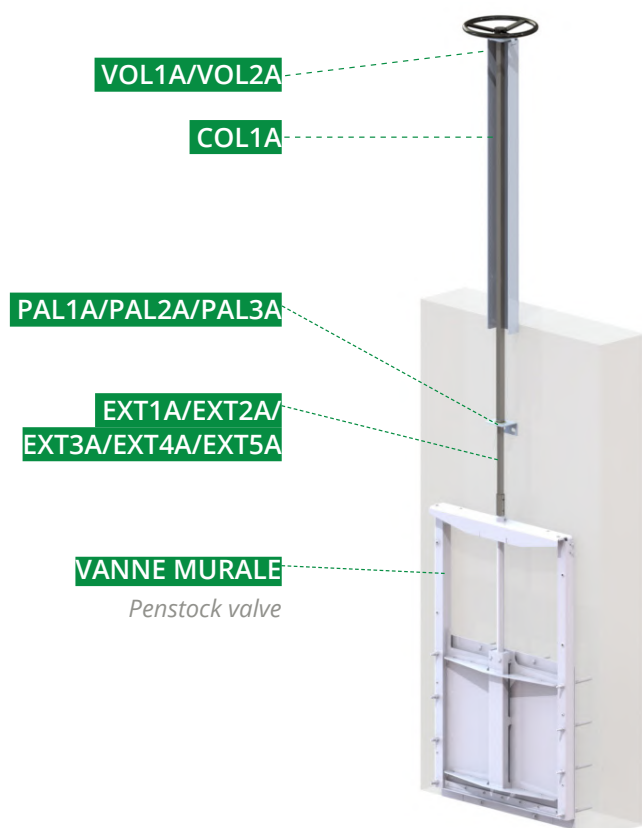



**MONTAGE SUR COLONNETTE DROITE
PENSTOCK - FOR STRAIGHT PEDESTAL**

Commande à moteur électrique sur colonnette

Electric actuator mounted

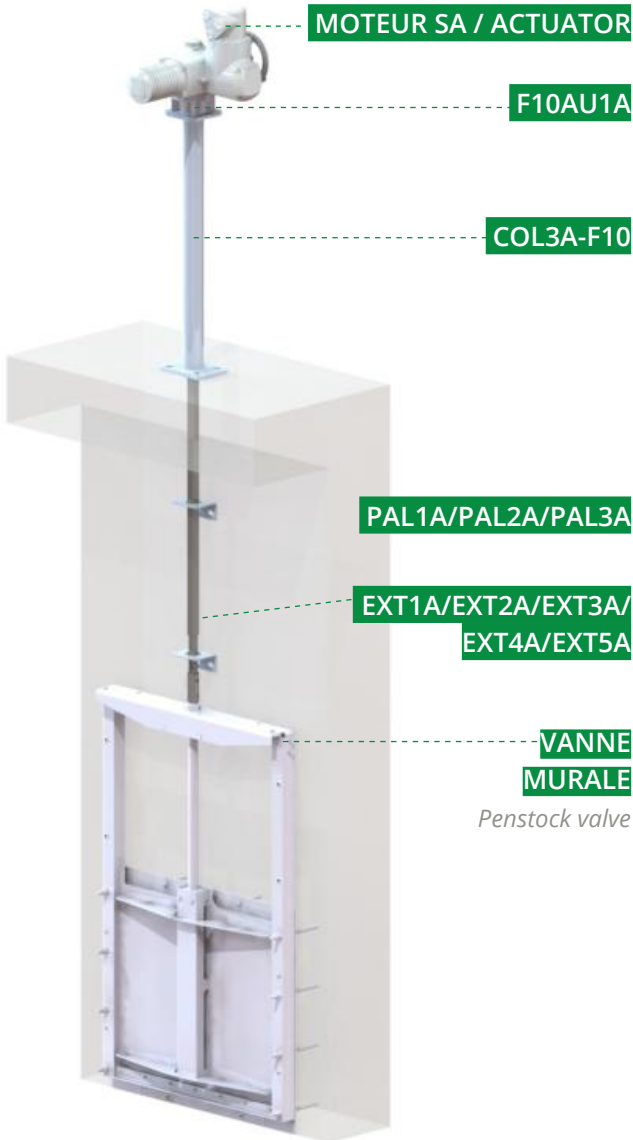

Commande à volant sur colonnette

Manual actuation

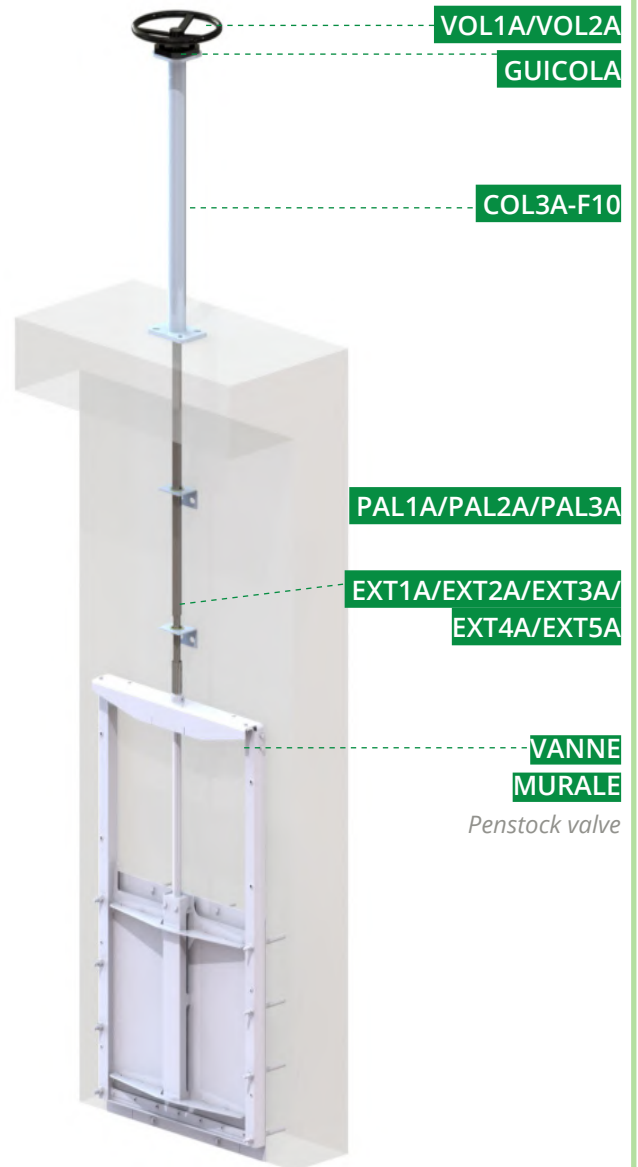



TRINGLERIES POUR VANNE MURALE LINKAGE FOR PENSTOCK

RALLONGE | EXTENSION

Rallonge télescopique se monte directement sur la tige de la vanne murale
Telescopic spindle extension



Matière : Inox 316L

Material: Stainless steel 316L



Ajouter la dimension H du passeport technique VGM6205-00 du bas de la vanne à la manoeuvre.

Add the dimension H from the VGM6205-00 technical sheet from the bottom of the vane to the actuator

Dimension (mm)	Ref.
800-1100	EXT1
1100-1750	EXT2
1750-3000	EXT3
3000-5500	EXT4
4000-8000	EXT5

PALIER DE GUIDAGE | GUIDE PLATE

Palier de guidage fixe pour rallonge télescopique
Guide plate for telescopic extension

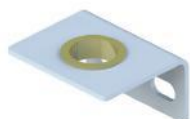

1



2



3



Matière : Inox 316L

Material: Stainless steel 316L

Dimension (mm)	Ref.
70	PAL1A
70-200	PAL2A
70-500	PAL3A



Mettre obligatoirement un palier tous les deux mètres + un autre avant le passage dans la colonnette.
Place one guide every two meters of the extension + one guide plate just before the pedestal floor

COLONNETTES | PEDESTAL

Colonnette pour vanne murale
Floor stand for penstock



1

2

3



1. COL1A : pour commande par volant et fixation murale
2. COL2A-F10 : pour commande motorisée (F10) et fixation murale
3. COL3A-F10 : pour commande motorisée (F10) et fixation au sol

Matière : Inox 304
Hauteur : 900mm

Pedestal wall mounted for handwheel
Pedestal wall mounted for Auma actuator (F10)
Pedestal floor mounted for Auma actuator (F10)

Material: Stainless steel 304
Height: 900mm

Ref.
COL1A
COL2A-F10
COL3A-F10



Type de manoeuvre | Actuation type



CARRÉ | SQUARE

Carré de manœuvre 30x30
Conical square 30x30



Matière : Inox 304

Material: Stainless steel 304

Ref.
CARRE1
CARRE2
Pour montage sur rallonge télescopique For telescopic stem extension

CLE DE FONTAINIER | HYDRANT KEY

Clé de fontainier
Hydrant key

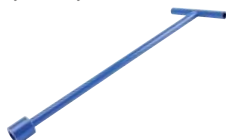

Matière : Acier
Carré : 30mm

Material: Steel
Square: 30mm

L	Ref.
1M	VOCLEWRENCH-1.0ML

Avec embout universel pour carré de manoeuvre
With universal end for operating square

PLAQUE DE GUIDAGE | SUPPORT PLATE

Guidage pour volant adaptable sur colonnette COL2-F10 / COL3-F10
Support plate for handwheel adaptable for COL2-F10 / COL3-F10



Matière : POM

Material: POM

Ref.
GUICOL

VOLANT | HANDWHEEL

Volant adaptable sur extension ou sur cadre
Handwheel suitable for extension or on frame



Matière : Acier revêtu Epoxy
Diamètre : 300mm

Material: Epoxy-coated carbon steel
Diameter: 300mm

DN	Ref.
200-500	VOL1
600-1000	VOL2

PLATINE POUR MOTEUR | MOTOR PLATE

Platine pour moteur Auma
Auma output drive

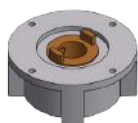

Matière : Acier
Platine : ISO5210
Pour montage sur extension «EXT»
F10AU1 : monté sur extension
F10AU2 : monté sur cadre
(livré avec goupille)

Material: Carbon steel
Top mounted flange: ISO5210
For telescopic extension mounting «EXT»
F10AU1: for extension
F10AU2: directly mounted on the penstock
(delivered with the pin)

Ref.
F10AU1
F10AU2

U04 - MOTEUR VG -VANNE MURALE | U04 AUMA ACTUATOR FOR PENSTOCK

Kit motorisation Auma TRI 400V/50Hz On/Off
3-phase Auma actuator 400V/50Hz On/Off



Moteur équipé de :
- 2 contacts fin de course
- 1 résistance de chauffe
- 2 limiteurs de couple
Commande manuelle de secours
Indicateur visuel de position
Protection IP68

Actuator equipped with:
- 2 limit switches
- 1 heat resistor
- 2 torque limiters
Emergency handwheel
Visual position indicator
IP68 protection

DN		Ref.
mm	inch	
200-700	8" - 28"	SA07.6-U04B1TOR90T
800-1000	32" - 40"	SA10.2-U04B1TOR90T

VANNE À GUILLOTINE
KNIFE GATE VALVE



NOTICE D'INSTALLATION ET D'UTILISATION USE AND INSTALLATION NOTE



VANNES À GUILLOTINE
KNIFE GATE VALVES

VANNES À GUILLOTINE KNIFE GATE VALVES

GÉNÉRALITÉS

Les vannes à guillotine sont toujours livrées avec le fouloir de presse-étoupe desserré. Avant toute utilisation, serrer progressivement le fouloir de presse-étoupe. (Voir Fig. 18)
Après mise sous pression du circuit, vérifier les fuites au niveau du presse étoupe et resserrer si nécessaire.
Respecter les positions de montage. (Voir Fig. 14)
Respecter le sens de montage de la vanne à guillotine. (Voir Fig. 16)

Pour un montage en bout de ligne, la vanne doit être montée «entre brides». (Voir Fig. 17)
S'assurer de la visibilité de l'indicateur.
Avant la mise en service, surtout en cas de stockage prolongé, graisser la vis de manœuvre. (Voir Fig.19)
Veillez au montage du tube de protection de la vis de manœuvre lors de la première installation.
La réserve de graisse de la vis de manœuvre est assurée dans le tube de protection, offrant un graissage régulier. Assurer régulièrement le maintien du niveau suffisant de graisse dans le tube de protection.
Lorsqu'un moteur est monté sur une vanne, veiller à graisser la noix du moteur et la tige de la vanne.

Vanne à guillotine type sous silo (Voir Fig. 20) :
A chaque démontage et remontage de la trappe de fond de corps, le joint de la trappe doit être changé.
Ne démonter la trappe que si le corps de la vanne n'est plus sous pression.

GENERALITIES

Knife gate valves are always delivered with the loosened packing gland. Before any use, tighten the gland gradually. (See Fig. 18)
After setting under pressure on line, check the leakage on the level of the packing and tighten if necessary.
Respect the recommended positions of assembly. (See Fig. 14)
Respect the knife gate valve assembling way. (See Fig. 16)

For bottom line assembling the valve must be installed between flanges. (See Fig. 17)
Be sure that the position indicator is visible.
Before the starting, especially in case of prolonged storage, lubricate the valve stem. (See Fig. 19)
Take care of the assembly of the protection tube of stem at the time of the first installation. The grease reserve of the stem is ensured in the protection tube, offering a regular greasing. Assure regularly the preservation of the sufficient level of grease in the tube of protection.
When assembling of an electric actuator on the valve, take care to lubricate the nut of the actuator and the stem of the valve.

Under silo special knife gate valve (See Fig. 20):
In every dismantling and reassembly of the trapdoor body, the trapdoor gasket must be changed.
Dismantle the trapdoor only if the body of the under silo special knife gate valve is not any more under pressure.

Types de montage Type of assembling

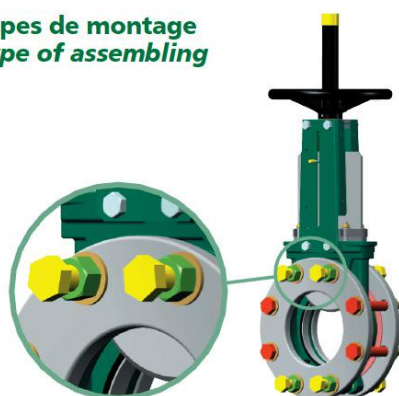

Montage type 1
Avec vis + écrous
et ensemble boulons.
Assembling type 1
With screws + nuts
and bolts set.

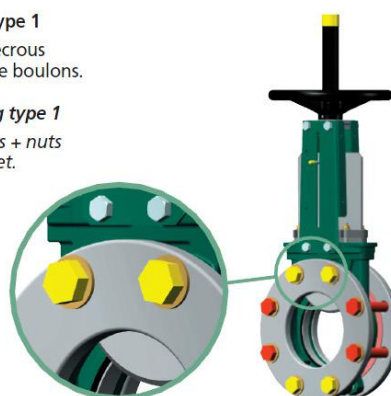

Montage type 2
Avec vis et ensemble
boulons.
Assembling type 2
With screws and
bolts set.



NOTICE D'INSTALLATION ET D'UTILISATION

USE AND INSTALLATION NOTE



VANNE À GUILLOTINE
KNIFE GATE VALVES

RACCORDEMENT ISO PN 10 POUR BRIDES TYPE 11B / ISO PN 10 CONNECTION FOR FLANGES TYPE 11B

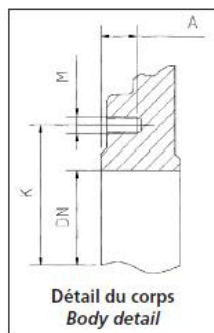
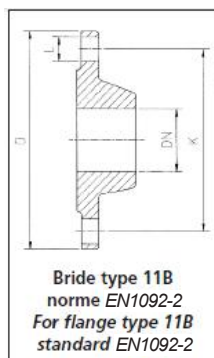

DN		Raccordement de la bride Flange connection			Equipement pour montage entre 2 brides Equipment for assembling between 2 flanges			
		Diamètre extérieur ø D External diameter	Diamètre de perçage des trous ø K Drilling circle	Trous Nombre x ø L Hole Number x ø L	Vis + écrou type 1 (jaune) Nombre x M-I Screw + nut type 1 (yellow) Number x M-Ig	Vis type 2 (jaune) Nombre x M-I Screw type 2 (yellow) Number x M-Ig	Profondeur de taraudage A Threading depth	Boulons type 1 et type 2 (rouge) Nombre x M-I Bolt type 1 and type 2 (red) Number x M-Ig
mm	inch	mm	mm			mm		
50	2"	165	125	4 x 18	8 x M 16-60	8 x M 16-25	8	-
65	2 1/2"	185	145	4 x 18	8 x M 16-60	8 x M 16-25	8	-
80	3"	200	160	8 x 18	8 x M 16-60	8 x M 16-30	9	4 x M 16-120
100	4"	220	180	8 x 18	8 x M 16-60	8 x M 16-30	9	4 x M 16-120
125	5"	250	210	8 x 18	8 x M 16-65	8 x M 16-30	9	4 x M 16-120
150	6"	285	240	8 x 22	8 x M 20-70	8 x M 20-35	10	4 x M 20-130
200	8"	340	295	8 x 22	8 x M 20-75	8 x M 20-35	12	4 x M 20-140
250	10"	395	350	12 x 22	16 x M 20-80	16 x M 20-40	12	4 x M 20-150
300	12"	445	400	12 x 22	16 x M 20-80	16 x M 20-40	12	4 x M 20-150
350	14"	505	460	16 x 22	20 x M 20-90	20 x M 20-45	19	6 x M 20-180
400	16"	565	515	16 x 26	20 x M 24-90	20 x M 24-50	20	6 x M 24-200
450	18"	615	565	20 x 26	28 x M 24-100	28 x M 24-55	24	6 x M 24-200
500	20"	670	620	20 x 26	28 x M 24-100	28 x M 24-55	24	6 x M 24-200
600	24"	780	725	20 x 30	28 x M 27-110	28 x M 27-50	24	6 x M 27-200
700	28"	895	840	24 x 30	32 x M 27	32 x M 27	-	8 x M 27-220
800	32"	1015	950	24 x 33	32 x M 30	32 x M 30	-	8 x M 30-220
900	36"	1115	1050	28 x 33	40 x M 30	40 x M 30	-	8 x M 30-220
1000	40"	1230	1160	28 x 36	40 x M 33	40 x M 33	-	8 x M 33-220
1200	48"	1455	1380	32 x 39	44 x M 36	44 x M 36	-	10 x M 36-240



DN 50-65



DN 80-200



DN 250-300



DN 350-400



DN 450-600



Les vis en jaune
Screws in yellow



Les boulons en rouge
Bolts in red



DN 700-800



DN 900-1000



DN 1200

COUPLE DE SERRAGE / TIGHTENING TORQUE

Acier normalisé classe 8-8 (suivant norme DIN ISO 898/1)

8-8 class standard steel (following standard DIN ISO 898/1)

DN (mm)	50	65	80	100	125	150	200	250	300	350	400	450	500	600	700	800	900	1000	1200
Filetage / Threading	M 16	M 16	M 16	M 16	M 16	M 20	M 20	M 20	M 20	M 20	M 24	M 24	M 24	M 27	M 27	M 30	M 30	M 33	M 36
Couple de serrage Tightening torque (Nm)	60	60	60	60	60	70	70	70	70	70	150	150	150	230	230	300	300	400	500
	190	190	190	190	190	370	370	370	370	370	650	650	650	940	940	1290	1290	1740	2250



NOTICE D'INSTALLATION ET D'UTILISATION USE AND INSTALLATION NOTE

VANNES À GUILLOTINE
KNIFE GATE VALVES



■ Position des vannes / Valves position

La vanne peut être montée dans toutes les positions. Cependant, nous préconisons des positions favorables.

The valve can be assembled in any position however, we recommend suitable position.

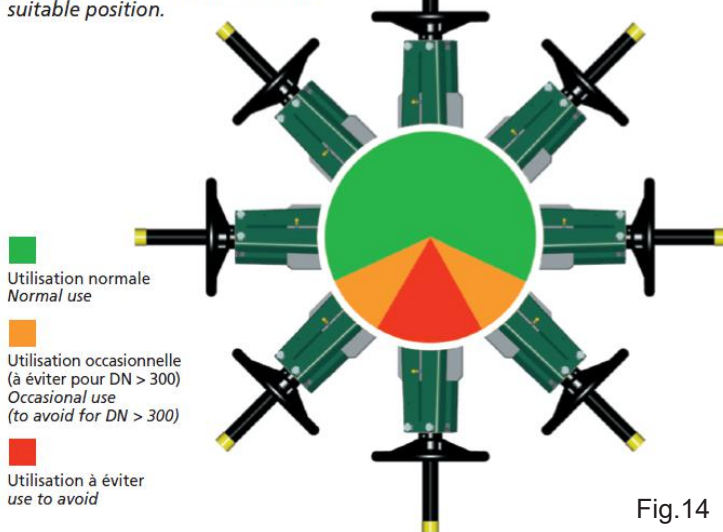

Fig.14

■ Maintenance des vannes Valves handling

Avant le montage, veuillez à manutentionner la robinetterie avec précaution.
Before assembling please handle the valve with care.



Fig.15

■ Sens de montage VG / VG knife gate valve assembling way

La vanne est unidirectionnelle, elle doit être installée de façon à ce que la pression du fluide plaque la pelle sur le joint. Le sens de montage inverse est fortement déconseillé et relève uniquement de la responsabilité de l'utilisateur. Veuillez donc à un montage conforme au sens de la flèche sur le corps (applications hydrauliques).

The valve is unidirectional it must be installed with the pressure which push the knife on the gasket. The flow direction is user responsibility. Please assemble the valve following the arrow on the body (hydraulic applications).

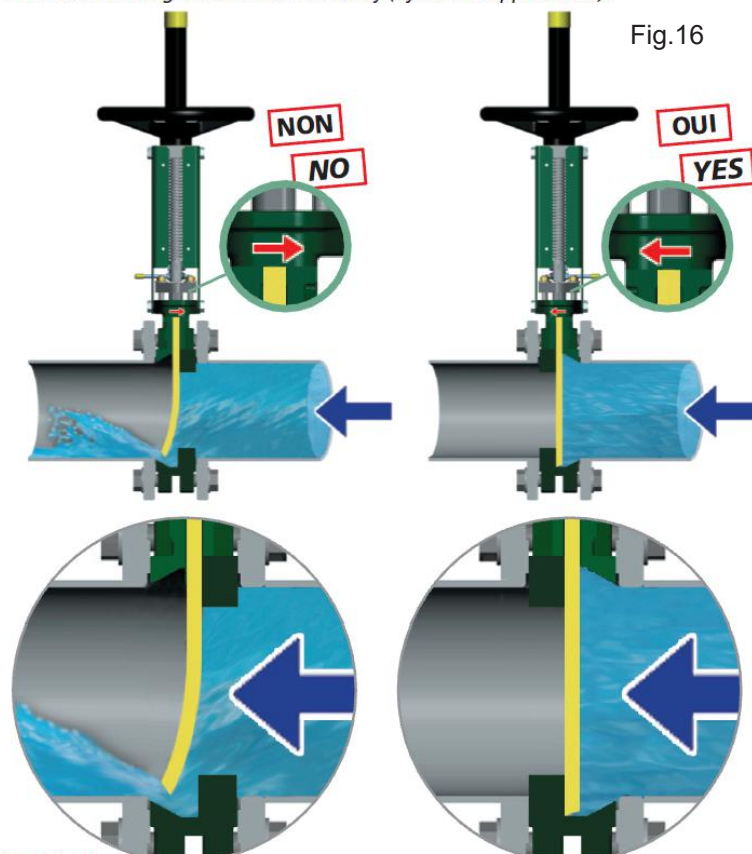

Fig.16

Attention !
Pour des applications de transport pneumatique ou de pulvérulents, nous consulter.
For applications of pneumatic transport or pulverized products, consult us.

■ Montage en bout de ligne Bottom line assembling

Pour un montage en bout de ligne, la vanne doit être montée «entre brides».
For bottom line assembling the valve must be installed between flanges.

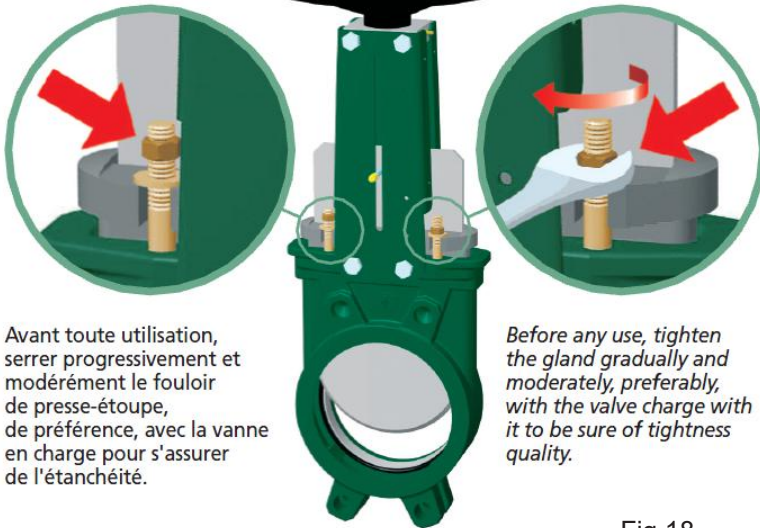

Fig.17



■ Serrage du fouloir de presse-étoupe / Tight the packing gland

Les vannes sont toujours livrées avec le fouloir de presse-étoupe desserré.
The valves are always delivered with the loosened packing gland.



Avant toute utilisation, serrer progressivement et modérément le fouloir de presse-étoupe, de préférence, avec la vanne en charge pour s'assurer de l'étanchéité.

Before any use, tighten the gland gradually and moderately, preferably, with the valve charge with it to be sure of tightness quality.

Fig.18

■ Montage sous silo : sens de montage VGS *Working under silo : VGS knife gate valve assembling way*

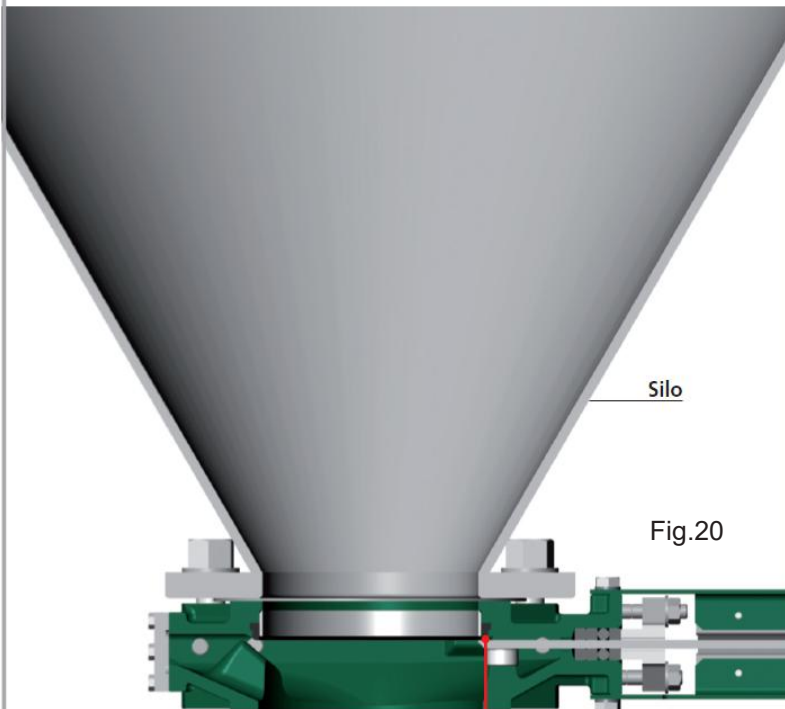

Pour une bonne évacuation, il est recommandé de monter la vanne avec le joint du même côté que le produit.
For good discharge it is recommended to assemble the valve with the gasket on the side of the product.

■ Graissage et tube de protection *Greasing and protection tube*

Veillez au montage du tube de protection de la vis de manœuvre lors de la première installation. La réserve de graisse de la vis de manœuvre est assurée dans le tube de protection, offrant un graissage régulier.
Take care of the assembly of the protection tube of stem at the time of the first installation. The grease reserve of the stem is ensured in the protection tube, offering a regular greasing.

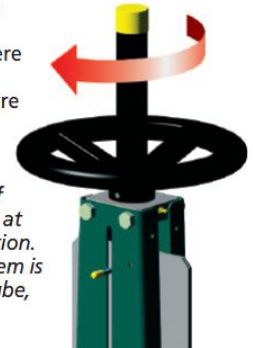

En cas de stockage prolongé ou de faible fréquence des manœuvres, graisser la vis de manœuvre régulièrement.
In the event of prolonged storage or of weak frequency of operation, lubricate the valve stem regularly.



Fig.19

■ Supportage des vannes / Valves support

Les vannes manuelles au diamètre important, les vannes munies d'actionneurs lourds tels que vérins, moteurs électriques..., doivent être supportées à l'aide de la plaquette de supportage fournie, lorsqu'elles sont montées en position horizontale ou inclinée.
The manual valves in large diameter, valves equipped with heavy actuators such as actuators, electric motors..., should be supported by means of the retaining plate supplied, when they are mounted horizontally or inclined.

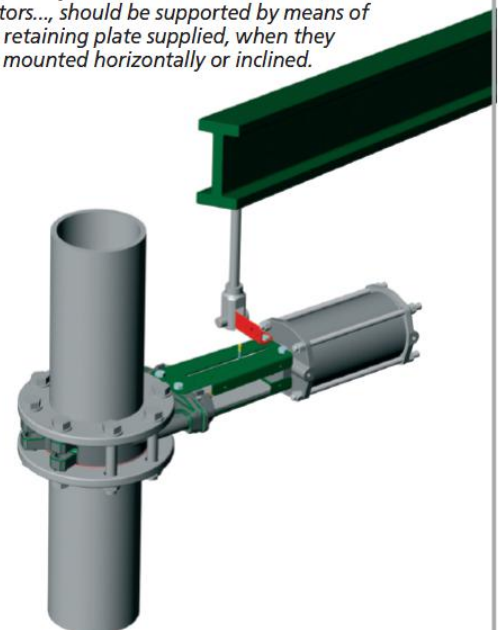

Fig.21



NOTICE D'INSTALLATION ET D'UTILISATION USE AND INSTALLATION NOTE



REPLACEMENT DES JOINTS / PACKING AND SEAT REPLACEMENT

Les pièces généralement remplacées sont la garniture de presse-étoupe, le siège de la vanne, les joints du vérin (en cas de commande pneumatique) et la pelle. Leur durée de vie dépend largement des cycles d'utilisation en pression, température, quantité de manœuvres, agressivité chimique, etc.

Il est recommandé de contrôler l'alignement «pelle / organe de manœuvre» dans le corps de la vanne avant de resserrer complètement les plaques supports.

The parts that need replacement are: packing, valve seat, gasket (for pneumatic actuator) and gate. Their life cycles depend largely on the use of pressure, temperature, amount of maneuvers, aggressive chemicals, etc.

It is necessary to control the alignment of the gate in body with the operating organ before to screw absolutely plates support.

Remplacement de la garniture de presse-étoupe :

- Dépressuriser le circuit et mettre la vanne en position fermée.
- Désaccoupler la pelle (1) et la tige.
- Desserrer les écrous (2) du fouloir et enlever celui-ci (8).
- Oter les anciennes tresses (5) et le joint torique (6) puis nettoyer le logement (7).
- Placer les nouvelles tresses (5) et le joint torique (6) en alternant les jointures (voir figure A).
- Replacer le fouloir (8) et les écrous (2) de celui-ci.
- Refixer la tige sur la pelle (1).
- Remettre le circuit en charge tout en resserrant les écrous du fouloir (2) jusqu'à obtenir l'étanchéité.

Packing replacement:

- Check your pipe is without pressure and close your valve.
- Disconnect the gate (1) and stem.
- Unscrew the nuts of the packing gland (2) and take it off (8).
- Take out the old braids and O-ring (5) (6) and clean the inside (7).
- Put the new braids and O-ring alternating the joints (see fig. A).
- Put the packing gland (8) and its nuts (2).
- Fix the stem on the gate (1).
- Put the pipe under pressure while tightening the nuts of the packing gland (2) until you get tightness.

Remplacement du joint de pelle (sur vannes étanches) :

- Déposer la vanne.
- Retirer l'organe de manœuvre.
- Enlever la pelle (1).
- Oter la bague support en inox (4).
- Oter le joint usagé (3) et nettoyer son emplacement.
- Placer le nouveau joint moulé (3) dans son logement.
- Monter la bague support (4) en la martelant sur tout le diamètre pour la placer dans son logement (voir figure B).
- Replacer la pelle (1) sans endommager le siège.
- Refixer l'organe de manœuvre et faites plusieurs manœuvres d'ouverture et de fermeture avant de replacer la vanne sur l'installation.
- Avant de resserrer complètement les plaques supports contrôler l'alignement de la pelle dans le corps avec l'organe de manœuvre (surtout en pneumatique).

Replacement of the valve seat (on tight valves):

- Take the valve out.
- Take the operator out.
- Take the gate of (1).
- Take the stainless steel ring off (4).
- Take the used gasket (3) and clean its place.
- Put the new shaped gasket (3) in the place.
- Assemble the support ring (4) hammering it on all diameter to take its place (see fig. B).
- Put the gate back without damaging the seat (1).
- Fix the operator and make few openings and closings before replacing the valve on the pipe.
- Before to screw absolutely plates support control the alignment of the gate in body with the operating organ (especially pneumatic actuator).

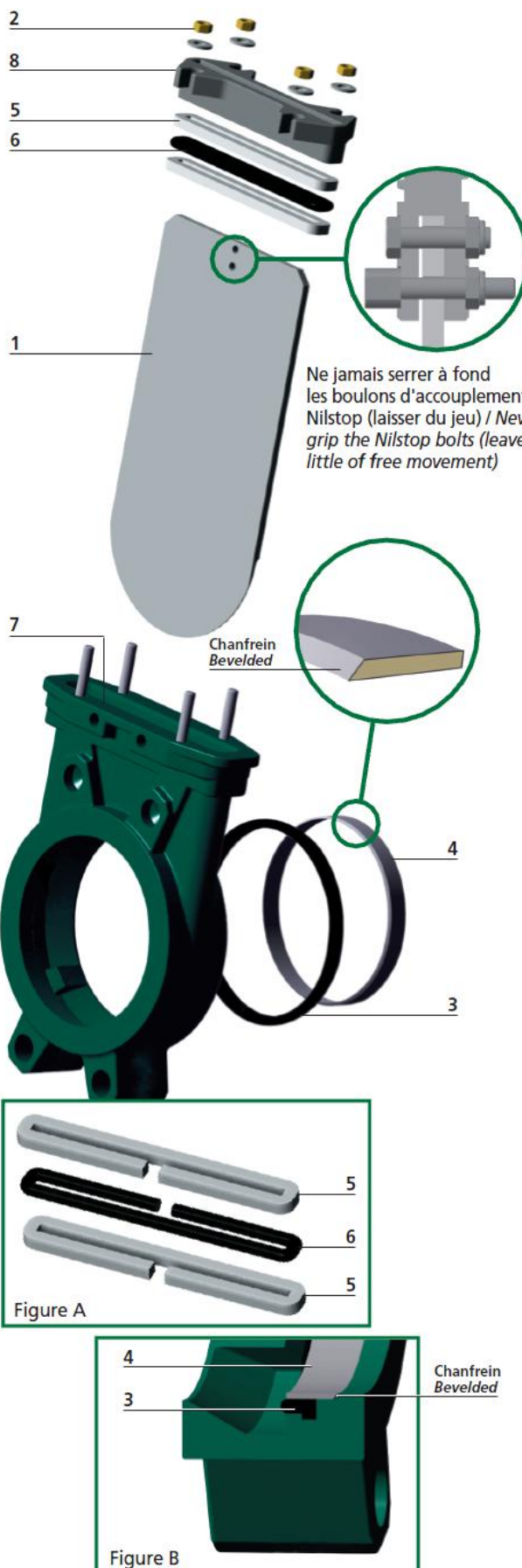

Ne jamais serrer à fond les boulons d'accouplement Nilstop (laisser du jeu) / Never grip the Nilstop bolts (leave a little of free movement)

Chanfrein Bevelled

Chanfrein Bevelled



NOTICE D'INSTALLATION ET D'UTILISATION

USE AND INSTALLATION NOTE



VANNES À GUILLOTINE
KNIFE GATE VALVES

PIÈCES DÉTACHÉES DE VÉRIN PNEUMATIQUE DOUBLE EFFET DOUBLE-ACTING PNEUMATIC ACTUATOR SPARE PARTS

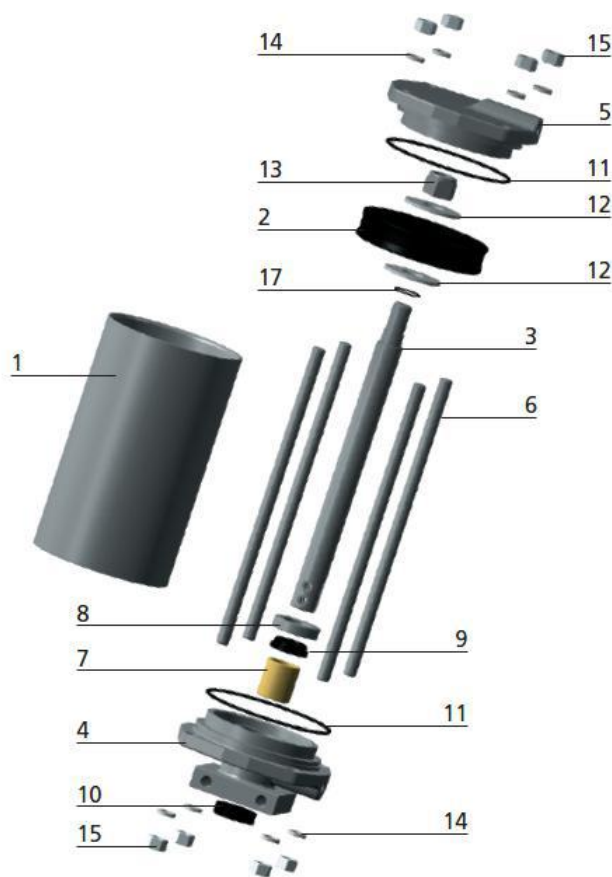

Vérin pneumatique
double effet
Double acting pneumatic
actuator

- | | | |
|-------------------------------------|--------------------------------------|---------------------------------------|
| 1. Tube | 7. Bague de guidage / Guiding ring | 13. Ecrou frein / Self-locking nut |
| 2. Piston | 8. Ecrou de blocage / Locking nut | 14. Rondelle / Washer |
| 3. Tige / Stem | 9. Joint d'étanchéité / Gasket | 15. Ecrou / Nut |
| 4. Flasque inférieur / Lower flange | 10. Joint cache-poussière / Dust cap | 16. Ressort de rappel / Return spring |
| 5. Flasque supérieur / Top flange | 11. Joint torique / O ring | 17. Joint / Gasket |
| 6. Tirants / Rods | 12. Rondelle / Washer | |

Vérin pneumatique double effet*
Double acting pneumatic
actuator*



* Fonctionnement avec air lubrifié (Pmaxi = 7 bar / Ps = 6 bar / Pmini = 5 bar)
Working with lubricated air (maxi pressure 7 bar, working pressure 6 bar,
minimum pressure 5 bar).

Vérin pneumatique double effet*
pour vanne DN > 300
Double acting pneumatic actuator*
for valve DN > 300

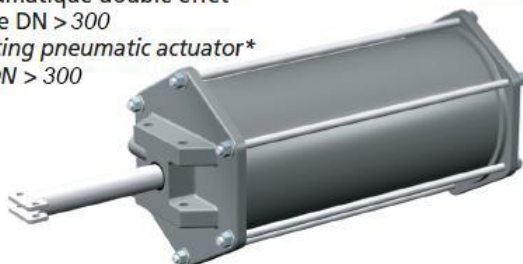



INSTRUCTIONS SPÉCIFIQUES POUR LA MISE EN PLACE ET L'UTILISATION DE LA COMMANDE MANUELLE DE SECOURS DU VÉRIN PNEUMATIQUE DOUBLE EFFET

- 1 – Couper l'alimentation pneumatique du vérin (débrancher l'électrodistributeur).
- 2 – Déposer le capot de protection se situant du côté de l'accroche de la chaîne. (Voir Fig.22)
- 3 – Dévisser le maillon rapide de la chaîne pour libérer le volant. (Voir Fig.23)
- 4 – Faire descendre la tige en actionnant le volant dans le sens «CLOSE» (Voir Fig. 24) jusqu'à ce que l'empreinte mâle de la tige du vérin coïncide dans l'empreinte femelle de la tige du volant. (Voir Fig. 25)
Attention : Il peut être nécessaire de maintenir la tige pour bloquer sa rotation et permettre sa translation. (Utiliser des gants de protection)

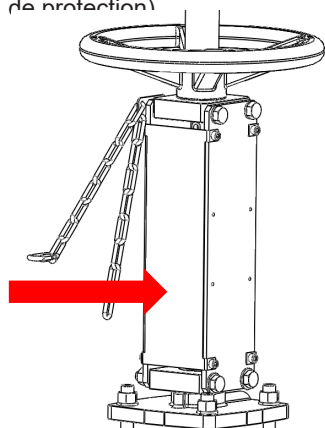

Fig.22

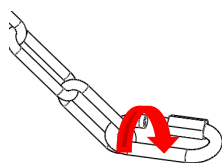

Fig.23

SPECIAL INSTRUCTIONS FOR THE INSTALLATION AND THE USE OF MANUAL EMERGENCY OPERATING OF THE DOUBLE-ACTING PNEUMATIC ACTUATOR

- 1 - Close pneumatic supply of pneumatic actuator.
- 2 - Disassemble the safety protection being situated near the chain fixation. (See Fig. 22)
- 3 - Discrew the chain fast link to release the handwheel. (See Fig. 23)
- 4 - Make go down the stem by operating the handwheel in the "CLOSE" direction (See Fig. 24) until the male imprint of the pneumatic actuator stem coincides in the female imprint of the handwheel stem. (See Fig. 25)
Attention: It can be necessary to maintain the stem to block his rotation and allow his translation. (Use oven gloves)

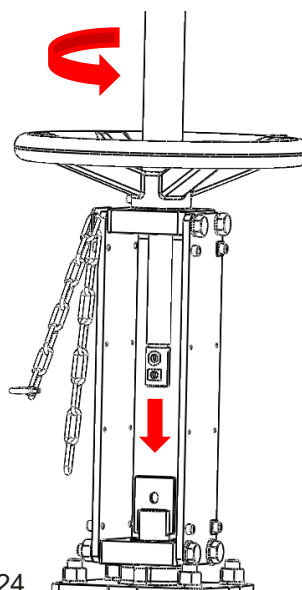

Fig.24

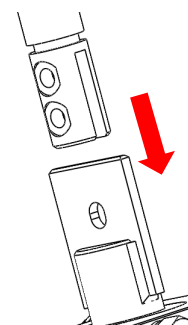

Fig.25

- 5 – Goupiller les deux tiges ensemble à l'aide de l'axe fixé sur la chaîne (Voir Fig. 27), après avoir préalablement retiré la goupille épingle (Voir Fig. 26). Une fois l'axe inséré, insérer la goupille épingle sur celui-ci. (Voir Fig. 28)

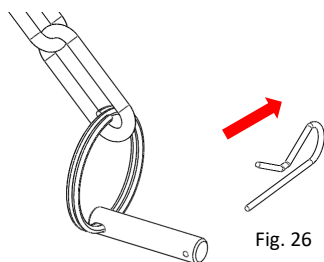

Fig. 26

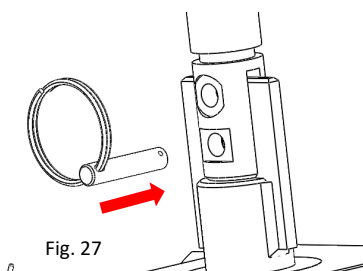

Fig. 27

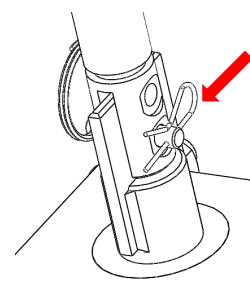

Fig. 28

- 6 – La commande manuelle de secours est prête à être utilisée pour ouvrir ou fermer la vanne.

- 6 - The manual emergency operating is ready to be to use to open or close the valve.



INSTRUCTIONS SPÉCIFIQUES POUR DÉSACCOUPLER LA COMMANDE MANUELLE DE SECOURS DU VÉRIN PNEUMATIQUE DOUBLE EFFET

1 - Désolidariser les deux tiges ensemble en ôtant l'axe fixé sur la chaîne (Voir Fig. 30), après avoir préalablement retiré la goupille épingle (Voir Fig. 29). Une fois l'axe retiré, insérer la goupille épingle sur celui-ci. (Voir Fig. 31)

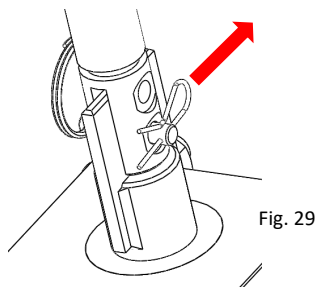

Fig. 29

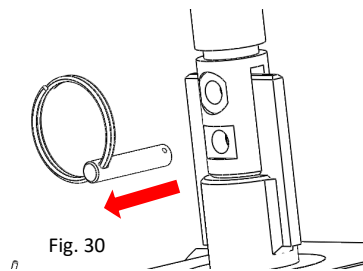

Fig. 30

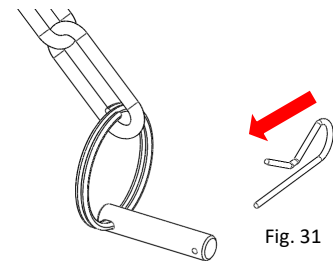

Fig. 31

SPECIAL INSTRUCTIONS TO UNCOUPLE THE MANUAL EMERGENCY OPERATING OF THE DOUBLE-ACTING PNEUMATIC ACTUATOR

1 - Separate the two stems by removing the axis fixed to the chain (See Fig. 30), having before removed the safety pin (See Fig. 29). Once out-of-the-way axis, insert the safety pin to this one. (See Fig. 31)

2 - Faire remonter la tige en actionnant le volant dans le sens «OPEN» jusqu'à ce que la commande manuelle de secours bute dans sa position la plus haute. (Voir Fig. 32)

Attention : Il peut être nécessaire de maintenir la tige pour bloquer sa rotation et permettre sa translation. (Utiliser des gants de protection)

3 - Verrouiller le volant à l'aide de la chaîne et du maillon rapide. (Voir Fig. 33)

4 - Assembler les capots de protections de la partie commande manuelle de secours.

5 - Alimenter en air comprimé le vérin pneumatique double effet.

6 - La commande par vérin pneumatique est prête à être utilisée pour ouvrir ou fermer la vanne.

2 - Make go up the stem by operating the handwheel in the "OPEN" direction until the manual emergency operating to be in its high position. (See Fig. 32)

Attention: It can be necessary to maintain the stem to block his rotation and allow his translation. (Use oven gloves)

3 - Lock the handwheel by means of the chain and of the fast link. (See Fig. 33)

4 - Assemble the safety protections of manual emergency operating. (See Fig. 34)

5 - Fed with compressed air the double-acting pneumatic actuator.

6 - The operating by pneumatic actuator is ready to be to use to open or close the valve.

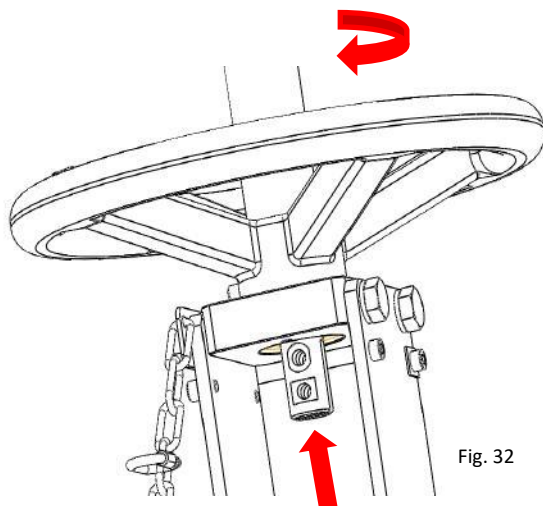

Fig. 32

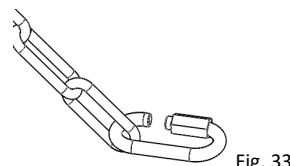

Fig. 33

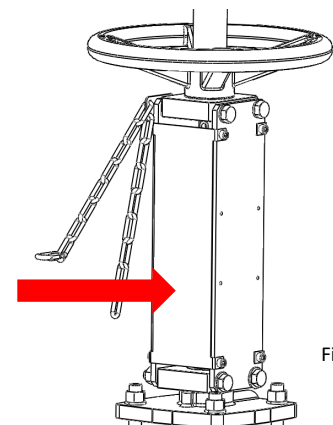

Fig. 34



CLAPET | FILTRE CHECK VALVE | STRAINER

CLAPETS AXIAUX AXIAL CHECK VALVES

162 > 168

CLAPETS À BOULE BALL CHECK VALVES

169 > 170

CLAPETS À BATTANT SWING CHECK VALVES

171 > 177

CLAPETS À SOUPAPE LIFT CHECK VALVES

178

NEW

CLAPETS D'EXTREMITÉ TERMINAL CHECK VALVES

179

CLAPETS À PAPILLON TILTING CHECK VALVES

180

DISCONNECTEURS BACKFLOW PREVENTERS

181

CONSEILS TECHNIQUES TECHNICAL NOTES

182 > 184

FILTRES STRAINERS

185 > 191

NEW

FILTRES À PANIER BASKET STRAINERS

192

BOÎTES À BOUE FLANGED H-STRAINERS

193

CLAPET DE NON RETOUR À FERMETURE RAPIDE

QUICK-CLOSING NON-RETURN CHECK VALVE

NEW

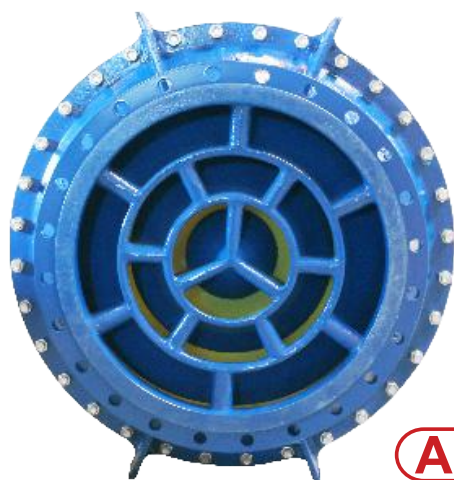

Clapet de haute qualité à faible inertie pour assurer la sécurité de vos réseaux d'eau.



High quality, low inertia check valve to secure your water networks.

ACS

- ✓ Minimise les coups de bélier - **Excellente réponse dynamique**
Prevents water hammer - Excellent dynamic solution
- ✓ Fonctionne en toutes positions d'installation : ressort inox de rappel
Used in all installation positions: Stainless steel counter spring
- ✓ Excellent comportement hydraulique : faibles pertes de charge
Optimum hydraulic operation: low pressure loss (optimal flow)
- ✓ Manoeuvre silencieuse - Absence de vibration
Operates silently - No vibration
- ✓ Étanchéité 100% en position fermée
100% sealing in closed position
- ✓ Absence de maintenance de part sa conception
No maintenance due to its design (no seat gasket, no obturator wear)
- ✓ Robuste et résistant : corps et anneau en fonte ductile GGG40
Ressort Inox 302 | *Robust and resistant: body and ring in ductile iron GGG40 - Stainless steel spring 302*
- ✓ Revêtement époxy ACS épaisseur minimum 250microns
Epoxy coating minimum thickness 250microns
- ✓ Certifié ACS pour eau potable
ACS certification for potable water



Conception Innovante

- ✓ Obturateur léger et de faible inertie (course limitée à 1/10 du diamètre nominal).
- ✓ Obturateur en polyuréthane qui absorbe les chocs.
- ✓ Absence de pièce mécanique.
- ✓ Profil hydraulique permettant un écoulement optimal.
- ✓ Gamme unique : raccordement entre-brides PN10/16/25/40/ASA150/ASA300.

Innovative design

- ✓ Light-weight obturator with low inertia (short operation travel limited to 1/10th of nominal diameter).
- ✓ Obturator made of polyurethane to absorb the shocks.
- ✓ No mechanical parts.
- ✓ Hydraulic design allowing optimal flow.
- ✓ Unique range: wafer type for PN10/16/25/40/ASA150/300 flanges.

CA4460

Clapet de non retour à fermeture rapide entre brides PN10-16-25-40-ASA150-ASA300
Quick-closing non-return valve PN10-16-20-25-40-ASA150-ASA300



Corps : Fonte ductile EN-GJS-400-15 (GGG40)
Anneau : Fonte ductile EN-GJS-400-15 (GGG40)
Obturateur : Polyuréthane
Ressort : Inox 302
Étanchéité : SBR
Raccordement : Entre brides PN10, PN16, PN25, PN40, ASA150, ASA300
Pression de service max : 40 bar
Température de service max : +60°C

Body: Ductile iron EN-GJS-400-15 (GGG40)
Ring: Ductile iron EN-GJS-400-15 (GGG40)
Obturator: Polyurethane
Spring: Stainless steel 302
Seal: SBR
Connection: Between flanges PN10, PN16, PN25, PN40, ASA150, ASA300
Maximum working pressure: 40 bar
Maximum working temperature: +60°C

DN	L (mm)		Kg	Ref.
	mm	inch		
50	2"	50	1	CA4460-0050
65/80	3"	80	2	CA4460-0080
100	4"	100	6	CA4460-0100
125	5"	125	11	CA4460-0125
150	6"	150	17	CA4460-0150
200	8"	127	22	CA4460-0200
250	10"	146	35	CA4460-0250
300	12"	181	50	CA4460-0300
350	14"	222	80	CA4460-0350
400	16"	232	100	CA4460-0400
450	18"	260	135	CA4460-0450
500	20"	292	180	CA4460-0500

ACS



Gamme unique et complète
PN10/16/25/40/ASA150/ASA300
One single and complete range
PN10/16/25/40/ASA150/ASA300



CA4200 | CA4240 | CA4250 | CA4260

Clapet de non retour à fermeture rapide à brides grand DN ACS

Quick-closing non-return valve, large sizes ACS



Corps : Fonte ductile EN-GJS-400-15 (GGG40)
 Anneau : Fonte ductile EN-GJS-400-15 (GGG40)
 Obturateur : Elastomère de polyuréthane
 Ressort de compression : Inox 302
 Étanchéité : SBR
 Raccordement : À brides PN10; PN16; PN25; PN40
 Pression de service : 10/16/20/25/40 bar
 Température de service max : +60°C
 Prix sur demande
 ASA 150 / 300 sur demande

Body: Ductile iron EN-GJS-400-15 (GGG40)
 Ring: Ductile Iron EN-GJS-400-15 (GGG40)
 Obturator: Polyurethane
 Spring: Stainless steel 302
 Seal: SBR
 Connection: Flanged PN10; PN16; PN25; PN40
 Working pressure: 10/16/20/25/40 bar
 Maximum working temperature: +60°C
 Prices on request
 ASA 150/300 on request



DN		L (mm)	Kg*	PN10	PN16	PN25	PN40
mm	inch			Ref.	Ref.	Ref.	Ref.
600	24"	435	500	CA4200-0600	CA4240-0600	CA4250-0600	CA4260-0600
700	28"	500	800	CA4200-0700	CA4240-0700	CA4250-0700	CA4260-0700
800	32"	515	1000	CA4200-0800	CA4240-0800	CA4250-0800	CA4260-0800
900	36"	710	1700	CA4200-0900	CA4240-0900	CA4250-0900	CA4260-0900
1000	40"	730	1900	CA4200-1000	CA4240-1000	CA4250-1000	CA4260-1000
1200	48"	900	3400	CA4200-1200	CA4240-1200	CA4250-1200	CA4260-1200

*susceptible de changement, DN supérieurs sur demande / change possible, other DN on request

Clapet de non retour à fermeture rapide à brides grand DN NON ACS

Quick-closing non-return valve, large sizes NON ACS

DN		L (mm)	Kg*	PN10	PN16	PN25	PN40
mm	inch			Ref.	Ref.	Ref.	Ref.
600	24"	435	500	CA4200A-0600	CA4240A-0600	CA4250A-0600	CA4260A-0600
700	28"	500	800	CA4200A-0700	CA4240A-0700	CA4250A-0700	CA4260A-0700
800	32"	515	1000	CA4200A-0800	CA4240A-0800	CA4250A-0800	CA4260A-0800
900	36"	710	1700	CA4200A-0900	CA4240A-0900	CA4250A-0900	CA4260A-0900
1000	40"	730	1900	CA4200A-1000	CA4240A-1000	CA4250A-1000	CA4260A-1000
1200	48"	900	3400	CA4200A-1200	CA4240A-1200	CA4250A-1200	CA4260A-1200

*susceptible de changement, DN supérieurs sur demande / change possible, other DN on request

ASSUREZ LA SÉCURITÉ DE VOS RÉSEAUX D'EAU !
 ENSURE THE SECURITY OF YOUR WATER NETWORKS!

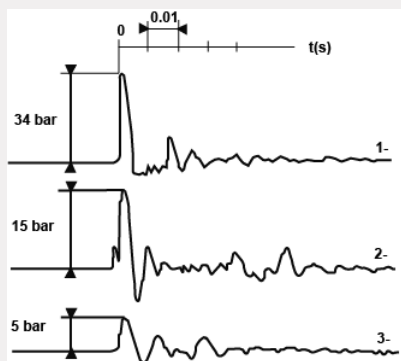

Excellente réponse dynamique
 Excellent dynamic response

Exemple d'enregistrements de la surpression durant la fermeture de plusieurs types de clapets de non-retour, dans les mêmes conditions de fonctionnement.

Sample of overpressure records taken during water hammer tests of various types of check valves operating under identical conditions.

- 1 - Clapet à simple battant (wafer swing check valve)
- 2 - Clapet double battant (dual plate check valve)
- 3 - Clapet à fermeture rapide TECOFI CA4460, CA4240, CA4250, CA4260 (TECOFI quick-closing check valve)

CLAPET/FILTRE
CHECK VALVE/STRAINER



CLAPETS AXIAUX
AXIAL TYPE CHECK VALVES

CA1103

Clapet axial laiton femelle BSP "toutes positions"

All position female BSP check valve



Corps : Laiton CW617N
Clapet : ABS
Ressort : Inox
Étanchéité : Nitrile
Raccordement : Femelle / Femelle BSP
Pression de service : 16 bar
Température de service : -20°C/+100°C

Body: Brass CW617N
Disc: ABS
Spring: Stainless steel
Seal: Nitrile
Connection: Female / Female BSP
Working pressure: 16 bar
Working temperature: -20°C/+100°C

JUSQU'À ÉPUISEMENT DES STOCKS
WHILE STOCKS LAST

DN		L (mm)	Kg	Ref.
mm	inch			
15	1/2"	45	0,12	CA1103-0015
20	3/4"	48	0,18	CA1103-0020
25	1"	54,5	0,24	CA1103-0025
32	1"1/4	58	0,33	CA1103-0032
40	1"1/2	65,5	0,50	CA1103-0040
50	2"	71,5	0,70	CA1103-0050

CC1142

Clapet crépine femelle BSP "toutes positions"

Female BSP all position foot type check valve



Corps : Laiton
Clapet : Nylon
Étanchéité : Nitrile
Crépine : Inox 304
Raccordement : Femelle / Femelle BSP
Pression de service : 8 à 16 bar
Température de service : 0°C/+65°C

Body: Brass
Disc: Nylon
Seal: Nitrile
Strainer: Stainless steel 304
Connection: Female / Female BSP
Working pressure: 8 to 16 bar
Working temperature: 0°C/+65°C

JUSQU'À ÉPUISEMENT DES STOCKS
WHILE STOCKS LAST

DN		L (mm)	Kg	Ref.
mm	inch			
15	1/2"	34,5	0,10	CC1142-0015
20	3/4"	42	0,12	CC1142-0020
25	1"	47,5	0,16	CC1142-0025
32	1"1/4	59,5	0,22	CC1142-0032
40	1"1/2	71	0,33	CC1142-0040
50	2"	86,5	0,5	CC1142-0050
65	2"1/2	102	1,02	CC1142-0065
80	3"	125	1,35	CC1142-0080
100	4"	155	1,85	CC1142-0100

CA1142

Clapet axial laiton femelle BSP "toutes positions"

Female BSP all position axial type check valve



Corps : 2 pièces Laiton CW617N
Obtuteur : Nylon
Ressort : Acier Inoxydable
Étanchéité : Nitrile
Raccordement : Femelle / Femelle BSP
Pression de service : 16 bar
Température de service : -20°C/+100°C

Body: 2-piece Brass CW617N
Disc: Nylon
Spring: Stainless steel
Seal: Nitrile
Connection: Female / Female BSP
Working pressure: 16 bar
Working temperature: -20°C/+100°C

NEW

(ACS) En cours / In progress

DN		L (mm)	Kg	Ref.
mm	inch			
15	1/2"	46,5	0,11	CA1142-0015
20	3/4"	50	0,16	CA1142-0020
25	1"	57	0,21	CA1142-0025
32	1"1/4	60,5	0,33	CA1142-0032
40	1"1/2	71	0,52	CA1142-0040
50	2"	74,5	0,74	CA1142-0050
65	2"1/2	100	1,14	CA1142-0065
80	3"	109,5	1,71	CA1142-0080
100	4"	114	3,10	CA1142-0100

CC1142A

Clapet crépine femelle BSP "toutes positions"

Female BSP all position foot type check valve



Corps : Laiton
Clapet : Nylon
Étanchéité : Nitrile
Crépine : Inox 304
Raccordement : Femelle / Femelle BSP
Pression de service max : 16 bar
Température de service : -20°C/+100°C

Body: Brass
Disc: Nylon
Seal: Nitrile
Strainer: Stainless steel 304
Connection: Female / Female BSP
Maximum working pressure: 16 bar
Working temperature: -20°C/+100°C

NEW

DN		L (mm)	Kg	Ref.
mm	inch			
15	1/2"	67,3	0,075	CC1142A-0015
20	3/4"	78,5	0,11	CC1142A-0020
25	1"	90	0,14	CC1142A-0025
32	1"1/4	102	0,22	CC1142A-0032
40	1"1/2	117,5	0,36	CC1142A-0040
50	2"	134,5	0,52	CC1142A-0050

CR3201 | CR6146

Crépines Inox pour clapet

Stainless steel screens for check valves



Matière CR3201 : Inox 316
Matière CR6146 : Inox 304 + bague fileté en Nylon
Raccordement : Mâle BSP

Material CR3201: Stainless steel 316
Material CR6146: Stainless steel 304 + Nylon male threaded
Connection: BSP male

NEW

(ACS) En cours / In progress



DN		Ref.
mm	inch	
10	3/8"	CR3201-0010
15	1/2"	CR3201-0015 CR6146-0015
20	3/4"	CR3201-0020 CR6146-0020
25	1"	CR3201-0025 CR6146-0025
32	1"1/4	CR3201-0032 CR6146-0032
40	1"1/2	CR3201-0040 CR6146-0040
50	2"	CR3201-0050 CR6146-0050
65	2"1/2	CR3201-0065 CR6146-0065
80	3"	CR3201-0080 CR6146-0080
100	4"	CR3201-0100 CR6146-0100

CA1102

Clapet anti-pollution femelle BSP
Female BSP threaded antipollution check valve



Corps : Laiton CW617N brossé
Disque : Inox 304
Étanchéité : Joint FKM
Raccordement : Femelle BSP
Pression de service max :
Du 3/8" au 1" 25 bar
Du 1"1/4 au 2" 18 bar
Température de service max. :
-10°C/+100°C
Avec bouchon de purge amont et aval

Body: CW617N Brass
Disc: Inox 304
Seal: FKM
Connection: female BSP
Maximum working pressure:
3/8" to 1" 25 bar
1"1/4 to 2" 18 bar
Maximum working temperature:
-10°C/+100°C
With upstream and downstream drain plug

DN		L (mm)	Kg	Ref.
mm	inch			
10	3/8"	63	0,23	CA1102-0010
15	1/2"	68,5	0,24	CA1102-0015
20	3/4"	69,5	0,40	CA1102-0020
25	1"	79	0,46	CA1102-0025
32	1"1/4	84	0,67	CA1102-0032
40	1"1/2	93,5	0,98	CA1102-0040
50	2"	108	1,45	CA1102-0050



A placer après votre compteur d'eau : empêche le retour de l'eau dans le réseau de distribution (antipollution). Le CA1102 possède 2 bouchons : un en amont servant à contrôler l'étanchéité du clapet et un deuxième bouchon aval servant à contrôler la qualité de l'eau et éventuellement purger l'installation.
To be placed after you water meter: prevents water from returning into the distribution network (antipollution). The threaded type antipollution check valve CA1102 has two caps, one upstream for controlling the seal of the check valve and the other downstream for controlling the quality of the water and for purging the installation.

CA6469

Clapet axial anti-retour à ressort entre brides
Wafer type axial non-return check valve with spring



Corps : Inox A351 CF8M
Obturbateur : Inox A351 CF8M
Ressort : Inox 316
Étanchéité : Métal / métal
Guide et visserie : Inox 316
Raccordement :
Entre brides PN10/16/25/40/ASA150
Pression de service : 40 bar
Température de service : -60°C/+300°C
(conditions d'utilisation voir le passeport technique)

Body: Stainless steel A351 CF8M
Disc: Stainless steel A351 CF8M
Spring: Stainless steel 316
Seal: Metal / metal
Cover and bolts: Stainless steel 316
Connection:
Between flanges PN10/16/25/40/ASA150
Working pressure: 40 bar
Working temperature: -60°C/+300°C
(conditions of use see technical sheet)



Encombrement réduit, faibles pertes de charge
Small face to face, low head losses

DN		L (mm)	Kg	Ref.
mm	inch			
15	1/2"	16	0,11	CA6469-0015
20	3/4"	19	0,20	CA6469-0020
25	1"	22	0,30	CA6469-0025
32	1"1/4	28	0,50	CA6469-0032
40	1"1/2	32	0,60	CA6469-0040
50	2"	40	1	CA6469-0050
65	2" 1/2	46	1,35	CA6469-0065
80	3"	50	2	CA6469-0080
100	4"	60	3,2	CA6469-0100
125	5"	90	7,6	CA6469-0125
150	6"	106	11	CA6469-0150
200	8"	140	19	CA6469-0200
250	10"	145	28	CA6469-0250
300	12"	160	38	CA6469-0300

CA7441

Clapet axial à ressort entre brides
Wafer type axial type swing check valve

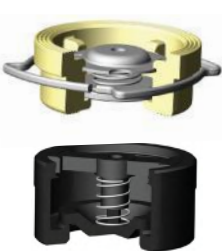

Corps : Laiton DN32-100
Fonte ductile GGG50 DN125-200
Disque : Inox DN32-100
Fonte ductile GGG50 DN125-200
Guide : Inox DN32-100
Fonte ductile GGG50 DN125-200
Ressort : Inox
Étanchéité : Métal / métal
Raccordement :
DN32-150: entre brides PN10/PN16
DN200: entre brides PN16
Pression de service max : 16 bar
Température de service : -10°C/+120°C

Body: Brass DN32-100
Ductile iron GGG50 DN125-200
Disc: Stainless steel DN32-100
Ductile iron GGG50 DN125-200
Guide: Stainless steel DN32-100
Ductile iron GGG50 DN125-200
Spring: Stainless steel
Seal: Metal / metal
Connection:
DN32-150: Between flanges PN10/PN16
DN200: between flanges PN16
Maximum working pressure: 16 bar
Working temperature: -10°C/+120°C

DN		L (mm)	Kg	Ref.
mm	inch			
32	1"1/4	28	0,46	CA7441-0032
40	1"1/2	31,5	0,62	CA7441-0040
50	2"	40	0,98	CA7441-0050
65	2"1/2	46	1,36	CA7441-0065
80	3"	50	2,08	CA7441-0080
100	4"	60	3,03	CA7441-0100
125	5"	90	6,80	CA7441-0125
150	6"	106	10	CA7441-0150
200	8"	140	20	CA7441-0200

CA6179 BSP | CA6779 NPT | CA6979 BW | CA6379 SW

Clapet 3 pièces toutes positions

Any position 3 pieces check valve

NEW

BIENTÔT DISPONIBLE - MARS 2021
COMING SOON - MARCH 2021

CA6979 DN50 - BW



ATEX II 2 GD C T2

Montage toutes positions
All mounting positions

Corps : Inox A351 CF8M
Disque : Inox AISI 316
Ressort : Inox 316
Étanchéité : Métal / métal
Raccordement :
CA6179-MM : Femelle BSP
CA6779-MM : Femelle NPT
CA6979-MM : A Souder en Bout BW
CA6379-MM : A Souder à emboîtement SW
Pression de service max : 63 bar
Température de service : -25°C/+180°C

Body: Stainless steel A351 CF8M
Disc: Stainless steel AISI 316
Spring: Stainless steel 316
Seal: Metal / metal
Connection:
CA6179-MM: female BSP
CA6779-MM: female NPT
CA6979-MM: Butt Welding
CA6379-MM: Socket Welding
Maximum working pressure: 63 bar
Working temperature: -25°C/+180°C

DN		L (mm)	Kg	Ref.
mm	inch			
8	1/4"	49	0,18	CA6179-MM0008 CA6779-MM0008 CA6979-MM0008 CA6379-MM0008
10	3/8"	49	0,18	CA6179-MM0010 CA6779-MM0010 CA6979-MM0010 CA6379-MM0010
15	1/2"	56	0,30	CA6179-MM0015 CA6779-MM0015 CA6979-MM0015 CA6379-MM0015
20	3/4"	65	0,43	CA6179-MM0020 CA6779-MM0020 CA6979-MM0020 CA6379-MM0020
25	1"	74	0,61	CA6179-MM0025 CA6779-MM0025 CA6979-MM0025 CA6379-MM0025
32	1 1/4"	83	1	CA6179-MM0032 CA6779-MM0032 CA6979-MM0032 CA6379-MM0032
40	1 1/2"	91	1,32	CA6179-MM0040 CA6779-MM0040 CA6979-MM0040 CA6379-MM0040
50	2"	110	2,14	CA6179-MM0050 CA6779-MM0050 CA6979-MM0050 CA6379-MM0050
65	2 1/2"	126	4	CA6179-MM0065 CA6779-MM0065 CA6979-MM0065 CA6379-MM0065
80	3"	141	5,71	CA6179-MM0080 CA6779-MM0080 CA6979-MM0080 CA6379-MM0080
100	4"	162	10	CA6179-MM0100 CA6779-MM0100 CA6979-MM0100 CA6379-MM0100

CA6190

Clapet à bille toutes positions taraudé

Female BSP all mounting positions ball check valve



Corps : Inox 316
Bille : Inox 316
Ressort : Inox 304
Étanchéité : Métal / métal
Raccordement : Femelle/Femelle BSP
Pression de service max : 400 bar
Température de service : -20°C/+180°C

Body: Stainless steel 316
Ball: Stainless steel 316
Spring: Stainless steel 304
Seal: Metal / metal
Connection: BSP female
Maximum working pressure: 400 bar
Working temperature: -20°C/+180°C

DN		L (mm)	Kg	Ref.
mm	inch			
8	1/4"	90	0,50	CA6190-0008
10	3/8"	90	0,50	CA6190-0010
15	1/2"	90	0,52	CA6190-0015
20	3/4"	130	0,88	CA6190-0020
25	1"	140	1,50	CA6190-0025



CA3241 | CA3201 | CA4208A | CA4248A

Clapet axial à brides PN10/PN16
Flanged type axial check valve PN10/PN16



Corps :
DN50-300 : Fonte EN-GJL-250 (GG25)
DN350-600 : Fonte ductile EN-GJS-400-15 (GGG40)
Disque : Fonte ductile EN-GJS-400-15 (GGG40)
Guide : Fonte ductile EN-GJS-400-15 (GGG40)
Ressort :
DN50-300 : Inox 316
DN350-600 : Inox 304
Étanchéité : Nitrile
Raccordement : À brides PN10, PN16
Pression de service max : 10 ou 16 bar
Température de service max : +100°C

Body:
DN50-300 : Cast iron EN-GJL-250 (GG25)
DN350-600 : Ductile iron EN-GJS-400-15 (GGG40)
Disc: Ductile iron EN-GJS-400-15 (GGG40)
Guide: Ductile iron EN-GJS-400-15 (GGG40)
Spring:
DN50-300: Stainless steel 316
DN350-600: Stainless steel 304
Seal: Nitrile
Connection: Flanged PN10, PN16
Maximum working pressure: 10 or 16 bar
Maximum working temperature: +100°C

DN				Kg	PN10	PN16
mm	inch	L (mm)	Ref.		Ref.	
50	2"	100	5,09	voir / see PN16		CA3241-0050
65	2" 1/2	120	7,85		CA3241-0065	
80	3"	140	9,53		CA3241-0080	
100	4"	170	13,2		CA3241-0100	
125	5"	200	20,5		CA3241-0125	
150	6"	230	29,6		CA3241-0150	
200	8"	300	47,3	CA3201-0200	CA3241-0200	
250	10"	370	68	CA3201-0250	CA3241-0250	
300	12"	410	112	CA3201-0300	CA3241-0300	
350	14"	425	180	CA4208A-0350	CA4248A-0350	
400	16"	475	240	CA4208A-0400	CA4248A-0400	
450	18"	-	-	CA4208A-0450	CA4248A-0450	
500	20"	587	380	CA4208A-0500	CA4248A-0500	
600	24"	710	590	CA4208A-0600	CA4248A-0600	

CLAPET/FILTRE
CHECK VALVE/STRAINER

PRODUIT ASSOCIÉ | RELATED PRODUCT

Crépine pour clapet axial à brides PN10 ou PN16
Strainer for flanged type axial check valve PN10 or PN16



Raccordement : Montage sur bride
Connection: Flange mounting

			Acier galvanisé / Galvanized steel	
DN			PN10	PN16
mm	inch		Ref.	Ref.
50	2"	voir / see PN16		CA3241CREPINE-0050
65	2" 1/2			CA3241CREPINE-0065
80	3"			CA3241CREPINE-0080
100	4"			CA3241CREPINE-0100
125	5"			CA3241CREPINE-0125
150	6"		CA3241CREPINE-0150	
200	8"	CR5200-0200	CA3241CREPINE-0200	CA3241CREPINE-0200
250	10"	CR5200-0250	CA3241CREPINE-0250	CA3241CREPINE-0250
300	12"	CR5200-0300	CA3241CREPINE-0300	CA3241CREPINE-0300
350	14"	CR5200-0350	CR5240-0350	CR5240-0350
400	16"	CR5200-0400	CR5240-0400	CR5240-0400
450	18"	CR5200-0450	CR5240-0450	CR5240-0450
500	20"	CR5200-0500	CR5240-0500	CR5240-0500
600	24"	CR5200-0600	CR5240-0600	CR5240-0600

			Inox 304 / Stainless steel 304	
DN			PN10	PN16
mm	inch		Ref.	Ref.
50	2"	voir / see PN16		CA3241CREPINOX-0050
65	2" 1/2			CA3241CREPINOX-0065
80	3"			CA3241CREPINOX-0080
100	4"			CA3241CREPINOX-0100
125	5"			CA3241CREPINOX-0125
150	6"			CA3241CREPINOX-0150
200	8"			CA3241CREPINOX-0200
250	10"			CA3241CREPINOX-0250
300	12"			CA3241CREPINOX-0300
350	14"		CR6200-0350	CR6240-0350
400	16"	CR6200-0400	CR6240-0400	CR6240-0400
450	18"	CR6200-0450	CR6240-0450	CR6240-0450
500	20"	CR6200-0500	CR6240-0500	CR6240-0500
600	24"	CR6200-0600	CR6240-0600	CR6240-0600

			Inox 316L / Stainless steel 316L		
DN			PN10	PN16	
mm	inch		Ref.	Ref.	
50	2"	voir / see PN16		CR6249-0050	
65	2" 1/2			CR6249-0065	
80	3"			CR6249-0080	
100	4"			CR6249-0100	
125	5"			CR6249-0125	
150	6"			CR6249-0150	
200	8"		CR6209-0200	CR6249-0200	CR6249-0200
250	10"		CR6209-0250	CR6249-0250	CR6249-0250
300	12"		CR6209-0300	CR6249-0300	CR6249-0300
350	14"		CR6209-0350	CR6249-0350	CR6249-0350
400	16"	CR6209-0400	CR6249-0400	CR6249-0400	
450	18"	CR6209-0450	CR6249-0450	CR6249-0450	
500	20"	CR6209-0500	CR6249-0500	CR6249-0500	
600	24"	CR6209-0600	CR6249-0600	CR6249-0600	

CA3242

Clapet toutes positions à brides

All mounting position flanged check valve



Corps : Fonte EN-GJL-250 Epoxy (GG25) ACS
Disque : Fonte ductile EN-GJS-400-15 (GG40)
Ressort : Inox 302
Etanchéité : EPDM ACS
Raccordement : A brides PN16 jusqu'au DN300 - PN10 au delà
Pression de service max : 16 bar
Température de service : -10°C / +120°C

Body: Cast iron EN-GJL-250 (GG25) Epoxy coated ACS
Disc: Ductile iron EN-GJS-400-15 (GG40)
Spring: Stainless steel 302
Seal: ACS EPDM
Connection: Flanged PN16 up through DN300, PN10 for all above
Maximum working pressure: 16 bar
Working temperature: -10°C / +120°C

DN		L (mm)	PN	Kg	Ref.
mm	inch				
50	2"	100	16	5,42	CA3242-0050
65	2" 1/2	120	16	8,22	CA3242-0065
80	3"	140	16	10,13	CA3242-0080
100	4"	165	16	13,53	CA3242-0100
125	5"	195	16	19,5	CA3242-0125
150	6"	230	16	27,07	CA3242-0150
200	8"	290	16	46,8	CA3242-0200
250	10"	355	16	77,2	CA3242-0250
300	12"	400	16	128	CA3242-0300
350	14"	480	10	260	CA3242-0350
400	16"	550	10	260	CA3242-0400
500	20"	680	10	500	CA3242-0500
600	24"	800	10	780	CA3242-0600

CA4251 | CA4261

Clapet axial à brides haute pression

High pressure axial type check valve



Corps : Fonte EN-GJS-400-15 (GGG40)
Clapet : Fonte EN-GJS-400-15 (GGG40)
Ressort : Inox 304
Etanchéité : NBR
Raccordement : A brides PN25 ou PN40
Pression de service max : 25 bar - 40 bar
Température de service max : -10°C / +80°C

Body: Ductile iron EN-GJS-400-15 (GGG40)
Disc: Ductile iron EN-GJS-400-15 (GGG40)
Spring: Stainless steel 304
Seal: NBR
Connection: Flanged PN25 or PN40
Maximum working pressure: 25 bar - 40 Bar
Maximum working temperature: -10°C / +80°C

DN			PN25		PN40	
mm	inch	L (mm)	Ref.	Kg	Ref.	Kg
50	2"	125	CA4251-0050	6	CA4261-0050	7
65	2" 1/2	145	CA4251-0065	8	CA4261-0065	9
80	3"	155	CA4251-0080	12	CA4261-0080	13
100	4"	175	CA4251-0100	17	CA4261-0100	19
125	5"	200	CA4251-0125	23	CA4261-0125	25
150	6"	225	CA4251-0150	35	CA4261-0150	39
200	8"	275	CA4251-0200	60	CA4261-0200	66
250	10"	325	CA4251-0250	95	CA4261-0250	105
300	12"	375	CA4251-0300	130	CA4261-0300	143
350	14"	425	CA4251-0350	180	CA4261-0350	198
400	16"	475	CA4251-0400	240	CA4261-0400	264
450	18"	500	CA4251-0450	264	CA4261-0450	-
500	20"	587	CA4251-0500	380	CA4261-0500	418
600	24"	710	CA4251-0600	590	CA4261-0600	650

Haute pression
High pressure

CEA5245 | CEA5205

Clapet d'entrée d'air acier carbone

Carbon steel air inlet check valve



Corps : Acier carbone ST37
Tige : Inox 304
Palier de guidage: Bronze
Siège : NBR
Raccordement : A brides PN10/16 suivant EN1092-1
Pression de service : 10/16 bar (voir tableau)
Body: Carbon Steel ST37 Epoxy coated
Stem: Inox 304
Bearing: Bronze
Seat: NBR
Connection: Flanged PN10/16
Working pressure: 10/16 bar (see chart)



DN		L (mm)	Kg	PN	Ref.
mm	inch				
50	2"	280	17	10/16	CEA5245-0050
80	3"	300	25	10/16	CEA5245-0080
100	4"	340	33	10/16	CEA5245-0100
150	6"	400	45	10/16	CEA5245-0150
200	8"	470	66	10	CEA5205-0200
			70	16	CEA5245-0200
250	10"	500	90	10	CEA5205-0250
			95	16	CEA5245-0250
300	12"	520	105	10	CEA5205-0300
			110	16	CEA5245-0300

A monter sur col de cygne
To mount on a goose neck



Permet l'entrée d'air à grand débit dans la conduite afin d'éviter une dépression en phase de vidange.
Allows a high-flow air intake into the pipe to prevent a vacuum from forming in the emptying phase.



CLAPETS À BOULE
BALL CHECK VALVES

CBL4141

Clapet à boule femelle BSP
Female BSP ball check valve



Corps : Fonte Ductile EN-GJS-500-7 (GGG50)
Boule :
DN 25-50 : Nitrile
DN 65 : Aluminium + Nitrile
Joint : Nitrile
Raccordement : Femelle BSP
Pression de service : 10 bar
Température de service : -10°C/+90°C

Body: Ductile Iron EN-GJS-500-7 (GGG50)
Ball:
DN 25-50: NBR
DN 65: Aluminium + NBR
O-ring: NBR
Connection: Female BSP
Working pressure: 10 bar
Working temperature: -10°C/+90°C

DN		L (mm)	Kg	Ref.
mm	inch			
25	1" *	125	1,3	CBL4141-0025 *
32	1"1/4	133	1,5	CBL4141-0032
40	1"1/2	151	2,1	CBL4141-0040
50	2"	175	3,2	CBL4141-0050
65	2"1/2	202	4,3	CBL4141-0065

* non CE / not CE

CBL4240

Clapet à boule à brides
Flanged type ball check valve



Corps : Fonte Ductile EN-GJS-500-7 (GGG50)
Boule :
DN40-50 : Nitrile
DN65-80 : Aluminium + Nitrile
DN100-400 : Fonte + Nitrile
Raccordement : A brides PN10
Pression de service : 10 bar
Température de service : -10°C/+80°C

Body: Ductile Iron EN-GJS-500-7 (GGG50)
Ball:
DN40-50: NBR
DN65-80: Aluminium + NBR
DN100-400: Cast Iron + NBR
Connection: Flanged PN10
Working pressure: 10 bar
Working temperature: -10°C/+80°C

DN		L (mm)	Kg	Ref.	DN		L (mm)	Kg	Ref.
mm	inch				mm	inch			
40	1" 1/2	180	5,6	CBL4240-0040	250	10"	600	125,3	CBL4240-0250
50	2"	200	7,5	CBL4240-0050	300	12"	700	177	CBL4240-0300
65	2" 1/2	240	10,1	CBL4240-0065	350	14"	800	276	CBL4240-0350
80	3"	260	12,8	CBL4240-0080	400	16"	900	423	CBL4240-0400
100	4"	300	18,4	CBL4240-0100	450*	18"	1000	500	CBL4240-0450
125	5"	350	30,2	CBL4240-0125	500*	20"	1100	680	CBL4240-0500
150	6"	400	38,5	CBL4240-0150	600 *	24"	1300	1095	CBL4240-0600
200	8"	500	76	CBL4240-0200					

* non CE / not CE



Anneau de levage sur le chapeau (jusqu'au DN400) équilibrant le clapet pour une manutention aisée lors de la pose de la conduite. Montage horizontal ou vertical avec fluide ascendant. Lifting hook on the bonnet (up to the DN400) for easy handling. Can be mounted horizontally or vertically but with flow going down to up.

PRODUITS ASSOCIÉS | RELATED PRODUCTS

CBL4240JOINT

Joint de chapeau pour clapet CBL4240
Bonnet gasket for CBL4240 ball check valve



Matière : NBR
Material: NBR

DN		Ref.	DN		Ref.
mm	inch		mm	inch	
40	1" 1/2	CBL4240JOINT-0040	150	6"	CBL4240JOINT-0150
50	2"	CBL4240JOINT-0050	200	8"	CBL4240JOINT-0200
65	2" 1/2	CBL4240JOINT-0065	250	10"	CBL4240JOINT-0250
80	3"	CBL4240JOINT-0080	300	12"	CBL4240JOINT-0300
100	4"	CBL4240JOINT-0100	350	14"	CBL4240JOINT-0350
125	5"	CBL4240JOINT-0125	400	16"	CBL4240JOINT-0400

DN450 au 600 sur demande / DN450 up to 600 on request

CBL4240BOU

Boule nitrile pour clapet CBL4240
Nitrile ball for CBL4240 ball check valve



Boule autonettoyante revêtue nitrile
Nitrile-coated self-cleaning steel ball

DN		Ref.	DN		Ref.
mm	inch		mm	inch	
40	1" 1/2	CBL4240BOU-NI0040	150	6"	CBL4240BOU-NI0150
50	2"	CBL4240BOU-NI0050	200	8"	CBL4240BOU-NI0200
65	2" 1/2	CBL4240BOU-NI0065	250	10"	CBL4240BOU-NI0250
80	3"	CBL4240BOU-NI0080	300	12"	CBL4240BOU-NI0300
100	4"	CBL4240BOU-NI0100	350	14"	CBL4240BOU-NI0350
125	5"	CBL4240BOU-NI0125	400	16"	CBL4240BOU-NI0400

DN450 au 600 sur demande / DN450 up to 600 on request

CBL4230

ASA 150

Clapet à boule à brides en fonte ductile - ASA150

Flanged Ductile iron ball check valve - ASA150



Corps et chapeau :
Fonte ductile EN-GJS-500-7 (GGG50)
Boule : Fonte revêtue Nitrile
Joint de chapeau : Nitrile
Raccordement : À brides ASA150
Pression de service : 10 bar
Température de service : -10°C/+80°C

NEW

Body and cover: Ductile iron EN-GJS-500-7 (GGG50)
Ball: NBR
O-ring: NBR
Connection: Flanged ASA150
Working pressure: 10 bar
Working temperature: -10°C/+80°C

DN		L (mm)	Kg	Ref.
mm	inch			
40	1" 1/2	180	5,6	CBL4230-0040
50	2"	200	7,5	CBL4230-0050
65	2" 1/2	240	10,1	CBL4230-0065
80	3"	260	12,8	CBL4230-0080
100	4"	300	18,4	CBL4230-0100
125	5"	350	30,2	CBL4230-0125
150	6"	400	38,5	CBL4230-0150
200	8"	500	76	CBL4230-0200
250	10"	600	125,3	CBL4230-0250



**Anneau de levage sur le chapeau équilibrant le clapet pour une manutention aisée lors de la pose de la conduite.
Montage horizontal ou vertical avec fluide ascendant.
Lifting hook on the bonnet for easy handling.
Can be mounted horizontally or vertically but with flow going down to up.**

CBL420G

Application abrasive | Abrasive application

Clapet à boule application abrasive - PN10

Flanged Ductile iron ball check valve for abrasive application - PN10



Corps et chapeau :
Fonte ductile EN-GJS400-15 revêtue de gomme naturelle anti-abrasive
Boule : Polyuréthane
Boulonnerie : Acier inoxydable A2
Raccordement : À brides PN10
Pression de service max: 10 bar
Température de service : -10°C/+80°C

NEW

Body and cover:
Ductile iron EN-GJS400-15 with anti-abrasive rubber lining
Ball: Polyurethane
Bolts: Stainless steel A2
Connection: Flanged PN10
Maximum working pressure: 10 bar
Working temperature: -10°C/+80°C

DN		L (mm)	Kg	Ref.
mm	inch			
100	4"	300	21,5	CBL420G-0100
125	5"	350	36	CBL420G-0125
150	6"	400	45	CBL420G-0150
200	8"	500	80	CBL420G-0200
250	10"	600	120	CBL420G-0250
300	12"	700	180	CBL420G-0300
350	14"	800	270	CBL420G-0350
400	16"	900	440	CBL420G-0400
500	20"	1100	680	CBL420G-0500



**Application abrasive
Abrasive application**

CBL6149

Clapet à boule femelle BSP

Female BSP ball check valve



Corps : Inox 316 embouti
Boule : Aluminium revêtu FPM
Joint : FPM
Raccordement : Femelle BSP
Pression de service : 16 bar
Température de service : +150°C

Body: Stamped Stainless steel 316
Ball: Aluminium FPM coated
O-ring: FPM
Connection: Female BSP
Working pressure: 16 bar
Working temperature: +150°C

DN		L (mm)	Kg	Ref.
mm	inch			
32	1" 1/4	175	1,1	CBL6149-0032
40	1" 1/2	190	1,18	CBL6149-0040
50	2"	210	1,61	CBL6149-0050

CBL6240

Clapet à boule à brides Inox

Flanges Stainless steel ball check valve



Corps :
DN 50-200 : Inox 316
DN 250-400 : Inox 316
Boule : Aluminium + Nitrile
Joint : Nitrile
Raccordement : À brides PN10 ou PN16
Pression de service : 16 bar jusqu'au DN150
10 bar à partir du DN200
Température de service : -10°C/+80°C

NEW

Body:
DN 50-200: Stainless steel 316
DN 250-400: Stainless steel 316
Ball: Aluminium + NBR
O-ring: NBR
Connection: Flanged PN10 or PN16
Working pressure: 16 bar until DN150
10 bar from DN200
Working temperature: -10°C/+80°C

DN		L (mm)	Kg	Ref.
mm	inch			
50	2"	200	8,5	CBL6240-0050
65	2" 1/2	240	12,5	CBL6240-0065
80	3"	260	15,6	CBL6240-0080
100	4"	300	21	CBL6240-0100
125	5"	350	30	CBL6240-0125
150	6"	400	41	CBL6240-0150
200	8"	500	69	CBL6240-0200

CE





CLAPETS À BATTANT SWING CHECK VALVES

CB1102

Clapet de retenue à battant laiton femelle BSP
Female BSP brass swing check valve



Corps : Laiton
Battant : Laiton
Axe : Laiton
Étanchéité :
Du 3/8" au 2" Metal / EPDM
Du 2"1/2 au 4" Metal / NBR
Raccordement : Femelle BSP
Pression de service max : 10 bar
Température de service : 0°C/+60°C

Body: Brass
Disc: Brass
Stem: Brass
Seal:
3/8" to 2" Metal/EPDM
2"1/2 to 4" Metal/NBR
Connection: Female BSP
Maximum working pressure: 10 bar
Working temperature: 0°C/+60°C

DN		L (mm)	Kg	Ref.
mm	inch			
10	3/8"	47	0,182	CB1102-0010
15	1/2"	47	0,158	CB1102-0015
20	3/4"	53	0,231	CB1102-0020
25	1"	63	0,370	CB1102-0025
32	1"1/4	74	0,554	CB1102-0032
40	1"1/2	87	0,726	CB1102-0040
50	2"	97	1,268	CB1102-0050
65	2"1/2	116	1,579	CB1102-0065
80	3"	135	2,253	CB1102-0080
100	4"	164	3,837	CB1102-0100

CB2143

Clapet de retenue à battant bronze femelle BSP
Female BSP bronze swing check valve



Corps : Bronze
Battant : Bronze
Étanchéité : Nitrile
Raccordement : Femelle BSP
Pression de service : 20 bar
Température de service max : +80°C

Body: Bronze
Disc: Bronze
Seal: Nitrile
Connection: Female BSP
Working pressure: 20 bar
Maximum Working temperature: +80°C

**JUSQU'À ÉPUISEMENT DES STOCKS
WHILE STOCKS LAST**

DN		L (mm)	Kg	Ref.
mm	inch			
15	1/2"	49	0,16	CB2143-0015
20	3/4"	58	0,23	CB2143-0020
25	1"	68	0,27	CB2143-0025
32	1"1/4	76	0,55	CB2143-0032
50	2"	103	1,13	CB2143-0050

CB2143W

Clapet de retenue à battant bronze femelle BSP - WRAS
Female BSP bronze swing check valve - WRAS



Corps : Bronze
Clapet : Nitrile
Raccordement : Femelle BSP
Pression de service : 20 bar
Température de service max :
-10°C / + 100°C

Body: Bronze
Disc: NBR
Connection: Female BSP
Working pressure: 20 bar
Maximum Working temperature:
-10°C / + 100°C

**BIENTÔT DISPONIBLE
COMING SOON**



DN		L (mm)	Kg	Ref.
mm	inch			
15	1/2"	58	0,25	CB2143W-0015
20	3/4"	66	0,38	CB2143W-0020
25	1"	76	0,60	CB2143W-0025
32	1"1/4	88	0,87	CB2143W-0032
40	1"1/2	96	1,15	CB2143W-0040
50	2"	112	1,79	CB2143W-0050

CB6140

Clapet de retenue à battant Inox femelle BSP
Female BSP Stainless steel swing check valve



Corps : ASTM A351 CF8M
Battant : ASTM A182 F304
Axe : ASTM A182 F304
Étanchéité : Métal/métal
Raccordement : Femelle BSP
Pression de service max : 16 bar
Température de service : -20°C/+200°C

Body: ASTM A351 CF8M
Disc: ASTM A182 F304
Stem: ASTM A182 F304
Seal: Metal/metal
Connection: female BSP
Maximum working pressure: 16 bar
Working temperature: -20°C/+200°C

DN		L (mm)	Kg	Ref.
mm	inch			
8	1/4"	65	0,264	CB6140-0008
10	3/8"	65	0,280	CB6140-0010
15	1/2"	65	0,320	CB6140-0015
20	3/4"	80	0,530	CB6140-0020
25	1"	90	0,750	CB6140-0025
32	1"1/4	103	1,030	CB6140-0032
40	1"1/2	120	1,590	CB6140-0040
50	2"	141	2,310	CB6140-0050

CB3240PN10 | CB3240PN16

Etanchéité M/M | M/M seal

Clapet à battant à brides
Flanged type swing check valve



Corps : Fonte EN-GJL-250 (GG25)
Battant : Fonte EN-GJL-250 (GG25)
Etanchéité : Laiton / laiton
Raccordement : À brides PN10 et PN16
Pression de service : 10 bar - 16 bar
Température de service max : +150°C

Body: Cast iron EN-GJL-250 (GG25)
Disc: Cast iron EN-GJL-250 (GG25)
Seal: Brass / brass
Connection: Flanged PN10 and PN16
Working pressure: 10 bar - 16 bar
Maximum Working temperature: +150°C

DN		L (mm)	Kg	Ref.
mm	inch			
40	1"1/2	180	9	CB3240PN16-0040
50	2"	200	12	CB3240PN16-0050
65	2"1/2	240	16	CB3240PN16-0065
80	3"	260	20	CB3240PN16-0080
100	4"	300	27	CB3240PN16-0100
125	5"	350	42	CB3240PN16-0125
150	6"	400	58	CB3240PN16-0150
200	8"	500	93	CB3240PN10-0200 CB3240PN16-0200
250	10"	600	155	CB3240PN10-0250 CB3240PN16-0250
300	12"	700	221	CB3240PN10-0300 CB3240PN16-0300
350	14"	800	306	CB3240PN10-0350 Ⓞ CB3240PN16-0350
400	16"	900	430	CB3240PN10-0400 Ⓞ CB3240PN16-0400

CB3241PN10 | CB3241PN16

Etanchéité EPDM | EPDM seal

Clapet à battant à brides
Flanged type swing check valve



Corps : Fonte EN-GJL -250 (GG25)
Battants : Fonte EN-GJL -250 (GG25)
Etanchéité : EPDM
Raccordement : A brides PN16
Pression de service max : 16 bar
Température de service max : -10°C/80°C

Body: Cast iron EN-GJL -250 (GG25)
Disc: Cast iron EN-GJL -250 (GG25)
Seal: EPDM
Connection: Flanged PN16
Maximum working pressure: 16 bar
Maximum working temperature: -10°C/80°C

DN		L (mm)	Kg	Ref.
mm	inch			
40	1"1/2	180	9	CB3241PN16-0040
50	2"	200	12	CB3241PN16-0050
65	2"1/2	240	16	CB3241PN16-0065
80	3"	260	20	CB3241PN16-0080
100	4"	300	27	CB3241PN16-0100
125	5"	350	42	CB3241PN16-0125
150	6"	400	58	CB3241PN16-0150
200	8"	500	93	CB3241PN16-0200 CB3241PN10-0200
250	10"	600	155	CB3241PN16-0250 CB3241PN10-0250 Ⓞ
300	12"	700	221	CB3241PN16-0300 CB3241PN10-0300 Ⓞ
350	14"	800	306	CB3241PN16-0350 CB3241PN10-0350 Ⓞ
400	16"	900	430	CB3241PN16-0400 CB3241PN10-0400 Ⓞ

CB4251

Haute pression | High pressure

Clapet à battant à brides PN25
Flanged PN25 swing check valve



Corps & chapeau : Fonte EN-GJS-400-15 (GGG40)
Siège : Alliage cuivreux
Axe de manoeuvre : Acier Inoxydable 420
Visserie : Acier galvanisé CLASSE 8.8
Raccordement : A brides PN25
Température de service : -10°C / +80°C

Body & Cover: Ductile Iron EN-GJS-400-15 (GGG40)
Seat: Copper alloy
Shaft: Stainless steel 420
Bolts and nuts: Carbon steel galvanized 8.8
Connection: Flanged PN25
Working temperature: -10°C / +80°C

	DN		L (mm)	Kg	Ref.	
	mm	inch				
Battant Acier carbone revêtu EPDM	40	1" 1/2	180	10	CB4251-0040	
	50	2"	200	13	CB4251-0050	
	65	2" 1/2	240	21	CB4251-0065	
	80	3"	260	22	CB4251-0080	
	100	4"	300	25	CB4251-0100	
	125	5"	350	40	CB4251-0125	
	Disc Carbon steel with EPDM coating	150	6"	400	52	CB4251-0150
		200	8"	450	149	CB4251-0200
		250	10"	600	182	CB4251-0250
		300	12"	700	316	CB4251-0300
350		14"	800	432	CB4251-0350	
400		16"	900	550	CB4251-0400	
Battant Disc GGG40		450	18"	1000	670	CB4251-0450
		500	20"	1100	880	CB4251-0500
	600	24"	1300	1102	CB4251-0600	
	700	28"	1500	1800	CB4251-0700	
	800	32"	1700	2250	CB4251-0800	



CB4261

Haute pression | High pressure

Clapet à battant à brides PN40
Flanged PN40 swing check valve



Corps & chapeau : Fonte EN-GJS-400-15 (GGG40)
Siège : Alliage cuivreux
Axe de manoeuvre : Acier Inoxydable 420
Visserie : Acier galvanisé CLASSE 8.8
Raccordement : A brides PN40
Température de service : -10°C / +80°C

Body & Cover: Ductile Iron EN-GJS-400-15 (GGG40)
Seat: Copper alloy
Shaft: Stainless steel 420
Bolts and nuts: Carbon steel galvanized 8.8
Connection: Flanged PN40
Working temperature: -10°C / +80°C

	DN		L (mm)	Kg	Ref.
	mm	inch			
Battant Acier carbone revêtu EPDM	40	1" 1/2	180	11	CB4261-0040
	50	2"	200	14	CB4261-0050
	65	2" 1/2	240	23	CB4261-0065
	80	3"	260	24	CB4261-0080
	100	4"	300	28	CB4261-0100
	125	5"	350	43	CB4261-0125
	150	6"	400	56	CB4261-0150
	200	8"	450	162	CB4261-0200
	250	10"	600	198	CB4261-0250
	300	12"	700	344	CB4261-0300
Disc steel with EPDM coating	350	14"	800	472	CB4261-0350
	400	16"	900	600	CB4261-0400
	450	18"	1000	755	CB4261-0450
	500	20"	1100	960	CB4261-0500
Battant Disc GGG40	600	24"	1300	1200	CB4261-0600
	700	28"	1500	1800	CB4261-0700
	800	32"	1700	2250	CB4261-0800

CB4205 | 08 | 45 | 48 | 55 | 58 | 65 | 68

Clapet à battant à contrepoids | Swing check valve with counterweight

Clapet à battant à brides à contrepoids
Flanged type swing check valve with counterweight



Corps & chapeau : Fonte ductile EN-GJS-400-15 (GGG40)
Siège : Alliage cuivreux
Axe de manoeuvre : Acier Inoxydable 420
Visserie : Acier galvanisé CLASSE 8.8
Lever : Acier carbone
Contrepoids : Fonte ductile EN-GJS-400-15 (GGG40)
Raccordement : A brides (PN voir tableaux)
Température de service : -10°C / +80°C

Body & Cover: Ductile Iron EN-GJS-400-15 (GGG40)
Seat: Copper alloy
Shaft: Stainless steel 420
Bolts and nuts: Carbon steel galvanized 8.8
Lever: Carbon steel
Counterweight: Fonte EN-GJS-400-15 (GGG40)
Connection: Flanged (PN see charts)
Working temperature: -10°C / +80°C

	DN		L (mm)	Kg	PN10	PN16	
	mm	inch			Ref.	Ref.	
Battant Acier carbone revêtu EPDM	40	1" 1/2	180	10	voir / see PN16	CB4245-0040	
	50	2"	200	15		CB4245-0050	
	65	2" 1/2	240	20		CB4245-0065	
	80	3"	260	21		CB4245-0080	
	100	4"	300	33		CB4245-0100	
	125	5"	350	55		CB4245-0125	
	150	6"	400	75		CB4245-0150	
	200	8"	500	126		CB4205-0200	CB4245-0200
	250	10"	600	160		CB4205-0250	CB4245-0250
	300	12"	700	240		CB4205-0300	CB4245-0300
Disc Carbon steel with EPDM coating	350	14"	800	315	CB4205-0350	CB4245-0350	
	400	16"	900	530	CB4205-0400	CB4245-0400	
	450	18"	1000	650	CB4208-0450	CB4248-0450	
	500	20"	1100	830	CB4208-0500	CB4248-0500	
Battant Disc GGG40	600	24"	1300	1050	CB4208-0600	CB4248-0600	
	700	28"	1500	1600	CB4208-0700	CB4248-0700	
	800	32"	1700	2150	CB4208-0800	CB4248-0800	
	1000	40"	2100	3680	CB4208-1000	CB4248-1000	

	DN		L (mm)	PN25		PN40	
	mm	inch		Ref.	Kg	Ref.	Kg
Battant Acier carbone revêtu EPDM	40	1" 1/2	180	CB4255-0040	12	CB4265-0040	16
	50	2"	200	CB4255-0050	17	CB4265-0050	22
	65	2" 1/2	240	CB4255-0065	22	CB4265-0065	30
	80	3"	260	CB4255-0080	25	CB4265-0080	33
	100	4"	300	CB4255-0100	35	CB4265-0100	40
	125	5"	350	CB4255-0125	58	CB4265-0125	63
	150	6"	400	CB4255-0150	78	CB4265-0150	85
	200	8"	500	CB4255-0200	149	CB4265-0200	176
	250	10"	600	CB4255-0250	170	CB4265-0250	200
	300	12"	700	CB4255-0300	390	CB4265-0300	396
Disc Carbon steel with EPDM coated	350	14"	800	CB4255-0350	435	CB4265-0350	475
	400	16"	900	CB4255-0400	650	CB4265-0400	656
	450	18"	1000	CB4258-0450	680	CB4268-0450	760
	500	20"	1100	CB4258-0500	890	CB4268-0500	966
Battant Disc GGG40	600	24"	1300	CB4258-0600	1150	CB4268-0600	1250
	700	28"	1500	CB4258-0700	1680	CB4268-0700	-
	800	32"	1700	CB4258-0800	2300	CB4268-0800	-
	1000	40"	2100	CB4258-1000	3150	CB4268-1000	-



Contactez-nous pour toute demande de **position verticale**; nous préciser la position du clapet lors de votre demande (position livrée en horizontal en standard) ainsi que l'environnement amont/aval du clapet pour vous préconiser l'équipement le plus adapté.

Contact us for any vertical position requests: please specify the position of the check valve (position delivered horizontally as standard) as well as the upstream / downstream environment of the valve to recommend the most suitable equipment.



CLAPETS SANDWICH SWING CHECK VALVES

CB5440

Acier | Steel

Clapet sandwich entre brides acier
Steel wafer type swing check valve



Corps et battant : Acier zingué
Etanchéité : EPDM
Raccordement :
Entre-brides PN10/16 jusqu'au DN150
Entre-brides PN16 à partir du DN200
Pression de service : 16 bar jusqu'au DN150
10 bar du DN200 au DN300
Température de service max : +110°C

Body and Disc: Steel

Seal: EPDM

Connection:

Between flanges PN10/16 up to DN150

Between flanges PN16 from DN200

Working pressure: 16 bar DN40 to DN150

10 bar DN200 to DN300

Maximum Working temperature: +110°C

DN		L (mm)	Kg	Ref.
mm	inch			
40	1" 1/2	16	0,74	CB5440-0040
50	2"	16	0,97	CB5440-0050
65	2" 1/2	16	1,34	CB5440-0065
80	3"	16	1,6	CB5440-0080
100	4"	16	1,99	CB5440-0100
125	5"	16	2,77	CB5440-0125
150	6"	19	4,06	CB5440-0150
200	8"	22	7,11	CB5440-0200
250	10"	32	14,9	CB5440-0250
300	12"	38	21,8	CB5440-0300
350	14"	38	30,1	CB5440-0350
400	16"	44	42,5	CB5440-0400
450	18"	50	68	CB5440-0450
500	20"	56	93	CB5440-0500
600	24"	62	139	CB5440-0600

CB6441

Inox | Stainless steel

Clapet sandwich entre brides inox
Stainless steel wafer type swing check valve



Corps et battant : Inox 316
Etanchéité : FPM
Raccordement :
Entre-brides PN10/16 jusqu'au DN150
Entre-brides PN16 à partir du DN200
Pression de service : 16 bar
Température de service max : +170°C

Body and Disc: Stainless Steel 316

Seal: FPM

Connection:

Between flanges PN10/16 up to DN150

Between flanges PN16 from DN200

Working pressure: 16 bar

Maximum Working temperature: +170°C

DN		L (mm)	Kg	Ref.
mm	inch			
40	1" 1/2	16	0,77	CB6441-0040
50	2"	16	1	CB6441-0050
65	2" 1/2	16	1,38	CB6441-0065
80	3"	16	1,65	CB6441-0080
100	4"	16	2,02	CB6441-0100
125	5"	16	2,83	CB6441-0125
150	6"	19	4,10	CB6441-0150
200	8"	22	7,18	CB6441-0200
250	10"	32	15,1	CB6441-0250
300	12"	38	22,3	CB6441-0300
350	14"	38	30,2	CB6441-0350
400	16"	44	43,5	CB6441-0400
450	18"	50	68	CB6441-0450
500	20"	56	93	CB6441-0500
600	24"	62	139	CB6441-0600

CE

CB6441-EPA

ACS

Clapet sandwich entre brides inox
Stainless steel wafer type swing check valve



Corps et battant : Inox 316
Etanchéité : EPDM ACS
Raccordement :
Entre-brides PN10/16 jusqu'au DN150
Entre-brides PN16 à partir du DN200
Pression de service : 16 bar jusqu'au DN150
10 bar du DN200 au DN300
Température de service : -10°C/+110°C

Body and Disc: Stainless Steel 316

Seal: EPDM ACS

Connection:

Between flanges PN10/16 up to DN150

Between flanges PN16 from DN200

Working pressure: 16 bar DN40 to DN150

10 bar DN200 to DN300

Maximum Working temperature: -10°C/+110°C

DN		PN	L (mm)	Kg	Ref.
mm	inch				
40	1" 1/2	16	16	0,78	CB6441-EPA0040
50	2"	16	16	0,93	CB6441-EPA0050
65	2" 1/2	16	16	1,39	CB6441-EPA0065
80	3"	16	16	1,67	CB6441-EPA0080
100	4"	16	16	2,03	CB6441-EPA0100
125	5"	16	16	2,90	CB6441-EPA0125
150	6"	16	19	4,39	CB6441-EPA0150
200	8"	10	22	9,04	CB6441-EPA0200
250	10"	10	32	15,45	CB6441-EPA0250
300	12"	10	38	23,95	CB6441-EPA0300

CE ACS





CLAPETS À DOUBLE BATTANT DUAL PLATE CHECK VALVES

CB3448N-EP

Battant fonte ductile | Ductile iron plate

Clapet double battant PN16 - battant fonte ductile

Dual plate check valve PN16 - Ductile iron plate



CE



Corps : Fonte GG25
Battant : Fonte ductile chromé
Axe : Inox 410
Ressorts : Inox 304
Étanchéité : EPDM
Pression de service : 16 bar
Raccordement : Entre-brides
DN40-600 : PN10/16
DN700-800 : PN16
Température de service max : +110°C

Body: Cast Iron GG25
Plate: Ductile iron chromed
Shaft: Stainless steel 410
Springs: Stainless steel 304
Seal: EPDM
Working pressure: 16 bar
Connection: Between flanges
DN40-600: PN10/16
DN700-800: PN16
Maximum Working temperature: +110°C

DN		L (mm)	Kg	Ref.
mm	inch			
40	1" 1/2	43	1	CB3448N-EP0040
50	2"	43	1,3	CB3448N-EP0050
65	2" 1/2	46	1,8	CB3448N-EP0065
80	3"	64	3	CB3448N-EP0080
100	4"	64	3,9	CB3448N-EP0100
125	5"	70	5,7	CB3448N-EP0125
150	6"	76	8	CB3448N-EP0150
200	8"	89	14,3	CB3448N-EP0200
250	10"	114	24,9	CB3448N-EP0250
300	12"	114	33,5	CB3448N-EP0300
350	14"	127	55	CB3448N-EP0350
400	16"	140	75	CB3448N-EP0400
450	18"	152	101	CB3448N-EP0450
500	20"	152	111	CB3448N-EP0500
600	24"	178	172	CB3448N-EP0600
700	20"	229	291	CB3448N-EP0700 Ⓞ
800	24"	241	390	CB3448N-EP0800 Ⓞ

CB3449-EPA

ACS

Clapet double battant ACS

ACS dual plate check valve

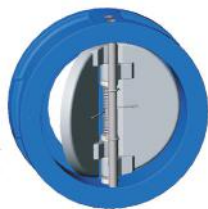

ACS



Corps : Fonte GG25
Battant : Inox 316
Axe : Inox 410
Ressorts : Inox 304
Étanchéité : EPDM ACS
Raccordement : Entre-Brides PN10/16
Pression de service : 16 bar
Température de service max : +110°C

Body: Cast Iron GG25
Plate: Stainless Steel 316
Shaft: Stainless steel 410
Springs: Stainless steel 304
Seal: EPDM ACS
Connection: Between flanges PN10/16
Working pressure: 16 bar
Maximum Working temperature: +110°C

DN		L (mm)	Kg	Ref.
mm	inch			
40	1" 1/2	43	1	CB3449-EPA0040
50	2"	43	1,6	CB3449-EPA0050
65	2" 1/2	46	2,4	CB3449-EPA0065
80	3"	64	3,7	CB3449-EPA0080
100	4"	64	4,8	CB3449-EPA0100
125	5"	70	6,7	CB3449-EPA0125
150	6"	76	9	CB3449-EPA0150
200	8"	89	15,6	CB3449-EPA0200
250	10"	114	26,9	CB3449-EPA0250
300	12"	114	36,8	CB3449-EPA0300
350	14"	127	55	CB3449-EPA0350 Ⓞ
400	16"	140	73	CB3449-EPA0400 Ⓞ
450	18"	152	99	CB3449-EPA0450 Ⓞ
500	20"	152	117	CB3449-EPA0500 Ⓞ
600	24"	178	177	CB3449-EPA0600 Ⓞ

CB4450

PN25

Clapet double battant PN25 - battant fonte ductile

Dual plate check valve PN25 - ductile iron plate

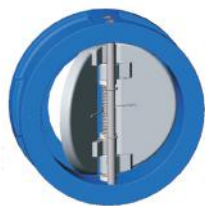

Corps : Fonte Ductile GGG40
 Battant : GGG40 chromé
 Axe : Inox 416
 Ressorts : Inox 304
 Etanchéité : EPDM
 Raccordement : Entre-Brides PN25
 Pression de service : 25 bar
 Température de service max : +110°C

Body: Ductile Iron GGG40
 Plate: GGG40 chromed
 Shaft: Stainless steel 416
 Springs: Stainless steel 304
 Seal: EPDM
 Connection: Between flanges PN25
 Working pressure: 25 bar
 Maximum working temperature: +110°C

DN		L (mm)	Kg	Ref.
mm	inch			
40	1" 1/2	43	1,9	CB4450-0040
50	2"	43	2,2	CB4450-0050
65	2" 1/2	46	3,3	CB4450-0065
80	3"	64	4,3	CB4450-0080
100	4"	64	6,6	CB4450-0100
125	5"	70	10,9	CB4450-0125
150	6"	76	12,9	CB4450-0150
200	8"	89	20,1	CB4450-0200
250	10"	114	31,4	CB4450-0250
300	12"	114	50	CB4450-0300
350	14"	127	80	CB4450-0350
400	16"	140	115	CB4450-0400
450	18"	152	145	CB4450-0450
500	20"	152	175	CB4450-0500
600	24"	178	245	CB4450-0600

CB4435 | CB4439 | CB4438

ASA 150

Clapet double battant ASA150

Dual plate check valve ASA150

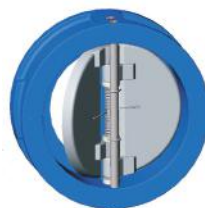

Corps : Fonte Ductile GGG40
 Raccordement : Entre brides ASA150Lbs
 Pression de service : 20 bar
 Température de service max : +100°C

Body: Ductile Iron GGG40
 Connection: Between flanges ASA150Lbs
 Working pressure: 20 bar
 Maximum working temperature: +100°C



DN		L (mm)	Kg	Ref.
mm	inch			
50	2"	43	1,3	CB4435-0050
65	2" 1/2	46	1,8	CB4435-0065
80	3"	64	3,5	CB4435-0080
100	4"	64	4	CB4435-0100
125	5"	70	6	CB4435-0125
150	6"	76	8,5	CB4435-0150
200	8"	89	15	CB4435-0200
250	10"	114	28	CB4439-0250
300	12"	114	37	CB4439-0300
350	14"	127	52	CB4439-0350
400	16"	140	75	CB4439-0400
450	18"	152	95	CB4438-0450
500	20"	152	125	CB4438-0500
600	24"	178	180	CB4438-0600

Battant : Acier A216WCB chromé
Joint : NBR

Plate : Steel A216WCB
Seal : NBR

Battant : CF8M
Joint : EPDM

Plate : CF8M
Seal : EPDM

Battant : Fonte GGG40
Joint : NBR

Plate : Iron GGG40
Seal : NBR

CB3442

Battant bronze aluminium | Aluminium bronze plate

Clapet double battant PN16 – battant bronze aluminium

Ductile iron dual plate swing check valve PN16 – aluminium bronze plate



Corps : Fonte Ductile EN-GJS-400-15
 Battant : Bronze aluminium
 Axe : Inox 316
 Ressorts : Inox 316
 Etanchéité : NBR vulcanisé
 Raccordement : Entre brides PN10/16
 Pression de service : 16 bar
 Température de service max : +80°C

Body: Ductile Iron EN-GJS-400-15
 Plate: Aluminium bronze
 Shaft: Stainless steel 316
 Springs: Stainless steel 316
 Seal: NBR
 Connection: Between flanges PN10/16
 Working pressure: 16 bar
 Working temperature: +80°C

DN		L (mm)	Kg	Ref.
mm	inch			
50	2"	54	1,65	CB3442-0050
65	2" 1/2	54	2,4	CB3442-0065
80	3"	57	3,1	CB3442-0080
100	4"	64	4,85	CB3442-0100
125	5"	70	6,4	CB3442-0125
150	6"	76	9,1	CB3442-0150
200	8"	95	16,9	CB3442-0200
250	10"	108	27,5	CB3442-0250
300	12"	144	35,9	CB3442-0300
350	14"	184	81	CB3442-0350



CB6442

Inox PN16 | Stainless steel PN16

Clapet double battant PN16 - inox

Dual plate check valve [PN16 - Stainless steel](#)

Corps et battant : Inox 316
 Axe : Inox 316
 Etanchéité : FPM
 Raccordement :
 DN50-200 : entre brides PN25
 DN250-600 : entre brides PN10/16
 Pression de service max :
 DN50 à DN300 : 16 bar
 DN350 à DN600 : 10 bar
 Température de service : -10°C/+180°C

Body and plate: Stainless steel 316
 Shaft: Stainless steel 316
 Seal: FPM
 Connection:
 DN50-200: between flanges PN25
 DN250-600: between flanges PN 10/16
 Working pressure:
 DN50-300: 16 bar
 DN350-600: 10 bar
 Working temperature: -10°C/+180°C

DN		PS	L (mm)	Kg	Ref.
mm	inch				
50	2"	16	54	1,84	CB6442-0050
65	2" 1/2	16	54	2,04	CB6442-0065
80	3"	16	57	3,35	CB6442-0080
100	4"	16	64	5,05	CB6442-0100
125	5"	16	70	6,68	CB6442-0125
150	6"	16	76	9,6	CB6442-0150
200	8"	16	95	18,07	CB6442-0200
250	10"	16	108	26,9	CB6442-0250
300	12"	16	144	38,9	CB6442-0300
350	14"	10	184	80	CB6442-0350
400	16"	10	191	106	CB6442-0400
450	18"	10	203	128	CB6442-0450
500	20"	10	213	158	CB6442-0500
600	24"	10	222	225	CB6442-0600

CB6450

Inox PN25 | Stainless steel PN25

Clapet double battant PN25 - inox

Dual plate swing check valve [PN25 - Stainless steel](#)

Corps et battant : Inox 316
 Axe : Inox 316
 Etanchéité : FPM
 Raccordement : Entre-Brides PN25
 Pression de service : 25 bar
 Température de service max : +200°C

Body and plate: Stainless steel 316
 Shaft: Stainless steel 316
 Seal: FPM
 Connection: Between flanges PN25
 Working pressure: 25 bar
 Maximum working temperature: +200°C

* sur demande / on request

DN		L (mm)	Kg	Ref.
mm	inch			
50	2"	43	1,2	CB6450-0050
65	2" 1/2	46	1,9	CB6450-0065
80	3"	64	3	CB6450-0080
100	4"	64	4	CB6450-0100
125	5"	70	6	CB6450-0125
150	6"	76	8,5	CB6450-0150
200	8"	89	15	CB6450-0200
250	10"	114	*	CB6450-0250
300	12"	114	*	CB6450-0300
350	14"	127	56	CB6450-0350
400	16"	140	73	CB6450-0400
450	18"	152	98	CB6450-0450
500	20"	152	127	CB6450-0400
600	24"	178	193	CB6450-0600



CLAPETS À SOUPE LIFT CHECK VALVES

CS2142 | CS2143

Clapet de retenue à soupape à chapeau union femelle BSP

Femelle BSP union cap lift check valve



Corps : Bronze
Clapet : Inox ASTM A182 F316L
Ressort : Inox 303
Étanchéité :
CS2142 Inox
CS2143 PTFE
Raccordement : Femelle BSP
Pression de service max : 25 bar
Température de service max :
-10°C/+180°C

Body: Bronze
Disc: Stainless steel ASTM A182 F316L
Spring: Stainless steel 303
Seal:
CS2142 Stainless steel
CS2143 PTFE
Connection: Female BSP
Maximum working pressure: 25 bar
Maximum working temperature:
-10°C/+180°C



Montage toutes positions grâce au ressort.
Mountable in all positions thanks to the spring.

DN		L (mm)	Kg	Ref.
mm	inch			
8	1/4"	46	0,197	CS2142-0008 CS2143-0008
10	3/8"	46	0,202	CS2142-0010 CS2143-0010
15	1/2"	56	0,281	CS2142-0015 CS2143-0015
20	3/4"	62	0,504	CS2142-0020 CS2143-0020
25	1"	74	0,727	CS2142-0025 CS2143-0025
32	1"1/4	91	1,164	CS2142-0032 CS2143-0032
40	1"1/2	100	1,504	CS2142-0040 CS2143-0040
50	2"	128	2,508	CS2142-0050 CS2143-0050

CS3240

Clapet à soupape à brides PN16

Flanged type lift check valve PN16



Corps : Fonte GG25
Obturbateur : Fonte GG25
Ressort : Inox 304
Étanchéité : Inox
Raccordement : A brides PN16
Pression de service : 16 bar
Température de service max :
+120°C (16 bar)/+225°C (12 bar)

Body: Cast Iron GG25
Disc: Cast iron GG25
Spring: Stainless steel 304
Seal: Stainless steel
Connection: Flanged PN16
Maximum working pressure: 16 bar
Maximum working temperature:
+120°C (16 bar)/+225°C (12 bar)



Montage toutes positions grâce au ressort
Mountable in all positions thanks to the spring

DN		L (mm)	Kg	Ref.
mm	inch			
15	1/2"	130	2,2	CS3240-0015
20	3/4"	150	3,3	CS3240-0020
25	1"	160	3,8	CS3240-0025
32	1"1/4	180	5,5	CS3240-0032
40	1"1/4	200	6,9	CS3240-0040
50	2"	230	8,7	CS3240-0050
65	2" 1/2	290	15	CS3240-0065
80	3"	310	20	CS3240-0080
100	4"	350	25	CS3240-0100
125	5"	400	40	CS3240-0125
150	6"	480	55	CS3240-0150
200	8"	600	88	CS3240-0200
250	10"	730	196	CS3240-0250
300	12"	850	300	CS3240-0300

CS5261S1

Clapet à soupape à brides PN40

Flanged type lift check valve PN40



Corps : Acier GP240GH
Chapeau : Acier GP240GH
Obturbateur : Inox 304
Joint : Graphite
Raccordement : A brides PN40
Pression de service max : 40 bar
Température de service max : 180°C

Body: Steel GP240GH
Bonnet: Steel GP240GH
Disc: Stainless steel 304
Gasket: Graphite
Connection: Flanged PN40
Maximum working pressure: 40 bar
Maximum working temperature: 180°C



Montage toutes positions grâce au ressort
Mountable in all positions thanks to the spring

DN		L (mm)	Kg	Ref.
mm	inch			
25	1"	160	4,5	CS5261S1-0025
32	1"1/4	180	5,5	CS5261S1-0032
40	1"1/4	200	9	CS5261S1-0040
50	2"	230	11	CS5261S1-0050
65	2" 1/2	290	15	CS5261S1-0065
80	3"	310	24	CS5261S1-0080
100	4"	350	32	CS5261S1-0100
125	5"	400	48	CS5261S1-0125
150	6"	480	65	CS5261S1-0150





CLAPETS D'EXTREMITÉ
TERMINAL CHECK VALVES



**Empêche le retour des eaux dans la conduite.
Prevents water backflow in the pipe.**

CBT6206 | CBT6209A

Clapet d'extrémité acier inoxydable
Stainless steel terminal check valve



Corps : Acier inoxydable 304
Battant : Acier inoxydable 304
Étanchéité : EPDM
Raccordement :
DN200-500 : à brides PN10
DN600-2000 : à brides PN2,5
Pression de service max : 0,5 bar
Température de service max : 120°C

Body: Stainless steel 304
Disc: Stainless steel 304
Seal: EPDM
Connection:
DN200-500: flanged PN10
DN600-2000: flanged PN2,5
Maximum working pressure: 0,5 bar
Maximum working temperature: 120°C



**Étanchéité optimale
Optimal sealing**

DN			L (mm)	Acier inoxydable 304 Stainless steel 304	Acier inoxydable 316 Stainless steel 316
mm	inch	Ref.		Ref.	
200	8"	340		CBT6206-0200	CBT6209A-0200
300	12"	440		CBT6206-0300	CBT6209A-0300
400	16"	540		CBT6206-0400	CBT6209A-0400
500	20"	640		CBT6206-0500	CBT6209A-0500
600	24"	740		CBT6206-0600	CBT6209A-0600
700	28"	840		CBT6206-0700	CBT6209A-0700
800	32"	940		CBT6206-0800	CBT6209A-0800
900	36"	1040		CBT6206-0900	CBT6209A-0900
1000	40"	1140		CBT6206-1000	CBT6209A-1000
1100	44"	*		CBT6206-1100	CBT6209A-1100
1200	48"	*		CBT6206-1200	CBT6209A-1200
1300	50"	*		CBT6206-1300	CBT6209A-1300
1400	56"	*		CBT6206-1400	CBT6209A-1400
1500	60"	*		CBT6206-1500	CBT6209A-1500
1600	64"	*		CBT6206-1600	CBT6209A-1600
1700	66"	*		CBT6206-1700	CBT6209A-1700
1800	72"	*		CBT6206-1800	CBT6209A-1800
2000	80"	*		CBT6206-2000	CBT6209A-2000

* sur demande / on request

CBT9200

Clapet d'extrémité polyamide
Terminal check valve polyamide



Corps + battant : Polyamide renforcé à 20% de fibres de verre recyclable
Ancrages mécaniques : Inox AISI 316
Joints (battants + corps) : EPDM
Raccordement : Brides ISO PN10
Tenue à la pression : 1 bar (10 mCE)
Température de service max : 70°C
Se fixe:
- sur toute paroi béton verticale à l'aide de 4 ancrages mécaniques fournis.
- sur bride de canalisation PN10 (visserie non fournie).

Body + disc: 20% Glass fiber reinforced polyamide recyclable
Shaft: Stainless Steel AISI 316
Seals: EPDM
Connection: Flanged ISO PN10
Maximum working pressure: 1 bar (10 mCE)
Maximum working temperature: 70°C
Setting:
- mounts on all types of vertical concrete walls with the 4 included mechanical anchors.
- mounts on pipe flanges PN10 (screws not included).



**Étanchéité optimale grâce à son joint mousse (contre la paroi) et son joint à lèvres.
Optimal sealing thanks to its foam gasket (against the wall) and its seal.**

DN		L (mm)	Kg	Ref.
mm	inch			
100	4"	45	0,4	CBT9200-0100
150	6"	55	0,6	CBT9200-0150
200	8"	65	0,9	CBT9200-0200

CBT9200A

Clapet d'extrémité polyester
Terminal check valve polyester



Corps + battant : Résine polyester renforcée de fibre de verre
Ancrages mécaniques : Inox AISI 316
Joints : EPDM
Raccordement : Brides ISO PN10 (à percer)
Pression max de service : 1 bar
Tenue à la pression : 1 bar (10 mCE)
Température de service max : 70°C
Se fixe:
- sur toute paroi verticale (chevilles à frapper Inox 316 fournis).
- sur bride normalisée (visserie non fournie, perçage en option surcôté).

Body + disc: Reinforced polyester resin with glassfiber
Shaft: Stainless steel AISI 316
Seals: EPDM
Connection: Flanged ISO PN10 (to drill)
Maximum service pressure: 1 bar
Pressure resistance: 1 bar (10 mCE)
Maximum working temperature: 70°C
- on vertical concrete walls (screws 316 included).
- on standardized flange (screws not included, extra cost for drilling).

DN		L (mm)	Kg	Ref.
mm	inch			
200	4"	150	1,6	CBT9200A-0200
250	10"	160	2	CBT9200A-0250
300	12"	189	3,7	CBT9200A-0300
400	16"	206	6,5	CBT9200A-0400
500	20"	240	9,7	CBT9200A-0500
600	24"	280	14,3	CBT9200A-0600
800	32"	525	25	CBT9200A-0800
1000	40"	535	102	CBT9200A-1000
1200*	48"	695	151	CBT9200A-1200
1400*	56"	800	236	CBT9200A-1400
1500*	60"	870	285	CBT9200A-1500

* Le perçage pour fixation sur bride ISO PN10 n'est pas réalisable pour les DN1200 / 1400 / 1500.

Drilling for mounting on ISO PN10 flange is not possible for DN1200/1400/1500.



**Protection contre les refoulements.
Léger et résistant (corrosion, UV, eau de mer ...).
Prevents water backflow.
Lightweight and resistant (to corrosion, UV, seawater, etc.).**





CLAPETS À PAPILLON TILTING CHECK VALVES

CP4243 | CP4243A

Clapet à papillon à brides à contrepoids
Tilting type check valve with counterweight



Corps : Fonte ductile EN-GJS-500-7 (GGG50)
Obturateur : Fonte ductile EN-GJS-500-7 (GGG50)
Siège : Inox 304
Etanchéité : EPDM
Raccordement : À brides PN10/16
Pression de service : 16 bar
Température de service : -10°C / +80°C

Body: Ductile iron EN-GJS-500-7 (GGG50)
Disc: Ductile iron EN-GJS-500-7 (GGG50)
Seat: Stainless Steel 304
Seal: EPDM
Connection: Flanged PN10/16
Working pressure: 16 bar
Working temperature: -10°C / +80°C



PN25-40 sur demande
PN25-40 on request



Inversion possible du contre-poids
Possible to reverse of the counterweight

				Clapet et contrepoids Valve with counterweight	Avec capot protection With protection guard*
DN		L (mm)	Kg	Ref.	Ref.
mm	inch				
200	8"	230	45	CP4243-0200	CP4243A-0200
250	10"	250	76	CP4243-0250	CP4243A-0250
300	12"	270	102	CP4243-0300	CP4243A-0300
350	14"	290	140	CP4243-0350	CP4243A-0350
400	16"	310	176	CP4243-0400	CP4243A-0400
450	18"	330	245	CP4243-0450	CP4243A-0450
500	20"	350	300	CP4243-0500	CP4243A-0500
600	24"	390	432	CP4243-0600	CP4243A-0600
700	28"	430	565	CP4243-0700	CP4243A-0700
800	32"	470	833	CP4243-0800	CP4243A-0800
900	36"	510	1081	CP4243-0900	CP4243A-0900
1000	40"	550	1268	CP4243-1000	CP4243A-1000
1200	48"	630	2127	CP4243-1200	CP4243A-1200

NEW

***CP4243A**

Prix de la vanne complète avec capot de protection Inox 304 inclus pour plus de sécurité.
Price of valve complete with stainless steel 304 protective cover for better safety.



CP4208 | CP4248

Clapet à papillon à brides à contrepoids avec amortisseur hydraulique
Tilting type check valve with counterweight and hydraulic damper



Corps et papillon : Fonte ductile GGG50
Siège : Acier inoxydable 304
Axe de manoeuvre : Acier inoxydable 420
Joint : EPDM
Raccordement : À brides PN10 ou PN16
Température de service : -10°C / +80°C
Avec levier, contrepoids et vérin hydraulique

Body and Disc: Ductile iron GGG50
Seat: Stainless steel 304
Shaft: Stainless steel 320
Sealing ring: EPDM
Connection: Flanged PN10 or PN16
Working temperature: -10°C / +80°C
With lever, counterweight and hydraulic damper

NEW

				PN10	PN16
DN		L (mm)	Kg	Ref.	Ref.
mm	inch				
350	14"	290	225	CP4208-0350	CP4248-0350
400	16"	310	270	CP4208-0400	CP4248-0400
450	18"	330	324	CP4208-0450	CP4248-0450
500	20"	350	385	CP4208-0500	CP4248-0500
600	24"	390	513	CP4208-0600	CP4248-0600
700	28"	430	678	CP4208-0700	CP4248-0700
800	32"	470	891	CP4208-0800	CP4248-0800
900	36"	510	1243	CP4208-0900	CP4248-0900
1000	40"	550	1586	CP4208-1000	CP4248-1000
1200	48"	630	2623	CP4208-1200	CP4248-1200



Avec levier contrepoids et vérin hydraulique - amortissement sur la fermeture.
With lever, counterweight and hydraulic damper - damping during closure.



Prévoir de rajouter de l'huile hydraulique pour le vérin (type YB-N46 ou similaire).
Add Hydraulic oil (type YB-N46 or equivalent).



Contactez-nous pour toute demande de position verticale; nous préciser la position du clapet lors de votre demande (position livrée en horizontal en standard) ainsi que l'environnement amont/aval du clapet pour vous préconiser l'équipement le plus adapté.

Contact us for any vertical position requests: please specify the position of the check valve (position delivered horizontally as standard) as well as the upstream / downstream environment of the check valve to recommend the most suitable equipment.





DISCONNECTEURS BACKFLOW PREVENTERS



Le disconnecteur prévient tout dysfonctionnement du réseau et garantit une excellente qualité de l'eau. En cas de changement de pression, il permet un arrêt automatique de la distribution d'eau.

The polluted fluid is isolated puis rejeté hors du réseau d'eau.

The backflow preventer warns of any dysfunction in the network and guarantees excellent water quality.

In case of a reversal in pressure, it automatically stops the distribution of water. The polluted fluid is isolated then disposed into the network of water to discharge.

X2101

Disconnecteur femelle BSP - à zone de pression différente non contrôlable (type CA 573)

Female BSP backflow preventer - non-controllable different pressure area - CA 573 type



Corps et siège : Laiton
Obturbateur : POM
Joint et membrane : NBR
Raccordement : Femelle BSP
Pression de service max : 10 bar
Température de service : +5°C/+65 °C

Body & Seat: Brass
Disc: POM
Gasket & membrane: NBR
Connection: Female BSP
Maximum working pressure: 10 bar
Working temperature: +5°C/+65 °C

DN		L (mm)	Kg	Ref.
mm	inch			
15	1/2"	121	0,59	X2101-0015
20	3/4"	151	0,66	X2101-0020

ACS

X2102

Disconnecteur type "BA" mâle BSP - à zone de pression réduite contrôlable (type BA 574)

Male BSP backflow preventer "BA" type - controllable reduced pressure area - BA 574 type



Corps et chapeau :
Laiton du 1/2" au 1"1/4"
Bronze du 1"1/2" au 2"
Obturbateurs : Laiton
Axe : Inox
Membrane : EPDM
Joints : NBR
Raccordement : Mâle BSP
Pression de service max : 10 bar
Température de service : +5°C / +65 °C

Body & bonnet :
Brass from 1/2" up to 1"1/4"
Bronze from 1"1/2" up to 2"
Disc: Brass
Stem: Stainless steel
Membrane: EPDM
Gaskets: NBR
Connection: Male BSP
Maximum working pressure: 10 bar
Working temperature: +5°C/+65 °C

DN		L (mm)	Kg	Ref.
mm	inch			
15	1/2"	173	1,06	X2102-0015
20	3/4"	200	1,8	X2102-0020
25	1"	262	3,7	X2102-0025
32	1"1/4"	277	5	X2102-0032
40	1"1/2"	330	7	X2102-0040
50	2"	396	9,8	X2102-0050

ACS

X2203

Disconnecteur à brides - à zone de pression réduite contrôlable (type BA 575)

Flanged backflow preventer - controllable reduced pressure area - BA575 type



Corps et chapeau : Bronze
Obturbateurs : Laiton
Ressort : Inox
Membrane : EPDM
Joints : NBR
Raccordement : À brides PN10
Pression de service max : 10 bar
Température de service : +5°C/+65 °C

Body & bonnet: Bronze
Disc: Brass
Spring: Stainless steel
Membrane: EPDM
Gaskets: NBR
Connection: Flanged PN10
Maximum working pressure: 10 bar
Working temperature: +5°C/+65 °C

DN		L (mm)	Kg	Ref.
mm	inch			
65	2"1/2"	305	17	X2203-0065
80	3"	470	26,5	X2203-0080
100	4"	470	28	X2203-0100



CLAPETS CHECK VALVES

GÉNÉRALITÉS

Respecter le sens de montage des clapets. (Voir Fig. 36)
Respecter les correspondances de DN entre le clapet et la tuyauterie. Respecter les distances minimales d'implantation. (Voir Fig. 37)
Respecter les cycles d'utilisations, éviter les régimes pulsatoires et les utilisations anormales du clapet. (Voir Fig. 37)

LIMITES D'UTILISATION

L'utilisateur doit s'assurer de l'utilisation du matériel dans les bonnes conditions de service (Pression, température et nature du fluide) préconisées sur la documentation TECOFI et les plaques de marquage. Les températures d'utilisation des clapets, vis-à-vis du fluide, dépendent du matériau des joints de siège ou de la boule.
Se conformer au marquage de la plaque signalétique CE, qui définit les températures minimums et maximales de service (TS).

CLAPETS À BOULE

Pour DN > 250 : montage hors axe avec décalage possible afin de diminuer les coups de bélier lors de la descente de la boule. (Voir Fig. 35)
Dans le cas d'un montage horizontal, attention à l'utilisation sous faible charge (fermeture de la boule).
Étanchéité relative sur eau claire.
Sur les clapets à boule, le bouchon de dégazage permet de décoller manuellement la boule, en régime de fonctionnement.
Montage sur fluide descendant interdit. (Voir Fig. 36)

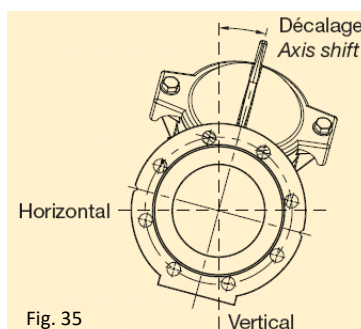

Fig. 35

- A partir de DN 300 l'inclinaison du clapet par rapport à la verticale permet de diminuer le risque de coup de bélier grâce à une descente plus lente de la boule.

- From DN300 the check valve inclination to the vertical allows decreasing the risk of water hammer thanks to a slower descent of the ball.

CLAPETS SIMPLE BATTANT

Monter le clapet en utilisant le crochet pour la préhension. Lors d'un montage horizontal, l'axe du crochet matérialise l'axe vertical de la tuyauterie. (Voir Fig. 36)

CLAPETS DOUBLE BATTANT

S'assurer du bon fonctionnement des ressorts de rappel.
DN > 150 : montage sur fluide descendant fortement déconseillé. (Voir Fig. 36)
Lors d'un montage horizontal, l'axe du clapet doit être vertical. (Voir Fig. 36)

GENERALITIES

Respect the assembly direction. (See Fig. 35)
Respect the correlation between the DN of the check valve and piping.
Respect the minimum distances of installation. (See Fig. 37)
Respect the cycles of uses. Avoid the pulsed operations and the abnormal uses of the check valve. (See Fig. 37)

TERMS OF USE

The user must follow the working conditions of the equipment (Pressure, temperature and nature of fluid) recommended on TECOFI documentation and the valve marking. The temperatures of use of the check valves, the fluid, depending on the material of the seat and the ball.
Conform to the marking of the CE nameplate, which defines the minimum and maximum temperatures of service (TS).

BALL CHECK VALVES

For DN > 250: possible assembly with axis shift in order to decrease the water hammers when ball descends. (See Fig. 35)
In the case of horizontal assembly, be careful on using under low pressure (closing of ball). Relative tightness for clear water.
On ball check valves, the vent plug makes it possible to remove manually the ball during operation.
Assembly is not possible with a downward flow. (See Fig. 36)

SANDWICH CHECK VALVE

Mount the valve using the hook.
In the case of horizontal assembly, the hook should be vertical to the piping. (See Fig. 36)

DUAL PLATE CHECK VALVE

Insure the correct operation of the return springs.
DN > 150: assembly is not possible with downward flows. (See Fig. 36)
When assembling horizontally, the axis of the check valve must be vertical. (See Fig. 36)



POSITION DES CLAPETS ET SENS DE MONTAGE

Veillez à un montage conforme au sens de la flèche.

VALVE POSITION AND ASSEMBLY

Please assemble the valve following the arrow.

Clapet à double battant / Dual plate check valve

Horizontal
Pour un montage horizontal, l'axe du clapet doit être vertical.
For horizontal assembly, the axis should be placed in the vertical position.

Vertical
Pour un montage vertical, le sens d'ouverture des battants du clapet doit correspondre à la direction du fluide.
When assembling in the vertical position, the opening direction of the plates has to be in accordance to the direction of the fluid.

Fluide descendant
Descending flow
DN < 150

Fluide ascendant
Ascending flow

Clapet à battant / swing check valve

Vertical

Fluide ascendant
Ascending flow

Fluide descendant
Descending flow

Horizontal
Pour un montage horizontal, l'axe du clapet (matérialisé par le crochet) doit être à la verticale.
For assembly in the horizontal position, ensure the axis is placed in the vertical position (ensured when hook is positioned vertically).

FIG. 36

Clapet à boule / ball check valve

Horizontal

Vertical

Fluide ascendant
Ascending flow

Fluide descendant
Descending flow

Clapet axial / Axial check valve

Montage toutes positions ; fluide ascendant ou descendant.
Mounting in all positions; ascending flow or descending flow.

Clapet à soupape / lift check valve

Montage toutes positions ; fluide ascendant ou descendant.
Mounting in all positions; ascending flow or descending flow.

ATTENTION AUX DISTANCES !

Une distance minimale doit être respectée entre le clapet et tout élément perturbateur : coude, divergent ou appareil de robinetterie.
Distance minimale :
- en amont du clapet : 6DN ;
- en aval du clapet : 2DN.

ATTENTION TO DISTANCES !

A minimum distance must be respected between the check valve and any disruptive element : elbow, reducer or any valve.
Minimum distance :
- upstream : 6DN ;
- downstream : 2DN.

DN : Diamètre Nominal / Nominal Diameter

RESPECTER LE CYCLE D'UTILISATION
Eviter les régimes pulsatoires et les utilisations anormales du clapet.

RESPECT CYCLES OF USES
Avoid the pulsed operations and abnormal uses of check valve.

FIG. 37



NOTICE D'INSTALLATION ET D'UTILISATION USE AND INSTALLATION NOTE



CLAPET/FILTRE
CHECK VALVE/ STRAINER

TABLES DES MATÉRIAUX / MATERIAL CHART

	Clapets axiaux Axial check valves			Clapets à battant Swing check valves		Clapets à soupape Lift check valves		Clapets à boule Ball check valves		Clapets à papillon Tilting check valves		Filtres Strainers	
	Corps Body	Obturateur Disc	Etanchéité Tightness	Corps et battant Body & disc	Etanchéité Tightness	Corps et chapeau Body & bonnet	Etanchéité Tightness	Corps et chapeau Body & cover	Boule Ball	Corps et battant Body & disc	Etanchéité Tightness	Corps et chapeau Body & bonnet	Tamis Screen
Fonte / Cast iron EN-GJL-250	✓	✓	✓	✓		✓						✓	
Fonte GS / Ductile iron EN-GJS-400-15	✓	✓		✓				✓		✓		✓	
Inox / Stainless steel (316)	✓	✓	✓	✓	✓		✓	✓				✓	✓
Inox / Stainless steel (304)					✓								✓
Inox X20Cr13 (inox 420)		✓	✓				✓						
Acier / Cast steel				✓		✓						✓	
Bronze				✓	✓	✓						✓	
Laiton / Brass	✓			✓	✓							✓	
PTFE			✓		✓		✓						
Nitrile			✓		✓				✓				
EPDM			✓		✓				✓		✓		
FPM (type Viton)					✓								

✓ Disponible en standard / Standard construction

Raccordement / Connection

ISO PN 10	✓		✓		✓		✓		✓		✓
ISO PN 16	✓		✓		✓		✓		✓		✓
ISO PN 20 ASA 150	✓		✓		✓						✓
ISO PN 40	✓		✓		✓				✓		✓
Taraudé gaz / Threaded BSP	✓		✓		✓		✓				✓

✓ Disponible en standard / Standard construction

Nature du fluide / Fluid type

Eau claire / Clear water	***	***	***	***	***	***	***	***	***	***	***	***
Eau chargée / Waste water			*					***		*		**
Gaz / Gas	**	**		**	**	***	***					***
Vapeur / Steam	***	***				***	***					***
Fluide agressif Corrosive fluid	***	***		***	***	***	***	**	**			***

*** Préconisé / Designed for

** Acceptable / Acceptable

* Nous consulter / On request

Position de montage / Assembly position

Descendant Descending ↓	*		*		***	***	***		*		***
Ascendant Ascending ↑	***	***	***	***	***	***	***	***	***	***	*
Horizontal ↔	***	***	***	***	***	***	***	***	***	***	***

*** Préconisé / Designed for

** Acceptable / Acceptable

* Nous consulter / On request

FOCUS : FILTRE À AIMANT

MAGNET STRAINER FOCUS

AIMANTS POUR FIXATION DES PARTICULES

Magnets to attract PARTICLES

CORPS EN FONTE
REVÊTU EPOXY 150µm
CAST IRON BODY EPOXY
COATED 150µm

TAMIS INOX 304 PERFORÉ

Maille 1 - 1,6mm
STAINLESS STEEL 304 PERFORATED
SCREEN - Mesh 1 - 1,16mm

BOUCHON DE VIDANGE
DRAIN PLUG

VISSERIE INOX
STAINLESS STEEL SCREWS

Voir page 188
See page 188

CLAPE/FILTRE
CHECK VALVE/ STRAINER

AVANTAGES

Recueille toutes les impuretés qui se trouvent dans l'installation. Élimine les particules métalliques trop fines pour être filtrées mais qui risquent de détériorer les appareils en aval du filtre.
Cela évite également la contamination du process.
Filtre les particules suivantes : fer, acier.
Installations en amont des chaudières recommandées.

ADVANTAGES

Collects all impurities in the installation. Eliminates metal particles that are too thin to be filtered, but can damage the equipment installed after the strainer.
This also prevents contamination of the process.
Filters the following particles: Iron, Steel.
Installations upstream of boilers recommended.

ENTRETIEN

Lors du nettoyage du tamis dévisser l'aimant du couvercle pour enlever les particules métalliques accrochées.

MAINTENANCE

When cleaning the screen unscrew the magnet from the filter cover to remove the collected metal particles.



FILTRES À TAMIS FONTE
CAST IRON STRAINERS

F3240S1-EP

Filtere à tamis Y fonte à brides - PN16

Y strainer cast iron flanged - PN16



Corps :

DN15-300 : Fonte EN-GJL-250 (GG25)
DN350-400 : Fonte ductile EN-GJS-500 (GGG50)

Tamis : Inox 304

DN15-50 : Maille 1 mm

DN65-150 : Maille 1,3 mm

DN200-400 : Maille 1,6 mm

Bouchon de purge : Inox 304

Boulonnerie : Inox 304

Joint : EPDM CH

Raccordement :

DN15-150 : À brides PN10/PN16

DN200-400 : À brides PN16

Pression de service : 16 bar

Température de service max :

-15°C / + 140°C

Body:

DN15-300: Cast iron EN-GJL-250 (GG25)

DN350-400: Fonte ductile EN-GJS-500

(GGG50)

Screen: Stainless steel 304

DN15-50: Mesh 1 mm

DN65-150: Mesh 1,3 mm

DN200-400: Mesh 1,6 mm

Drain plug: Stainless steel 304

Bolts: Stainless steel 304

Gasket: Heat EPDM

Connection:

DN15-150: Flanged PN10/PN16

DN200-400: Flanged PN16

Working pressure: 16 bar

Maximum working temperature:

-15°C / + 140°C

DN		L (mm)	Kg	Ref.
mm	inch			
15	1/2"	130	3	F3240S1-EP0015
20	3/4"	150	3,2	F3240S1-EP0020
25	1"	160	4	F3240S1-EP0025
32	1"1/4	180	6	F3240S1-EP0032
40	1"1/2	200	7	F3240S1-EP0040
50	2"	230	8	F3240S1-EP0050
65	2"1/2	290	12	F3240S1-EP0065
80	3"	310	14	F3240S1-EP0080
100	4"	350	18	F3240S1-EP0100
125	5"	400	28	F3240S1-EP0125
150	6"	480	40	F3240S1-EP0150
200	8"	600	70	F3240S1-EP0200
250	10"	730	130	F3240S1-EP0250
300	12"	850	170	F3240S1-EP0300
350	14"	980	240	F3240S1-EP0350
400	16"	1100	345	F3240S1-EP0400

PRODUITS ASSOCIÉS | RELATED PRODUCTS

F3240TAMISN-IN

Tamis pour filtre F3240S1

Screen for F3240S1 strainer

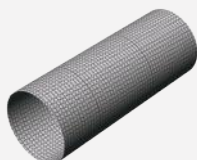

Tamis : Inox 304

DN15-50 : Maille 1 mm

DN65-150 : Maille 1,3 mm

DN200-400 : Maille 1,6 mm

Screen: Stainless steel 304

DN15-50: Mesh 1 mm

DN65-150: Mesh 1.3 mm

DN200-400: Mesh 1.6 mm

DN		Ref.
mm	inch	
15	1/2"	F3240TAMISN-IN0015
20	3/4"	F3240TAMISN-IN0020
25	1"	F3240TAMISN-IN0025
32	1"1/4	F3240TAMISN-IN0032
40	1"1/2	F3240TAMISN-IN0040
50	2"	F3240TAMISN-IN0050
65	2"1/2	F3240TAMISN-IN0065
80	3"	F3240TAMISN-IN0080
100	4"	F3240TAMISN-IN0100
125	5"	F3240TAMISN-IN0125
150	6"	F3240TAMISN-IN0150
200	8"	F3240TAMISN-IN0200
250	10"	F3240TAMISN-IN0250V2
300	12"	F3240TAMISN-IN0300V2
350	14"	F3240TAMISN-IN0350
400	16"	F3240TAMISN-IN0400

F3240JOINTN-EP

Joint de chapeau pour filtre F3240S1

Bonnet gasket for strainer F3240S1



Joint : EPDM CH

Gasket: Heat EPDM

DN		Ref.	DN		Ref.
mm	inch		mm	inch	
15	1/2"	F3240JOINTN-EP0015	100	4"	F3240JOINTN-EP0100
20	3/4"	F3240JOINTN-EP0020	125	5"	F3240JOINTN-EP0125
25	1"	F3240JOINTN-EP0025	150	6"	F3240JOINTN-EP0150
32	1"1/4	F3240JOINTN-EP0032	200	8"	F3240JOINTN-EP0200
40	1"1/2	F3240JOINTN-EP0040	250	10"	F3240JOINTN-EP0250
50	2"	F3240JOINTN-EP0050	300	12"	F3240JOINTN-EP0300
65	2"1/2	F3240JOINTN-EP0065	350	14"	F3240JOINTN-EP0350
80	3"	F3240JOINTN-EP0080	400	16"	F3240JOINTN-EP0400



F3242

ACS

Filtre à tamis fonte ACS - PN16

ACS cast iron strainer - PN16



Corps et chapeau : Fonte EN-GJL-250 (GG25)
Tamis : ASTM A182 F316
Tamis démontable maille :
 DN40-50 : 1mm
 DN65-80 : 1,25mm
 DN100-300 : 1,6 mm
Bouchon de vidange : 1/2" BSP du DN40 au DN125, 3/4" au delà du DN125
Etanchéité : EPDM
Raccordement : A brides PN16 / PN10 DN>200
Pression de service max : 16 bar DN40-200
 10 bar > DN200
Température de service max : +80°C

Body, bonnet : Cast iron EN-GJL-250 (GG25)
Screen : ASTM A182 F316
Screen mesh :
 DN40-50: 1mm
 DN65-80: 1.25mm
 DN100-300: 1.6 mm
Drain plug: 1/2" for DN40 up to DN125
 3/4" for over DN125
Seal: EPDM
Connection: Flanged PN16 / PN10 DN>200
Maximum Working pressure: 16 bar DN40-200
 10 bar > DN200
Maximum working temperature: +80°C

DN		L (mm)	Kg	Ref.
mm	inch			
40	1 1/2	200	6,3	F3242-0040
50	2"	230	7,7	F3242-0050
65	2 1/2	290	11,4	F3242-0065
80	3"	310	14,2	F3242-0080
100	4"	350	18,5	F3242-0100
125	5"	400	28,5	F3242-0125
150	6"	480	39,2	F3242-0150
200	8"	600	61,2	F3242-0200
250	10"	730	115,6	F3242-0250
300	12"	850	155,5	F3242-0300

F3230

ASA 150

Filtre à tamis «Y» fonte - ASA150

"Y" type cast iron strainer - ASA150



Corps :
 Fonte EN-GJL-250 (GG25)
Tamis : Inox 304 - Maille 1mm
Bouchon de purge : Acier A105
Joint : Graphite
Raccordement : A brides ASA 150
Pression de service : 16 bar
Température de service max :
 -10°C / + 200°C

Body:
 Cast iron EN-GJL-250 (GG25)
Screen: Stainless steel 304 - Mesh 1mm
Drain plug: Carbon steel A105
Gasket: Graphite
Connection: Flanged ASA 150
Working pressure: 16 bar
Maximum working temperature:
 -10°C / + 200°C

DN		L (mm)	Kg	Ref.
mm	inch			
50	2"	230	8	F3230-0050
65	2 1/2	290	12	F3230-0065
80	3"	310	14	F3230-0080
100	4"	350	18	F3230-0100
125	5"	400	32	F3230-0125
150	6"	480	45	F3230-0150
200	8"	600	80	F3230-0200
250	10"	730	130	F3230-0250
300	12"	850	195	F3230-0300

F3240N

Haute température | High temperature

Filtre à tamis fonte - haute température - PN16

Cast iron strainer - high temperature - PN16



Corps :
 Fonte EN-GJL-250 (DN15-300)
 Fonte EN-GJS-400 (DN350-400)
Tamis : Inox 304
Maille :
 DN15-50 : 1mm
 DN65-150 : 1,3mm
 DN200-400 : 1,6mm
Bouchon de purge : Acier A105
Joint : Graphite
Raccordement :
 DN15-150 : À brides PN10/PN16
 DN200-400 : À brides PN16
Pression de service : 16 bar
Température de service : -10°C/+200°C

Body:
 Cast iron EN-GJL-250 (DN15-300)
 Ductile iron EN-GJS-400 (DN350-400)
Screen: Stainless steel 304
Mesh:
 DN15-50: 1mm
 DN65-150: 1.3mm
 DN200-400: 1.6mm
Drain plug: Steel A105
Gasket: Graphite
Connection:
 DN15-150: Flanged PN10/PN16
 DN200-400: Flanged PN16
Working pressure: 16 bar
Working temperature: -10°C/+200°C

DN		L (mm)	Kg	Ref.
mm	inch			
15	1/2"	130	3	F3240N-0015
20	3/4"	150	3,2	F3240N-0020
25	1"	160	4	F3240N-0025
32	1 1/4	180	6	F3240N-0032
40	1 1/2	200	7	F3240N-0040
50	2"	230	8	F3240N-0050
65	2 1/2	290	12	F3240N-0065
80	3"	310	14	F3240N-0080
100	4"	350	18	F3240N-0100
125	5"	400	32	F3240N-0125
150	6"	480	45	F3240N-0150
200	8"	600	80	F3240N-0200
250	10"	730	130	F3240N-0250
300	12"	850	170	F3240N-0300
350	14"	980	240	F3240N-0350
400	16"	1100	345	F3240N-0400

F3240NA

Avec aimant | With magnet

Filtere à tamis fonte - PN16 - avec aimant
Cast iron strainer - PN16 - with magnet



Corps :
Fonte EN-GJL-250 (DN15-300)
Fonte EN-GJS-400 (DN350-400)
Tamis : Inox 304
Maille :
DN15-50 : 1mm
DN65-150 : 1,3mm
DN200-400 : 1,6mm
Joint : Graphite
Raccordement :
DN15-150 : À brides PN10/PN16
DN200-400 : À brides PN16
Pression de service : 16 bar
Température de service : -10°C/+200°C
Avec aimant

Body:
Cast iron EN-GJL-250 (DN15-300)
Ductile iron EN-GJS-400 (DN350-400)
Screen: Stainless steel 304
Mesh:
DN15-50: 1mm
DN65-150: 1.3mm
DN200-400: 1.6mm
Gasket: Graphite
Connection:
DN15-150: Flanged PN10/PN16
DN200-400: Flanged PN16
Working pressure: 16 bar
Working temperature: -10°C/+200°C
With magnet

DN		L (mm)	Kg	Ref.
mm	inch			
15	1/2"	130	3,1	F3240NA-0015
20	3/4"	150	3,3	F3240NA-0020
25	1"	160	4,1	F3240NA-0025
32	1 1/4"	180	6,1	F3240NA-0032
40	1 1/2"	200	7,1	F3240NA-0040
50	2"	230	8,1	F3240NA-0050
65	2 1/2"	290	12	F3240NA-0065
80	3"	310	14	F3240NA-0080
100	4"	350	18	F3240NA-0100
125	5"	400	32	F3240NA-0125
150	6"	480	45	F3240NA-0150
200	8"	600	80	F3240NA-0200
250	10"	730	130	F3240NA-0250
300	12"	850	170	F3240NA-0300
350	14"	980	250	F4240NA-0350
400	16"	1100	360	F4240NA-0400



Élimine les particules métalliques trop fines pour être filtrées
Eliminates metal particles that are too thin to be filtered

F4250

PN25

Filtere à tamis fonte - PN25
Ductile iron strainer - PN25



Corps : Fonte ductile GGG40
Chapeau : Fonte ductile GGG40
Tamis : Inox 304
Maille :
DN40-65 : 1,5 mm
DN80-125 : 3 mm
DN150-700 : 5 mm
Bouchon de vidange : Bronze
Boulonnerie : Acier galvanisé
Joint : EPDM
Raccordement : A brides PN25
Pression de service max : 25 bar
Température de service : -10°C/+80°C

Body: Ductile iron GGG40
Bonnet: Ductile iron GGG40
Screen: Stainless steel 304
Mesh:
DN40-65: 1.5 mm
DN80-125: 3 mm
DN150-700: 5 mm
Draining plug: Bronze
Bolts: Galvanized steel
Gasket: EPDM
Connection: Flanged PN25
Maximum working pressure: 25 bar
Working temperature: -10°C/+80°C

DN		L (mm)	Kg	Ref.
mm	inch			
40	1 1/2"	205	9	F4250-0040
50	2"	217	10	F4250-0050
65	2 1/2"	222	12	F4250-0065
80	3"	264	20	F4250-0080
100	4"	335	34	F4250-0100
125	5"	335	36	F4250-0125
150	6"	433	58	F4250-0150
200	8"	524	95	F4250-0200
250	10"	637	153	F4250-0250
300	12"	762	266	F4250-0300
350	14"	769	288	F4250-0350
400	16"	1025	590	F4250-0400
450	18"	1045	735	F4250-0450
500	20"	1140	800	F4250-0500
600	24"	-	-	F4250-0600

F4260

PN40

Filtere à tamis fonte - PN40
Ductile iron strainer - PN40



Corps : Fonte ductile GGG40
Chapeau : Fonte ductile GGG40
Tamis : Inox 304
Maille :
DN40-65 : 1,5 mm
DN80-125 : 3 mm
DN150-700 : 5 mm
Bouchon de vidange : Bronze
Boulonnerie : Acier galvanisé
Joint : EPDM
Raccordement : A brides PN40
Pression de service max : 40 bar
Température de service : -10°C/+80°C

Body: Ductile iron GGG40
Bonnet: Ductile iron GGG40
Screen: Stainless steel 304
Mesh:
DN40-65: 1.5 mm
DN80-125: 3 mm
DN150-700: 5 mm
Draining plug: Bronze
Bolts: Galvanized steel
Gasket: EPDM
Connection: Flanged PN40
Maximum working pressure: 40 bar
Working temperature: -10°C/+80°C

DN		L (mm)	Kg	Ref.
mm	inch			
40	1 1/2"	205	9	F4260-0040
50	2"	217	10	F4260-0050
65	2 1/2"	222	12	F4260-0065
80	3"	264	20	F4260-0080
100	4"	335	34	F4260-0100
125	5"	335	36	F4260-0125
150	6"	433	58	F4260-0150
200	8"	524	95	F4260-0200
250	10"	637	153	F4260-0250
300	12"	762	266	F4260-0300
350	14"	769	288	F4260-0350
400	16"	1025	590	F4260-0400
450	18"	1045	735	F4260-0450
500	20"	1140	800	F4260-0500
600	24"	-	-	F4260-0600





FILTRES À TAMIS LAITON
BRASS STRAINERS

F1142

Filtre à tamis laiton - femelle BSP - PN16
Female BSP brass strainer - PN16



Corps : Laiton
Tamis : Inox 304
Maille : 0,8 mm
Raccordement : Femelle BSP
Pression de service : 16 bar
Température de service max : -20°C / +100°C

Body: Brass
Screen: Stainless steel 304
Mesh: 0.8 mm
Connection: Female BSP
Working pressure: 16 bar
Maximum working temperature: -20°C / +100°C

JUSQU'À ÉPUISEMENT DES STOCKS
WHILE STOCKS LAST

DN		L (mm)	Kg	Ref.
mm	inch			
15	1/2"	56	0,12	F1142-0015
20	3/4"	68	0,22	F1142-0020
25	1"	77	0,33	F1142-0025
32	1"1/4	94	0,51	F1142-0032
40	1"1/2	105	0,76	F1142-0040
50	2"	125	1,35	F1142-0050

F1142A

ACS

Filtre à tamis laiton - femelle BSP - PN16 - ACS
Female BSP brass strainer - PN16 - ACS



Corps : Laiton CW617N
Tamis : Inox 304
Joint de couvercle : PTFE
Raccordement : Femelle BSP
Pression de service : 16 bar
Température de service max : -20°C / +100°C

Body: Brass CW617N
Screen: Stainless steel 304
Body gasket: PTFE
Connection: Female BSP
Working pressure: 16 bar
Maximum Working temperature: -20°C / +100°C

ACS

DN		L (mm)	Kg	Ref.
mm	inch			
15	1/2"	51,38	0,110	F1142A-0015
20	3/4"	63,37	0,165	F1142A-0020
25	1"	67,76	0,260	F1142A-0025
32	1"1/4	88,31	0,520	F1142A-0032
40	1"1/2	100,16	0,680	F1142A-0040
50	2"	120,02	1,049	F1142A-0050

F1144

ACS

Filtre à tamis laiton - femelle BSP - PN16 - ACS
Female BSP brass strainer - PN16 - ACS



Corps : Laiton
Tamis : Inox 304
Maille : 0,8 mm
Raccordement : Femelle BSP
Pression de service : 16 bar
Température de service max : +120°C

Body: Brass
Screen: Stainless steel 304
Mesh: 0.8 mm
Connection: Female BSP
Working pressure: 16 bar
Maximum Working temperature: +120°C

ACS

DN		L (mm)	Kg	Ref.
mm	inch			
10	3/8"	48	0,074	F1144-0010
15	1/2"	58	0,135	F1144-0015
20	3/4"	68	0,215	F1144-0020
25	1"	75	0,335	F1144-0025
32	1"1/4	90	0,475	F1144-0032
40	1"1/2	108	0,770	F1144-0040
50	2"	130	1,280	F1144-0050
65	2"1/2	150	2,100	F1144-0065

F2142

ACS avec robinet de purge | ACS with drain valve

Filtre à tamis laiton avec robinet de purge - femelle BSP - PN16 - ACS
Female BSP brass strainer with drain valve - PN16 - ACS



Corps : Laiton
Tamis : Inox 304
Maille : 0,85 mm
Raccordement : Femelle BSP
Pression de service : 16 bar
Vanne de rinçage : Laiton
Température de service max : +120°C

Body: Brass
Screen: Stainless steel 304
Mesh: 0.85 mm
Connection: Female BSP
Working pressure: 16 bar
Drain valve: Brass
Maximum Working temperature: +120°C

ACS

DN		L (mm)	Kg	Ref.
mm	inch			
15	1/2"	58	0,24	F2142-0015
20	3/4"	68	0,32	F2142-0020
25	1"	75	0,44	F2142-0025
32	1"1/4	90	0,545	F2142-0032
40	1"1/2	108	0,895	F2142-0040
50	2"	130	1,4	F2142-0050



FILTRES À TAMIS BRONZE
BRONZE STRAINERS

F2143

Filtre à tamis bronze - femelle BSP - PN20
Female BSP bronze strainer - PN20



Corps : Bronze
Tamis : Inox 304
Maille :
DN15-25 : 0,4 mm
DN32-50 : 0,5 mm
Raccordement : Femelle BSP
Pression de service : 20 bar
Température de service max : +120°C

Body: Bronze
Screen: Stainless steel 304
Mesh:
DN15-25: 0,4 mm
DN32-50: 0,5 mm
Connection: Female BSP
Working pressure: 20 bar
Maximum Working temperature: +120°C

JUSQU'À ÉPUISEMENT DES STOCKS
WHILE STOCKS LAST

DN		L (mm)	Kg	Ref.
mm	inch			
15	1/2"	58	0,144	F2143-0015
20	3/4"	67,5	0,21	F2143-0020
25	1"	82,5	0,325	F2143-0025
32	1"1/4	91,5	0,484	F2143-0032
40	1"1/2	106,5	0,773	F2143-0040
50	2"	126	1,350	F2143-0050

F2143W

Filtre à tamis bronze - femelle/femelle BSP - PN20 - WRAS
Female BSP bronze strainer - PN20 - WRAS



Corps : Bronze
Tamis : Inox 304
Maille :
DN15-25 : 0,3 mm
DN32-50 : 0,5 mm
Joint torique : PTFE
Raccordement : Femelle/femelle BSP
Pression de service :
20 bar (températures ≤ 120°C)
16 bar (températures > 120°C)
Température de service : -10°C / + 170°C

Body: Bronze
Screen: Stainless steel 304
Mesh:
DN15-25: 0,3 mm
DN32-50: 0,5 mm
O-ring: PTFE
Connection: Female/female BSP
Working pressure:
20 bar (temperatures ≤ 120°C)
16 bar (temperatures > 120°C)
Working temperature: -10°C / + 170°C

BIENTÔT DISPONIBLE
COMING SOON



DN		L (mm)	Kg	Ref.
mm	inch			
15	1/2"	58	0,184	F2143W-0015
20	3/4"	67,5	0,296	F2143W-0020
25	1"	82,5	0,424	F2143W-0025
32	1"1/4	91,5	0,716	F2143W-0032
40	1"1/2	106,5	0,975	F2143W-0040
50	2"	126	1,493	F2143W-0050



FILTRES À TAMIS INOX
STAINLESS STEEL STRAINERS

F6169 (BSP) | F6769 (NPT)

Filtre à tamis Y taraudé Inox
Threaded type "Y" Stainless steel strainer



F6169 DN50 - BSP



Corps : Inox 316
Tamis : Inox 316
Joint : PTFE
Raccordement taraudé :
F6169-PF : BSP
F6769-PF : NPT
Pression de service : 40 bar
Température de service max :
-25°C / + 180°C
ATEX: II 2 GD CT2 :

Body: Stainless steel 316
Screen: Stainless steel 316
Bonnet gasket: PTFE
Connection:
F6169-PF: BSP threaded
F6769-PF: NPT threaded
Working pressure: 40 bar
Maximum Working temperature:
-25°C / + 180°C
ATEX: II 2 GD CT2:

BIENTÔT DISPONIBLE
COMING SOON



DN		L (mm)	Kg	Ref.
mm	inch			
08	1/4"	64	0,2	F6169-PF0008 F6769-PF0008
10	3/8"	64	0,2	F6169-PF0010 F6769-PF0010
15	1/2"	64	0,21	F6169-PF0015 F6769-PF0015
20	3/4"	80	0,34	F6169-PF0020 F6769-PF0020
25	1"	90	0,59	F6169-PF0025 F6769-PF0025
32	1"1/4	106	0,8	F6169-PF0032 F6769-PF0032
40	1"1/2	119	1,06	F6169-PF0040 F6769-PF0040
50	2"	140	1,61	F6169-PF0050 F6769-PF0050
65	2"1/2	167	2,99	F6169-PF0065 F6769-PF0065
80	3"	198	4,74	F6169-PF0080 F6769-PF0080
100	4"	238	7,88	F6169-PF0100 F6769-PF0100

F6240

Filtre à tamis Y à brides Inox PN16
Flanged type "Y" Stainless steel strainer PN16



Corps : Inox 316
Tamis : Inox 304
Maille :
DN15-50 : 0,8 mm
DN65-80 : 1 mm
DN100-200 : 3 mm
Joint : PTFE
Raccordement :
DN15-150 : À brides PN10/PN16
DN200-400 : À brides PN16
Pression de service : 16 bar
Température de service max :
-20°C / 200°C

Body: Stainless steel 316
Screen: Stainless steel 304
Mesh:
DN15-50: 0,8 mm
DN65-80: 1 mm
DN100-200: 3 mm
Gasket: PTFE
Connection:
DN15-150: Flanged PN10/PN16
DN200-400: Flanged PN16
Working pressure: 16 bar
Maximum Working temperature:
+20°C / + 200°C

DN		L (mm)	Kg	Ref.
mm	inch			
15	1/2"	130	2	F6240-0015
20	3/4"	150	2,7	F6240-0020
25	1"	160	3,5	F6240-0025
32	1"1/4	180	5	F6240-0032
40	1"1/2	200	6,1	F6240-0040
50	2"	230	8,1	F6240-0050
65	2"1/2	290	12,3	F6240-0065
80	3"	310	15,5	F6240-0080
100	4"	350	22	F6240-0100
125	5"	400	30	F6240-0125
150	6"	480	45,1	F6240-0150
200	8"	600	77,1	F6240-0200



FILTRES À TAMIS ACIER
STEEL STRAINERS

FI5843

Filtre à tamis acier forgé
Forged carbon steel "Y" strainer



Corps, chapeau : ASTM A105 N
Tamis : Inox ASTM A240 316L
Maille : 0,8 mm
Étanchéité : Inox 316 + graphite
Pression de service max : 138 bar
Température de service max : -29°C/+425°C

Body, bonnet: ASTM A105 N
Screen: Stainless steel ASTM A240 316L
Mesh: 0.8 mm
Seal: Stainless steel 316+ graphite
Maximum Working pressure: 138 bar
Maximum working temperature: -29°C/+425°C

DN		L	Kg	BSP	SW	NPT
mm	inch			Ref.	Ref.	Ref.
8	1/4"	90	0,85	FI5843BSP-0008	FI5843SW-0008	FI5843NPT-0008
10	3/8"	90	0,78	FI5843BSP-0010	FI5843SW-0010	FI5843NPT-0010
15	1/2"	90	0,73	FI5843BSP-0015	FI5843SW-0015	FI5843NPT-0015
20	3/4"	110	1,22	FI5843BSP-0020	FI5843SW-0020	FI5843NPT-0020
25	1"	130	1,88	FI5843BSP-0025	FI5843SW-0025	FI5843NPT-0025
32	1"1/4"	160	4,75	FI5843BSP-0032	FI5843SW-0032	FI5843NPT-0032
40	1"1/2"	160	4,45	FI5843BSP-0040	FI5843SW-0040	FI5843NPT-0040
50	2"	160	6,5	FI5843BSP-0050	FI5843SW-0050	FI5843NPT-0050

F5240

Filtre à tamis acier PN25/40
Steel strainer PN25/40



Corps, chapeau : ASTM A 216 WCB
Tamis : ASTM A182 F304
Maille :
DN15-50 : 1 mm
DN65-80 : 1,25 mm
DN100-200 : 1,6 mm
Joint : Graphite
Raccordement : A brides PN25/40
DN200 PN40
Pression de service max : 40 bar
Température de service max : -20°C/+400°C

Body, bonnet: ASTM A 216 WCB
Screen: ASTM A182 F304
Mesh:
DN15-50: 1 mm
DN65-80: 1.25 mm
DN100-200: 1.6 mm
Gasket: Graphite
Connection: Flanged PN25/40
DN200 PN40
Maximum Working pressure: 40 bar
Maximum working temperature:
-20°C/+400°C

DN		L (mm)	Kg	Ref.
mm	inch			
15	1/2"	130	2,65	F5240-0015
20	3/4"	150	3,8	F5240-0020
25	1"	160	4,8	F5240-0025
32	1"1/4"	180	6,9	F5240-0032
40	1"1/2"	200	9,5	F5240-0040
50	2"	230	11,9	F5240-0050
65	2"1/2"	290	16,9	F5240-0065
80	3"	310	22,1	F5240-0080
100	4"	350	31,6	F5240-0100
125	5"	400	54	F5240-0125
150	6"	480	75	F5240-0150
200	8"	600	137	F5240-0200

FI5241

ASA 150

Filtre à tamis acier à brides - chapeau boulonné - ASA 150
Flanged steel "Y" strainer bolted bonnet - ASA 150



Corps : Acier ASTM A216 WCB
Tamis : Inox 304
Maille :
DN50 : 1 mm
DN65-300 : 1.5 mm
Joint de chapeau : Graphite + inox 304
Raccordement : A brides ASA 150 LBS
Pression de service max : 20 bar
Température de service max :
-29°C/+425°C

Body: Steel ASTM A216 WCB
Screen: Stainless steel 304
Mesh:
DN50: 1 mm
DN65-300: 1.5 mm
Bonnet gasket: Graphite + Stainless Steel 304
Connection: ASA 150 LBS Flanged
Maximum Working pressure: 20 bar
Maximum Working temperature:
-29°C/+425°C

DN		L (mm)	Kg	Ref.
mm	inch			
50	2"	203	9,7	FI5241-0050
65	2"1/2"	216	23,5	FI5241-0065
80	3"	241	28	FI5241-0080
100	4"	292	37	FI5241-0100
150	6"	406	67	FI5241-0150
200	8"	495	91	FI5241-0200
250	10"	622	135	FI5241-0250
300	12"	699	168	FI5241-0300



FILTRES À PANIER
BASKET STRAINERS



Ces filtres sont installés à l'entrée des pompes et avant les compteurs d'eau et les vannes de régulation pour les protéger des débris. Lorsque le changement du tamis est difficile avec un filtre Y, nous vous recommandons le filtre à panier. These strainers are installed between pumps and before water meters and control valves to protect them from debris. If changing the screen of a Y strainer is difficult, we recommend a basket strainer.

F4206 | F4246 | F4256 | F4266

Fonte ductile | Ductile iron

Filtre à panier fonte ductile
Strainer basket type ductile iron



Corps : Fonte ductile GGG40
Tamis : Inox 304
Maille : 5mm
Boulonnerie : Acier Inoxydable A2
Bouchon de purge : Acier Inoxydable 304
Dimension du trou de purge : 2"
Joint : Nitrile
Raccordement : À brides
Température de service : -10°C/+80°C



Body: Ductile Iron GGG40
Screen: Stainless steel 304
Mesh: 5mm
Bolts: Stainless steel A2
Drain plug: Stainless steel 304
Drain dimension: 2"
O-ring: Nitrile
Connection: Flanged
Working temperature: -10°C/+80°C



DN		L (mm)	Kg	PN10	PN16	PN25	PN40
mm	inch			Ref.	Ref.	Ref.	Ref.
100	4"	330	42	voir / see PN16	F4246-0100	F4256-0100	F4266-0100
125	5"	360	56		F4246-0125	F4256-0125	F4266-0125
150	6"	390	73		F4246-0150	F4256-0150	F4266-0150
200	8"	460	122	F4206-0200	F4246-0200	F4256-0200	F4266-0200
250	10"	530	179	F4206-0250	F4246-0250	F4256-0250	F4266-0250
300	12"	630	264	F4206-0300	F4246-0300	F4256-0300	F4266-0300
350	14"	690	305	F4206-0350	F4246-0350	F4256-0350	F4266-0350
400	16"	750	335	F4206-0400	F4246-0400	F4256-0400	F4266-0400
450	18"	810	390	F4206-0450	F4246-0450	F4256-0450	F4266-0450
500	20"	880	569	F4206-0500	F4246-0500	F4256-0500	F4266-0500
600	24"	1000	962	F4206-0600	F4246-0600	F4256-0600	F4266-0600
700	28"	1130	1460	F4206-0700	F4246-0700	F4256-0700	F4266-0700
800	32"	1250	1896	F4206-0800	F4246-0800	F4256-0800	F4266-0800
900	36"	-	-	F4206-0900	F4246-0900	F4256-0900	F4266-0900
1000	40"	1500	2040	F4206-1000	F4246-1000	F4256-1000	F4266-1000



- Grande surface de filtration
- Équipé d'une purge
- Piquage en amont et aval pour manomètre

- Large filtration surface
- Equipped with drain plug
- Holes upstream and downstream for manometers

F5206 | F5246 | F5256 | F5266

Acier Carbone | Carbon steel

Filtre à panier acier carbone
Strainer basket type carbon steel



Corps : Acier carbone mécanosoudé
Tamis : Inox 304
Maille : 5mm
Boulonnerie : Acier Inoxydable A2
Bouchon de purge : Acier Inoxydable 304
Dimension du trou de purge : 2"
Raccordement : À brides
Température de service : -10°C/+80°C



Body: Carbon steel
Screen: Stainless Steel 304
Mesh: 5mm
Bolts: Stainless Steel A2
Drain plug: Stainless steel 304
Drain dimension: 2"
Connection: Flanged
Working temperature: -10°C/+80°C



DN		L (mm)	Kg	PN10	PN16	PN25	PN40
mm	inch			Ref.	Ref.	Ref.	Ref.
1100	44"	-	-	F5206-1100	F5246-1100	F5256-1100	F5266-1100
1200	48"	1800	2690	F5206-1200	F5246-1200	F5256-1200	F5266-1200





**BOÎTES À BOUE
H-STRAINERS**

F4200

PN10

Filtre boîte à boue à brides fonte ductile PN10

Flanged ductile iron H-strainer PN10



ACS



Corps, chapeau : Fonte ductile GGG40
Grille : Inox 316
Filtration standard : 2 mm
Joint : EPDM
Raccordement : A brides PN10
Pression de service max : 10 bar
Température de service max : +80°C

Body, bonnet: Ductile iron GGG40
Filter: Stainless steel 316
Standard Mesh: 2 mm
Seal: EPDM
Connection: Flanged PN10
Maximum Working pressure: 10 bar
Maximum working temperature: +80°C



**Bouchon de purge sur le chapeau
Drain plug on the bonnet**

DN		L (mm)	Kg	Ref.
mm	inch			
200	8"	500	76	F4200-0200
250	10"	580	165	F4200-0250
300	12"	610	230	F4200-0300
350	14"	650	250	F4200-0350
400	16"	800	410	F4200-0400
450	18"	800	430	F4200-0450
500	20"	950	770	F4200-0500
600	24"	1100	850	F4200-0600

F4240

PN16

Filtre boîte à boue à brides fonte ductile PN16

Flanged ductile iron H-strainer PN16



ACS



Corps, chapeau : Fonte ductile GGG40
Grille : Inox 316
Filtration standard : 2 mm
Joint : EPDM
Raccordement :
DN80-150 : A brides PN10/PN16
A partir DN200 : A brides PN16
Pression de service max : 16 bar
Température de service max : +80°C

Body, bonnet: Ductile Iron GGG40
Filter: Stainless steel 316
Standard Mesh: 2 mm
Seal: EPDM
Connection:
DN80-150: Flanged PN10/PN16
DN200-600: Flanged PN16
Maximum Working pressure: 16 bar
Maximum working temperature: +80°C

DN		L (mm)	Kg	Ref.
mm	inch			
80	3"	300	22	F4240-0080
100	4"	300	23	F4240-0100
125	5"	400	46	F4240-0125
150	6"	400	48	F4240-0150
200	8"	500	76	F4240-0200
250	10"	580	165	F4240-0250
300	12"	610	230	F4240-0300
350	14"	650	250	F4240-0350
400	16"	800	410	F4240-0400
450	18"	800	430	F4240-0450
500	20"	950	770	F4240-0500
600	24"	1100	850	F4240-0600



**Penser à monter une vanne de sectionnement en amont.
Think about adding a block valve upstream.**



Facilité de démontage par le chapeau, idéal sur les gros DN :
- en cas de problème d'encombrement
- solution pour un nettoyage facilité
Easy disassembly with the bonnet, ideal for large DN :
- In case of a blockage problem
- A solution for easy cleaning

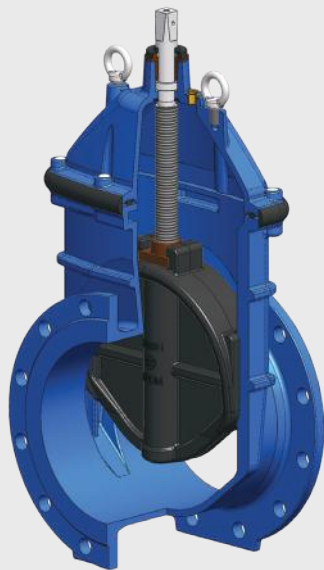

VANNE À PASSAGE DIRECT GATE VALVE

**VANNES À OPERCULE
CAOUTCHOUC
RESILIENT SEAT GATE
VALVES** [196 > 203](#)

**KIT VOC ENTERRÉES
KIT FOR BURIED
RESILIENT SEAT GATE
VALVES** [204 > 205](#)

**KIT COLONNETTE
PEDESTAL KIT**
[206 > 209](#)

**CONSEILS TECHNIQUES
TECHNICAL NOTES**
[210 > 211](#)

**VANNES À PASSAGE
DIRECT | GATE VALVES**
[212 > 214](#)

**VANNES À MANCHON
PINCH VALVES**
[214 > 215](#)

VANNE OPERCULE CAOUTCHOUC

RESILIENT SEAT GATE VALVE

EN 1074



ACS

TIGE INOX 420

420 Stainless steel stem

ANNEAUX DE LEVAGE

à partir du DN200 pour faciliter la manutention
Lifting hooks to facilitate handling from DN200

CIRE DE PROTECTION DE LA BOULONNERIE

Wax-protected bolts

PEINTURE EPOXY

cuite au four 250 microns intérieur et extérieur
250 microns interior and exterior epoxy coating

RACCORDEMENT DOUBLE PERÇAGE

PN10 et PN16 jusqu'au DN600
Double connection drilling PN10 & PN16 up to DN600

TALON D'APPUI

Heel support

TROU DANS L'AXE EXTÉRIEUR

Pour fixation rapide et directe sur les tiges de rallonge
Pin hole in spindle for quick and secure stem extension assembly

CACHE POUSSIÈRE

Dust cap

BOUCHON DE PURGE

En laiton à partir du DN300
Brass drain plug from DN300

À partir du DN300 sur vanne verticale, nous vous conseillons l'ajout du purgeur d'air automatique PU1100 (voir page 258).
From DN300 on vertical valve, we recommend adding the PU1100 automatic air trap (see page 258).



PROTECTION ELASTOMÈRE DU CORPS CONTRE LES CHOC

Elastomer protection against shock to valve body

OPERCULE EN FONTE DUCTILE

Entièrement revêtue EPDM
EPDM-lined ductile iron wedge



Résistance à la corrosion

✓ Les vannes sont revêtues de peinture époxy 250µm à l'extérieur et à l'intérieur du corps et du chapeau pour assurer une protection contre la corrosion.

Corrosion Resistance

✓ The valves are 250µm epoxy paint coated on the outside and inside of the body and the bonnet.



À partir du DN350, nous recommandons une installation de la vanne en position verticale pour son bon fonctionnement (voir page 211)
From DN350, we recommend to install the valve in upright position to get the full benefit of the resilient seat gate valve (see page 211)

VANNES OPERCULE CAOUTCHOUC

Les vannes opercules caoutchouc sont des vannes à passage direct avec une opercule revêtue d'un élastomère. Elles sont particulièrement utilisées pour les réseaux d'eaux usées, d'adduction d'eau potable, d'irrigation et d'assainissement. Son corps, chapeau et volant sont en peinture époxy.

Nos vannes opercules caoutchouc sont PN10/PN16 jusqu'au DN600 !

RESILIENT SEAT GATE VALVES

Resilient seat gate valves are gate valves with an elastomer lined wedge. They are especially used for wastewater, drinking water supply and irrigation. Body, bonnet and handwheel are epoxy coated.

OUR RESILIENT SEAT GATE VALVE ARE PN10/PN16 up to DN600!



VANNES À OPERCULE CAOUTCHOUC - SÉRIE COURTE
RESILIENT SEAT GATE VALVES - SHORT PATTERN

VOC4241C-00EP

Série courte F4 à volant | F4 short pattern with handwheel

Vanne à opercule caoutchouc F4 à volant
 F4 Resilient seat gate valve with handwheel



Corps et chapeau : Fonte ductile EN-GJS-500-7 (GGG50)
 Opercule : Fonte ductile revêtue EPDM
 Volant : Fonte ductile EN-GJS-500-7 (GGG50)
 Raccordement : Brides PN10/16
 Pression de service : 16 bar
 Température de service : +80°C
 Fermeture sens horaire
 Commande : Volant fonte ductile EN-GJS-500-7 (GGG50)
 Tige non montante

Body & bonnet: Ductile iron EN-GJS-500-7 (GGG50)
 Wedge: Ductile iron EPDM coated
 Handwheel: Ductile iron EN-GJS-500-7 (GGG50)
 Connection: Flanged PN10/16
 Working pressure: 16 bar
 Working temperature: +80°C
 Clockwise to close
 Operation: Ductile iron EN-GJS-500-7 (GGG50) handwheel
 Non-rising stem

DN50 ➔ 400 :



DN40 ➔ 400 :



Nos vannes opercule se montent entre PN10/PN16 jusqu'au DN600
Standard flange drilling PN10 / PN16 up to DN600

DN		L (mm)	Kg	Ref.
mm	inch			
40	1 1/2	140	10	VOC4241C-00EP0040
50	2"	150	10,6	VOC4241C-00EP0050
60	2 1/4	170	12,5	VOC4241C-00EP0065
65	2 1/2	180	13,8	VOC4241C-00EP0080
80	3"	180	13,8	VOC4241C-00EP0100
100	4"	190	18	VOC4241C-00EP0125
125	5"	200	22	VOC4241C-00EP0150
150	6"	210	31,9	VOC4241C-00EP0200
200	8"	230	54,5	VOC4241C-00EP0250
250	10"	250	75,5	VOC4241C-00EP0300
300	12"	270	110	VOC4241C-00EP0350
350	14"	290	158	VOC4241C-00EP0400
400	16"	310	201	VOC4241C-00EP0400

VOC4241C-08EP

Série courte F4 à réducteur | F4 short pattern with gearbox

Vanne à opercule caoutchouc F4 à réducteur
 F4 Resilient seat gate valve with gearbox



Corps et chapeau : Fonte ductile EN-GJS-500-7 (GGG50)
 Opercule : Fonte ductile revêtue EPDM
 Raccordement : Brides PN10/16
 Pression de service : 16 bar
 Température de service : +80°C
 Fermeture sens horaire
 Commande : Réducteur motorisable à volant
 Tige non montante

Body & bonnet: Ductile iron EN-GJS-500-7 (GGG50)
 Wedge: Ductile iron EPDM coated
 Connection: Flanged PN10/16
 Working pressure: 16 bar
 Working temperature: +80°C
 Clockwise to close
 Operation: Actuated gearbox with handwheel
 Non-rising stem



Nos vannes opercule se montent entre PN10/PN16 jusqu'au DN600
Standard flange drilling PN10 / PN16 up to DN600

DN		L (mm)	Kg	Ref.
mm	inch			
450	18"	330	310	VOC4241C-08EP0450
500	20"	350	400	VOC4241C-08EP0500
600	24"	390	610	VOC4241C-08EP0600

EN OPTION | OPTION

Boitier de fin de course complet | Limit switch kit :
 (300200043) p.201

VOC4241AP-08 | VOC424116AP-08

Série courte F4 à réducteur | F4 short pattern with gearbox

Vanne à opercule caoutchouc F4 à réducteur
 F4 Resilient seat gate valve with gearbox



Corps et chapeau : Fonte ductile EN-GJS-500-7 (GGG50)
 Opercule : Fonte ductile revêtue EPDM
 Raccordement : Brides PN10 ou PN16
 Pression de service : 10 bar
 Température de service : +80°C
 Fermeture sens horaire
 Commande : Réducteur motorisable à volant IP67
 Tige non montante

Body & bonnet: Ductile iron EN-GJS-500-7 (GGG50)
 Wedge: Ductile iron EPDM coated
 Connection: Flanged PN10 or PN16
 Working pressure: 10 bar
 Working temperature: +80°C
 Clockwise to close
 Operation: Actuated gearbox with handwheel IP67
 Non-rising stem

DN700 ➔ 1000 :



EN OPTION | OPTION

Boitier de fin de course complet
Limit switch kit p.201
 DN450-1000 (300200043)
 DN1200 (300200044)

DN		L (mm)	Kg	PN	Ref.
mm	inch				
700	28"	430	960	10	VOC4241AP-08EP0700
				16	VOC424116AP-08EP0700
800	32"	470	1250	10	VOC4241AP-08EP0800
				16	VOC424116AP-08EP0800
900	36"	510	1875	10	VOC4241AP-08EP0900
				16	VOC424116AP-08EP0900
1000	40"	550	3395	10	VOC4241AP-08EP1000
				16	VOC424116AP-08EP1000
1200	48"	630	4600	10	VOC4241AP-08EP1200
				16	VOC424116AP-08EP1200



Nous contacter pour tout montage sur tuyauterie verticale ou fortement inclinée. Voir conseils page 211.
Contact us for mounting on vertical or steeply inclined piping. See the technical notes page 211.

VOC4241C-051EP

Vanne à opercule caoutchouc F4 à carré
F4 Resilient seat gate valve with square cap



Corps et chapeau : Fonte ductile EN-GJS-500-7 (GGG50)
Opercule : Fonte ductile revêtue EPDM
Raccordement : Brides PN10/16
Pression de service : 16 bar
Température de service : +80°C
Fermeture sens horaire
Commande : A carré
Tige non montante

Body & bonnet: Ductile iron EN-GJS-500-7 (GGG50)
Wedge: Ductile iron EPDM coated
Connection: Flanged PN10/16
Working pressure: 16 bar
Working temperature: +80°C
Clockwise to close
Operation: Square cap
Non-rising stem

DN50 ➔ 400 :



DN40 ➔ 400 :



Vanne adaptée pour montage enterré ou sur colonnette droite et murale. Voir pages 206-207
Valve adapted for underground or column and wall installations. See pages 206-207



Série courte F4 à carré | F4 short pattern with square cap

DN		L (mm)	Kg	Ref.
mm	inch			
40	1"1/2	140	9,5	VOC4241C-051EP0040
50	2"	150	10,1	VOC4241C-051EP0050
60	2"1/4	170	12	VOC4241C-051EP0065
65	2"1/2			
80	3"	180	13,3	VOC4241C-051EP0080
100	4"	190	17,5	VOC4241C-051EP0100
125	5"	200	21,5	VOC4241C-051EP0125
150	6"	210	31,4	VOC4241C-051EP0150
200	8"	230	54	VOC4241C-051EP0200
250	10"	250	75	VOC4241C-051EP0250
300	12"	270	109,5	VOC4241C-051EP0300
350	14"	290	157,5	VOC4241C-051EP0350
400	16"	310	200,5	VOC4241C-051EP0400

Pour tout DN supérieur, nous consulter
Contact us for larger DN

VOC4241-00NI | VOC424110-00NI | VOC424116-00NI

Vanne à opercule caoutchouc F4 NBR à volant
F4 Resilient seat gate valve NBR with handwheel



Corps et chapeau : Fonte ductile EN-GJS-500-7 (GGG50)
Opercule : Fonte ductile revêtue NBR
Raccordement : A brides
DN40-150 : PN10/16
DN200-300 : PN10 ou PN16
Pression de service : 16 bar
Température de service : -10°C/+70°C
Fermeture sens horaire
Commande : Volant fonte ductile EN-GJS-500-7 (GGG50)
Tige non montante

Body & bonnet: Ductile iron EN-GJS-500-7 (GGG50)
Wedge: NBR-coated ductile iron
Connection: Flanged
DN40-150 : PN10/16
DN200-300 : PN10 or PN16
Working pressure: 16 bar
Working temperature: -10°C/+70°C
Clockwise to close
Operation: Ductile iron EN-GJS-500-7 (GGG50) handwheel
Non-rising stem

Série courte F4 NBR | NBR F4 short pattern

DN		L (mm)	Kg	PN	Ref.
mm	inch				
40	1"1/2	140	7,37	10/16	VOC4241-00NI0040
50	2"	150	8,56	10/16	VOC4241-00NI0050
65	2"1/2	170	11,30	10/16	VOC4241-00NI0065
80	3"	180	14	10/16	VOC4241-00NI0080
100	4"	190	19,90	10/16	VOC4241-00NI0100
125	5"	200	24,20	10/16	VOC4241-00NI0125
150	6"	210	31,80	10/16	VOC4241-00NI0150
200	8"	230	49,40	10/16	VOC424110-00NI0200 VOC424116-00NI0200
250	10"	250	84,70	10/16	VOC424110-00NI0250 VOC424116-00NI0250
300	12"	270	106	10/16	VOC424110-00NI0300 VOC424116-00NI0300

VOC4251C-00

Vanne à opercule caoutchouc F4 - tige non montante - PN25
Resilient seat gate valve - non-rising stem - PN25



Corps et chapeau : Fonte ductile EN-GJS-500-7 (GGG50)
Opercule : Fonte ductile GGG 50 revêtue EPDM
Raccordement : A brides PN25
Pression de service max : 25 bar
Température max : +80°C
Fermeture sens horaire
Commande : Volant fonte ductile EN-GJS-500-7 (GGG50)
Tige non montante

Body & bonnet: Ductile iron EN-GJS-500-7 (GGG50)
Wedge: EPDM coated ductile iron GGG50
Connection: Flanges PN25
Working pressure max: 25 bar
Max Working temperature: +80°C
Clockwise to close
Operation : Ductile iron EN-GJS-500-7 (GGG50) handwheel
Non-rising stem

Série courte F4 PN25 | PN25 F4 short pattern

DN		L (mm)	Kg	Ref.
mm	inch			
40	1"1/2	140	8	VOC4251C-00EP0040
50	2"	150	10	VOC4251C-00EP0050
65	2"1/2	170	12	VOC4251C-00EP0065
80	3"	180	16	VOC4251C-00EP0080
100	4"	190	22	VOC4251C-00EP0100
125	5"	200	32	VOC4251C-00EP0125
150	6"	210	41	VOC4251C-00EP0150
200	8"	230	72	VOC4251C-00EP0200
250	10"	250	101	VOC4251C-00EP0250
300	12"	270	155	VOC4251C-00EP0300

VOC4241CASA-00EP

Série courte F4 ASA 150 | ASA 150 F4 short pattern

Vanne à opercule caoutchouc F4 à volant ASA 150

F4 Resilient seat gate valve with handwheel - ASA 150



Corps et chapeau : Fonte ductile EN-GJS-500-7 (GGG50)
 Opercule : Fonte ductile revêtue EPDM
 Raccordement : A brides ASA 150LBS
 Pression de service : 16 bar
 Température de service : +80°C
 Fermeture sens horaire
 Commande : Volant fonte ductile EN-GJS-500-7 (GGG50)
 Tige non montante



Body & bonnet: Ductile iron EN-GJS-500-7 (GGG50)
 Wedge: Ductile iron EPDM coated
 Connection: Flanged ASA 150LBS
 Working pressure: 16 bar
 Working temperature: +80°C
 Clockwise to close
 Operation : Ductile iron EN-GJS-500-7 (GGG50) handwheel
 Non-rising stem

DN		L (mm)	Kg	Ref.
mm	inch			
40	1 1/2	140	10	VOC4241CASA-00EP0040
50	2"	150	10,6	VOC4241CASA-00EP0050
60	2 1/4	170	12,5	VOC4241CASA-00EP0065
65	2 1/2	170	12,5	VOC4241CASA-00EP0065
80	3"	180	13,8	VOC4241CASA-00EP0080
100	4"	190	18	VOC4241CASA-00EP0100
125	5"	200	22	VOC4241CASA-00EP0125
150	6"	210	31,9	VOC4241CASA-00EP0150
200	8"	230	54,5	VOC4241CASA-00EP0200
250	10"	250	75,5	VOC4241CASA-00EP0250
300	12"	270	110	VOC4241CASA-00EP0300
350	14"	290	158	VOC4241CASA-00EP0350
400	16"	310	201	VOC4241CASA-00EP0400

VOC4241CASA-08EP

Série courte F4 ASA 150 à réducteur | ASA 150 F4 short pattern with gearbox

Vanne à opercule caoutchouc F4 à réducteur ASA 150

F4 Resilient seat gate valve with gearbox - ASA 150



Corps et chapeau : Fonte ductile EN-GJS-500-7 (GGG50)
 Opercule : Fonte ductile revêtue EPDM
 Raccordement : A brides ASA 150LBS
 Pression de service : 16 bar
 Température de service : +80°C
 Fermeture sens horaire
 Commande : Réducteur motorisable à volant
 Tige non montante



Body & bonnet: Ductile iron EN-GJS-500-7 (GGG50)
 Wedge: Ductile iron EPDM coated
 Operation: Actuated gearbox with handwheel
 Working pressure: 16 bar
 Working temperature: +80°C
 Connection: Flanged ASA 150LBS
 Clockwise to close
 Operation: Actuated gearbox with handwheel
 Non-rising stem

DN		L (mm)	Kg	Ref.
mm	inch			
450	18"	330	310	VOC4241CASA-08EP0450
500	20"	350	400	VOC4241CASA-08EP0500
600	24"	390	610	VOC4241CASA-08EP0600

EN OPTION | OPTION

Boitier de fin de course complet
 Limit switch kit (300200043) p.201

VOC4241C2C

Série courte F4 avec contact mécanique | F4 short pattern with mechanical limit switches

Vanne à opercule caoutchouc F4 - tige non montante - avec kit de 2 contacts mécaniques - PN16
F4 Resilient seat gate valve - non-rising stem - PN16 with kit of 2 mechanical limit switches



Corps et chapeau :
Fonte ductile EN-GJS-500-7 (GGG50)
Opercule : Fonte ductile GGG 50 revêtue EPDM
Raccordement : A brides PN10/16
Pression de service max : 16 bar
Température max : +80°C
Fermeture sens horaire
Kit de 2 contacts mécaniques à galet type
XCKM 115 Schneider / Telemecanique
Position ouverture/fermeture

Body & bonnet:
Ductile iron EN-GJS-500-7 (GGG50)
Wedge: EPDM coated ductile iron GGG50
Connection: Flanges PN10/16
Working pressure max: 16 bar
Max Working temperature: +80°C
Clockwise to close
2 mechanical limit switches Schneider /
Telemecanique XCKM115 type
Open and closed position

DN		L (mm)	Kg	Ref.
mm	inch			
40	1 1/2	140	11,15	VOC4241C2C-00EP0040
50	2"	150	11,31	VOC4241C2C-00EP0050
65	2 1/2	170	13,73	VOC4241C2C-00EP0065
80	3"	180	15,73	VOC4241C2C-00EP0080
100	4"	190	18,63	VOC4241C2C-00EP0100
125	5"	200	26,54	VOC4241C2C-00EP0125
150	6"	210	51,70	VOC4241C2C-00EP0150
200	8"	230	55	VOC4241C2C-00EP0200
250	10"	250	83	VOC4241C2C-00EP0250
300	12"	270	118	VOC4241C2C-00EP0300
350	14"	290	184	VOC4241C2C-00EP0350
400	16"	310	230	VOC4241C2C-00EP0400

DN50 ➔ 400 :



DN40 ➔ 400 :



Equipé de 2 contacts mécaniques de fin de course et 1 indicateur de position
With two mechanical switches and a position indicator

VOC4241CM

Série courte F4 avec embase ISO | F4 short pattern with ISO plate

Vanne à opercule caoutchouc F4 - tige non montante - avec embase ISO pour motorisation électrique - PN16
F4 Resilient seat gate valve - non-rising stem - PN16 with ISO mounting plate for electric actuator



Corps et chapeau : Fonte ductile EN-GJS-500-7 (GGG50)
Opercule : Fonte ductile GGG50 revêtue EPDM ACS
Raccordement : A brides PN10/16 double perçage
Pression de service max : 16 bar
Température de service : +80°C
Fermeture sens horaire

Body & bonnet: Ductile iron GGG50
Wedge: ACS EPDM coated ductile iron GGG50
Connection: Flanges PN10/16
Working pressure max: 16 bar
Working temperature: +80°C
Clockwise to close

DN		L (mm)	Kg	Ref.
mm	inch			
40	1 1/2	140	11	VOC4241CM-00EP0040
50	2"	150	12	VOC4241CM-00EP0050
65	2 1/2	170	15	VOC4241CM-00EP0065
80	3"	180	18	VOC4241CM-00EP0080
100	4"	190	23	VOC4241CM-00EP0100
125	5"	200	36	VOC4241CM-00EP0125
150	6"	210	44	VOC4241CM-00EP0150
200	8"	230	68	VOC4241CM-00EP0200
250	10"	250	96	VOC4241CM-00EP0250
300	12"	270	140	VOC4241CM-00EP0300
350	14"	290	170	VOC4241CM-00EP0350
400	16"	310	222	VOC4241CM-00EP0400

DN50 ➔ 400 :



DN40 ➔ 400 :



VOC4241C-C08CEP | VOC4201C-C08CEP

Série courte F4 avec CFC | F4 short pattern with WSH

Vanne à opercule caoutchouc à brides avec kit boîtier fin de course AUMA WSH 14.2 - PN10/16
Resilient seat gate valve with AUMA WSH 14.2 limit switch device



Corps et chapeau :
Fonte ductile EN-GJS-500-7 (GGG50)
Opercule : Fonte ductile GGG50 revêtue EPDM
Raccordement : A brides PN10/16
PN16 à partir DN700
Pression de service max : 16 bar
Température max : +80°C
Fermeture sens horaire
Tige non montante
Réducteur motorisable avec bloc contacts fin de course AUMA WSH14.2 à volant
Avec une vis de purge

Body & bonnet:
Ductile iron EN-GJS-500-7 (GGG50)
Wedge: EPDM coated ductile iron GGG50
Connection: Flanges PN10/16
PN16 from DN700
Working pressure max: 16 bar
Max Working temperature: +80°C
Clockwise to close
Non rising stem
Gearbox with top flange ISO equipped with limit switch AUMA WSH14.2 with handwheel
With drain plugs



DN		L (mm)	Kg	PN10/16	
mm	inch			Ref.	Ref.
450	18"	330	326	VOC4241C-C08CEP0450	
500	20"	350	416	VOC4241C-C08CEP0500	
600	24"	390	626	VOC4241C-C08CEP0600	

DN		L (mm)	Kg	PN10	PN16
mm	inch			Ref.	Ref.
700	28"	960	976	VOC4201C-C08CEP0700	VOC4241C-C08CEP0700
800	32"	1250	1266	VOC4201C-C08CEP0800	VOC4241C-C08CEP0800
900	36"	1875	1891	VOC4201C-C08CEP0900	VOC4241C-C08CEP0900
1000	40"	3395	3411	VOC4201C-C08CEP1000	VOC4241C-C08CEP1000
1200	48"	4600	4622	VOC4201C-C08CEP1200	VOC4241C-C08CEP1200

DN450 ➔ 600 :



DN450 ➔ 1200 :



BOITIER FIN DE COURSE AUMA

Kit CFC Auma pour VOC TECOFI

AUMA limit switches KIT for TECOFI resilient seat gate valve



Composé de :
 - 2 fin de course (WSH 14.2) 1 ouverture / 1 fermeture
 . IP68
 . Platine F14
 . Résistance de chauffe
 - Vis, rondelle

Comprised of :
 - 2 limit switches (WSH 14.2) 1 open / 1 close
 . IP68
 . F14
 . Heat resistor
 - Screws, spring lock washer

DN		Kg	Ref.
mm	inch		
450-1000	18" - 40"	16	300200043
1200	48"	22	300200044



Se monte directement sur le réducteur de VOC version -08
 Mounted directly on the VOC version -08

VOC4241CM-U04 | VOC4241C-U04 Moteur électrique AUMA | AUMA electric actuator

Vanne à opercule caoutchouc avec moteur électrique AUMA - PN16

Resilient seat gate valve with AUMA electric actuator - PN16



Corps et chapeau : Fonte ductile EN-GJS-500-7 (GGG50)
Opercule : Fonte ductile GGG50 revêtue EPDM ACS
Raccordement : A brides PN10/16
Pression de service max : 16 bar jusqu'au DN600 (au-delà voir tableau)
Température de service : +80°C
Fermeture sens horaire
Moteur électrique AUMA 3 phases 400V/50Hz On/Off

Body & bonnet: Ductile iron EN-GJS-500-7 (GGG50)
Wedge: ACS EPDM coated ductile iron GGG50
Connection: Flanges PN10/16
Working pressure max: 16 bar up to DN600 (see table for larger DN)
Max Working temperature: +80°C
Clockwise to close
AUMA electric actuator 3-phase 400V/50Hz On/Off

DN50 ➔ 400 :



DN40 ➔ 600 :



DN		L (mm)	Kg	Ref.
mm	inch			
40	1 1/2	140	39	VOC4241CM-U04EP0040
50	2"	150	40	VOC4241CM-U04EP0050
65	2 1/2	170	43	VOC4241CM-U04EP0065
80	3"	180	46	VOC4241CM-U04EP0080
100	4"	190	51	VOC4241CM-U04EP0100
125	5"	200	64	VOC4241CM-U04EP0125
150	6"	210	72	VOC4241CM-U04EP0150
200	8"	230	116	VOC4241CM-U04EP0200
250	10"	250	144	VOC4241CM-U04EP0250
300	12"	270	193	VOC4241CM-U04EP0300
350	14"	290	223	VOC4241CM-U04EP0350
400	16"	310	275	VOC4241CM-U04EP0400
450	18"	330	358	VOC4241C-U04EP0450
500	20"	350	448	VOC4241C-U04EP0500
600	24"	390	658	VOC4241C-U04EP0600

DN		L (mm)	Kg	PN	Ref.
mm	inch				
700	28"	430	1008	10	VOC4241A-U04EP0700
				16	VOC424116A-U04EP0700
800	32"	470	1298	10	VOC4241A-U04EP0800
				16	VOC424116A-U04EP0800
900	36"	510	1923	10	VOC4241A-U04EP0900
				16	VOC424116A-U04EP0900
1000	40"	550	3448	10	VOC4241A-U04EP1000
				16	VOC424116A-U04EP1000
1200	48"	630	-	10	VOC4241A-U04EP1200
				16	VOC424116A-U04EP1200

U04

Kit moteur électrique AUMA | AUMA electric actuator kit

Kit motorisation Auma 3 phases 400V/50Hz On/Off

Kit Auma electric actuator 3-phase 400V/50Hz On/Off



Moteur équipé de :
 - 2 contacts fin de course
 - 1 résistance de chauffe
 - 2 limiteurs de couple
Commande manuelle de secours
Indicateur visuel de position
Protection IP68

Actuator equipped:
 - 2 limit switches
 - 1 heat resistor
 - 2 torque limit switches
Emergency handwheel
Visual position indicator
IP68 protection

DN		Moteur Actuator
mm	inch	
40-65	1 1/2 - 2 1/2	VOCMOTEELEC-SA07.61
80-150	3"-4"	VOCMOTEELEC-SA10.21
200-250	4"-10"	VOCMOTEELEC-SA14.21
300-400	5"-16"	VOCMOTEELEC-SA14.61
450	18"	SA142U04B4D32TOR90T
500	20"	
600	24"	

DN		PN	Moteur Actuator
mm	inch		
700-1000	28"-40"	10	SA142U04B4D32TOR125T
1200	48"	10	SA146U04B4D40TOR180T
700-900	28"-36"	16	SA142U04B4D32TOR125T
1000	40"	16	SA146U04B4D32TOR125T
1200	48"	16	SA146U04B4D40TOR180T

VOC4241CM-B04

Moteur électrique BERNARD CONTROLS | BERNARD CONTROLS electric actuator

Vanne à opercule caoutchouc - avec moteur électrique BERNARD CONTROLS - PN16

Resilient seat gate valve - PN16 - with BERNARD CONTROLS electric actuator



Corps et chapeau : Fonte ductile EN-GJS-500-7 (GGG50)
 Opercule : Fonte ductile GGG 50 revêtu EPDM ACS
 Raccordement : A brides PN10/16
 Pression de service max : 16 bar jusqu'au DN600 (au-delà voir tableau)
 Température de service : +80°C
 Fermeture sens horaire
 Moteur électrique triphasé 400 volts 50 Hz On/Off

Body & bonnet: Ductile iron EN-GJS-500-7 (GGG50)
 Wedge: ACS EPDM coated ductile iron GGG50
 Connection: Flanges PN10/16
 Working pressure max: 16 bar up to DN600 (see table for larger DN)
 Max Working temperature: +80°C
 Clockwise to close
 Electric actuator 3P 400 volts 50Hz On/Off



Sur demande / On request

DN		L (mm)	Kg	Ref.
mm	inch			
50	2"	150	60	VOC4241CM-B04EP0050
65	2"1/2	170	63	VOC4241CM-B04EP0065
80	3"	180	66	VOC4241CM-B04EP0080
100	4"	190	71	VOC4241CM-B04EP0100
125	5"	200	84	VOC4241CM-B04EP0125
150	6"	210	92	VOC4241CM-B04EP0150
200	8"	230	132	VOC4241CM-B04EP0200
250	10"	250	160	VOC4241CM-B04EP0250
300	12"	270	206	VOC4241CM-B04EP0300
350	14"	290	236	VOC4241CM-B04EP0350
400	16"	310	288	VOC4241CM-B04EP0400

DN		L (mm)	Kg	Ref.
mm	inch			
450	18"	330	374	VOC4241C-B04EP0450
500	20"	350	464	VOC4241C-B04EP0500
600	24"	390	674	VOC4241C-B04EP0600

DN		L (mm)	Kg	PN	Ref.
mm	inch				
700	28"	430	1024	10	VOC4241A-B04EP0700
				16	VOC424116A-B04EP0700
800	32"	470	1314	10	VOC4241A-B04EP0800
				16	VOC424116A-B04EP0800
900	36"	510	1939	10	VOC4241A-B04EP0900
				16	VOC424116A-B04EP0900
1000	40"	550	3461	10	VOC4241A-B04EP1000
				16	VOC424116A-B04EP1000
1200	48"	630	4666	10	VOC4241A-B04EP1200
				16	VOC424116A-B04EP1200

B04

Kit moteur électrique BERNARD CONTROLS | BERNARD CONTROLS actuator kit

Kit motorisation BERNARD CONTROLS TRI 400V/50Hz On/Off

Kit electric actuator BERNARD CONTROLS TRI 400V/50Hz On/Off



Moteur équipé de :
 - 4 contacts fin de course
 - 1 résistance de chauffe
 - 2 limiteurs de couple
 Commande manuelle de secours par volant
 Indicateur de position
 Protection IP68

Actuator equipped with:
 - 4 limit switches
 - 1 heat resistor
 - 2 torque limit switches
 Emergency handwheel
 Position indicator
 IP68 protection

DN		Moteur Actuator	Ref. KIT
mm	inch		
50-65	2"-2"1/2	AT6	300200289
80-150	3"-6"	AT14	300200290
200	8"	AT25	300200291
250	10"		
300	12"	AT50	300200292
350	14"		
400	16"		
450-600	18"-24"	AT25	300200345

Modèle AT6-14 gamme Switch
 Model AT6-14 range Switch

	DN		Moteur Actuator	Ref. KIT
	mm	inch		
PN10	700	28"	AT14	300210020
	800-1000	32" - 40"	AT25	300210023
	1200	48"	AT50	300210024
PN16	700-900	28" - 36"	AT25	300210023
	1000	40"	AT50	300210025
	1200	48"	AT50	300210024





VANNES À OPERCULE CAOUTCHOUC - SÉRIE LONGUE

RESILIENT SEAT GATE VALVES - LONG PATTERN

VOC4240C-00EP

Série longue F5 | F5 Long pattern

Vanne à opercule caoutchouc F5 à volant fermeture sens horaire
F5 Resilient seat gate valve with handwheel counterclockwise close



Corps et chapeau : Fonte ductile EN-GJS-500-7 (GGG50)
Opercule : Fonte ductile revêtue EPDM
Raccordement : Brides PN10/16
Pression de service : 16 bar
Température de service : +80°C
Fermeture sens horaire
Commande : Volant
Tige non montante

Body & bonnet: Ductile iron EN-GJS-500-7 (GGG50)
Wedge: Ductile iron EPDM coated
Connection: Flanged PN10/16
Working pressure: 16 bar
Working temperature: +80°C
Clockwise to close
Operation: Handwheel
Non-rising stem

DN50 ➔ 400 :



DN40 ➔ 400 :



DN		L (mm)	Kg	Ref.
mm	inch			
40	1"1/2	240	11,2	VOC4240C-00EP0040
50	2"	250	11,8	VOC4240C-00EP0050
60	2"1/4	270	14,4	VOC4240C-00EP0065
65	2"1/2			
80	3"	280	15,2	VOC4240C-00EP0080
100	4"	300	20,2	VOC4240C-00EP0100
125	5"	325	33	VOC4240C-00EP0125
150	6"	350	35	VOC4240C-00EP0150
200	8"	400	64	VOC4240C-00EP0200
250	10"	450	87	VOC4240C-00EP0250
300	12"	500	147	VOC4240C-00EP0300
350	14"	-	-	VOC4240C-00EP0350
400	16"	600	251	VOC4240C-00EP0400

VOC4240C-00AHEP

Série longue F5 | F5 Long pattern

Vanne à opercule caoutchouc F5 à volant fermeture sens anti horaire
F5 Resilient seat gate valve with handwheel anti-counterclockwise close



Corps et chapeau : Fonte ductile wEN-GJS-500-7 (GGG50)
Opercule : Fonte ductile revêtue EPDM
Raccordement : Brides PN10/16
Pression de service : 16 bar
Température de service : +80°C
Fermeture sens anti horaire
Commande : Volant
Tige non montante

Body & bonnet: Ductile iron EN-GJS-500-7 (GGG50)
Wedge: Ductile iron EPDM coated
Connection: Flanged PN10/16
Working pressure: 16 bar
Working temperature: +80°C
Anti-counterclockwise close
Operation: Handwheel
Non-rising stem



DN		L (mm)	Kg	Ref.
mm	inch			
40	1"1/2	240	11,2	VOC4240C-00AHEP0040
50	2"	250	11,8	VOC4240C-00AHEP0050
60	2"1/4	270	14,4	VOC4240C-00AHEP0065
65	2"1/2			
80	3"	280	15,2	VOC4240C-00AHEP0080
100	4"	300	20,2	VOC4240C-00AHEP0100
125	5"	325	33	VOC4240C-00AHEP0125
150	6"	350	35	VOC4240C-00AHEP0150
200	8"	400	64	VOC4240C-00AHEP0200
250	10"	450	87	VOC4240C-00AHEP0250
300	12"	500	147	VOC4240C-00AHEP0300
350	14"	-	-	VOC4240C-00AHEP0350
400	16"	600	251	VOC4240C-00AHEP0400

VOC4240C-05AHEP

Série longue F5 | F5 Long pattern

Vanne à opercule caoutchouc F5 à carré fermeture sens anti horaire
F5 Resilient seat gate valve with square cap anti-clockwise to close



Corps et chapeau : Fonte ductile EN-GJS-500-7 (GGG50)
Opercule : Fonte ductile revêtue EPDM
Raccordement : Brides PN10/16
Pression de service : 16 bar
Température de service : +80°C
Fermeture sens anti horaire
Commande : Carré de manœuvre

Body & bonnet: Ductile iron EN-GJS-500-7 (GGG50)
Wedge: Ductile iron EPDM coated
Connection: Flanged PN10/16
Working pressure: 16 bar
Working temperature: +80°C
Anti-clockwise to close
Operating: Square



DN		L (mm)	Kg	Ref.
mm	inch			
40	1"1/2	240	11	VOC4240C-05AHEP0040
50	2"	250	11,3	VOC4240C-05AHEP0050
60	2"1/4	270	19,9	VOC4240C-05AHEP0065
65	2"1/2			
80	3"	280	14,7	VOC4240C-05AHEP0080
100	4"	300	19,7	VOC4240C-05AHEP0100
125	5"	325	32,5	VOC4240C-05AHEP0125
150	6"	350	34,5	VOC4240C-05AHEP0150
200	8"	400	63,5	VOC4240C-05AHEP0200
250	10"	450	86,5	VOC4240C-05AHEP0250
300	12"	500	146,5	VOC4240C-05AHEP0300
350	14"	-	-	VOC4240C-05AHEP0350
400	16"	600	250,5	VOC4240C-05AHEP0400



KIT POUR VANNES À OPERCULE CAOUTCHOUC ENTERRÉES
KIT FOR BURIED RESILIENT SEAT GATE VALVES

VANNE PASSAGE DIRECT
GATE VALVE

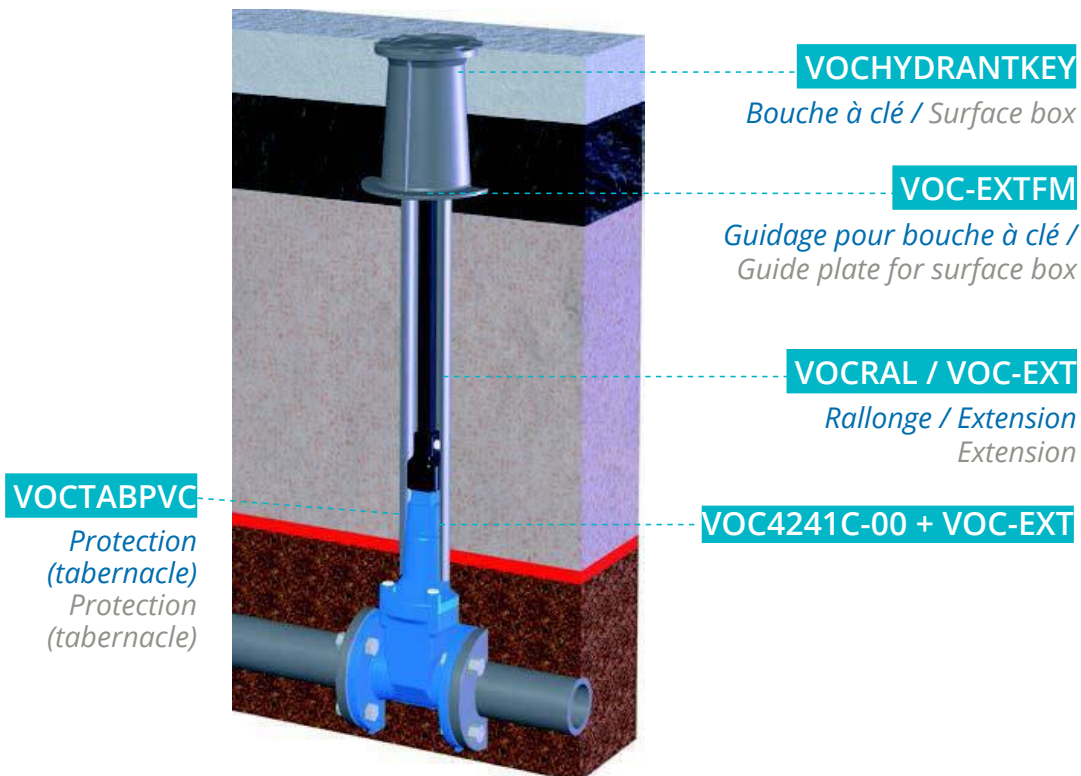

CARRÉ DE MANŒUVRE | SQUARE ADAPTOR

Carré de manœuvre pour vanne à opercule caoutchouc
Square adaptor for resilient seat gate valve



Matière DN40-400 : Fonte GG25 (30*30)
Matière DN450-600 : Inox 304
Dimensions : 30*30

Material DN40-400 : Cast iron GG25 (30*30)
Material DN450-600: Stainless Steel 304
Dimensions: 30*30

DN		Ref.
mm	inch	
40-50	1"1/2 - 2"	VOCCMC-00400050
65-80	2"1/2 - 3"	VOCCMC-00650080
100-150	4" - 6"	VOCCMC-01000150
200	8"	VOCCMC-0200
250-400	10" - 16"	VOCCMC-02500400
450-600	18" - 24"	VOCCMC-04500600



Convient pour toute la série VOC-C
Adapted for all of the VOC-C serie

RALLONGE | EXTENSION

Rallonge fixe universelle
Universal stem extension



Matière : Acier

Material: Steel

Montage avec VOC4241C-051

With VOC4241C-051

L	Ref.
1 M	VOCRAL-1.0ML
1,5 M	VOCRAL-1.5ML
2 M	VOCRAL-2.0ML
3 M	VOCRAL-3.0ML

PROTECTION | PROTECTION

Tabernacle
Tabernacle



Matière : PVC

Material: PVC

Ref.
VOCTABPVC



À utiliser avec la rallonge télescopique pour protéger la vanne enterrée
To be used with the telescopic extension to protect the buried valve



EXTENSION | EXTENSION

Extension télescopique
Telescopic extension



Matière : Acier galvanisé
Tube : Plastique
Carré : Fonte ductile

Material: Galvanised steel
Tube: Plastic
Square: Ductile iron



Equipé du tube de protection
Equipped with the protective tube

DN	L (mm)		H (mm)		Ref.
	min	max	min	max	
40-150	450	700	800	1050	VOC-EXTXS0040-0150
	650	1100	1000	1450	VOC-EXTS0040-0150
	980	1750	1330	2100	VOC-EXTM0040-0150
	1610	2900	1960	3250	VOC-EXTL0040-0150
200-400	450	700	800	1050	VOC-EXTXS0200-0400
	660	1100	1010	1450	VOC-EXTS0200-0400
	1040	1750	1390	2100	VOC-EXTM0200-0400
	1620	2900	1970	3250	VOC-EXTL0200-0400



Ajouter la dimension H du passeport technique VOC4241C-00 à la côte L pour la distance du centre de la tuyauterie à la manœuvre.

Add the dimension H from the VOC4241C-00 technical sheet to the L for the distance of the pipe axis to the actuator.

GUIDAGE | GUIDE PLATE

Plateau de centrage pour bouche à clé
Guide plate for surface box



Matière : PP

Material: PP

Ref.

VOC-EXTFM

BOUCHE A CLE | SURFACE BOX

Bouche à clé
Surface box



Construction : Fonte

Construction: Cast iron

Modèle / Model	Ref.
Rond/Round	VOHYDRANTKEY-01
Carré/Square	VOHYDRANTKEY-02

CLE DE FONTAINIER | HYDRANT KEY

Clé de fontainier universelle
Universal hydrant key

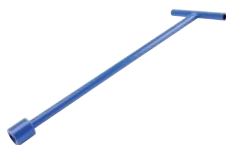

Matière : Acier
Carré : 30mm

Material: Steel
Square: 30mm



Avec embout universel pour carré de manœuvre
With universal end for operating square

L	Ref.
1M	VOCLEVWRENCH-1.0ML
1.5M	VOCLEVWRENCH-1.5ML
2M	VOCLEVWRENCH-2.0ML



KIT COLONNETTE DROITE POUR VOC*

PEDESTAL FLOOR MOUNTED KIT FOR RESILIENT SEAT GATE VALVES*

À VOLANT | WITH HANDWHEEL



VOL1 / VOL2

GUICOL

Plaque de guidage
Guide plate

COL3-F10

Colonnelle
Pedestal

U04 AUMA

F10AU1 / F14AU1

Platine pour moteur
Motor plate

COL3-F10 / COL3-F14

Colonnelle
Pedestal

EXT1/2/3/4/5

Rallonge / Extension

PAL2/3

Palier de guidage
Guide plate

ADAPTCARRÉ1

VANNE À OPERCULE
CAOUTCHOUC

Resilient seat
gate valve



Kit à utiliser avec
la vanne à opercule
caoutchouc :
VOC4241C-051
Page 198

Kit to be used with
resilient seat gate valve:
VOC4241C-051
Page 198

Représentation à titre indicatif (contre-bridés et tirants non représentés, ils sont obligatoires dans toutes installations).
Representation for reference only (counter flanges and tie rods not shown are required in all installations).

KIT COLONNETTE MURALE POUR VOC*

PEDESTAL WALL MOUNTED KIT FOR RESILIENT SEAT GATE VALVES*

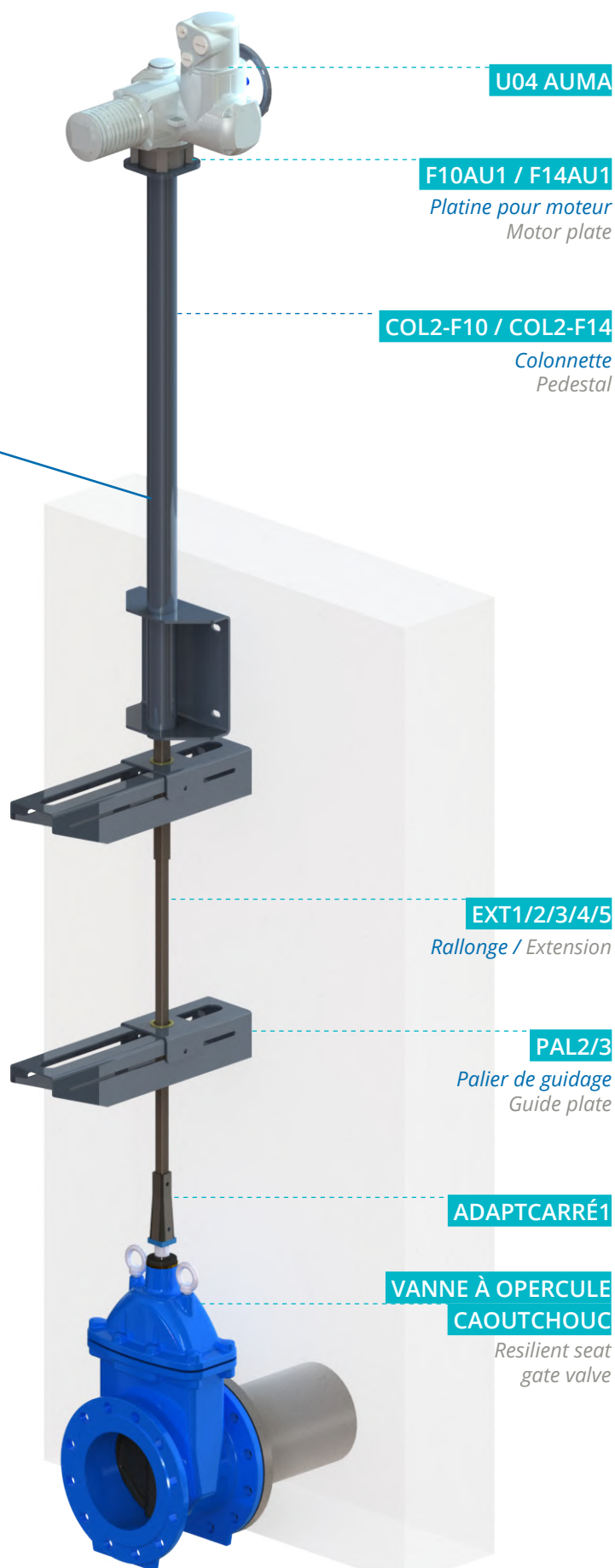
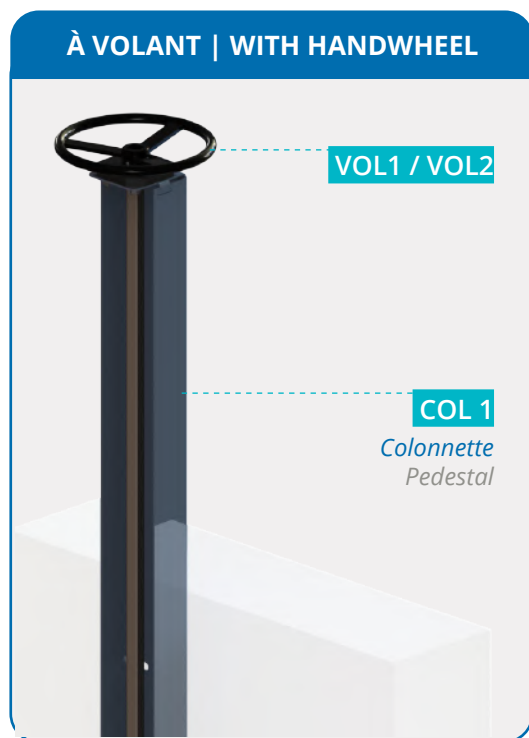

Kit à utiliser avec
la vanne à opercule
caoutchouc :
VOC4241C-051
Page 198

Kit to be used with
resilient seat gate
valves:
VOC4241C-051
Page 198



La distance entre le mur et les colonnettes murales n'est pas réglable. Prévoir un déport avec le mur ou un système pour plaquer la colonnette à la bonne distance.
The distance between the wall and the wall column is not adjustable, provide an offset with the wall or a system to place the column at the right distance.

Représentation à titre indicatif (contre-bridés et tirants non représentés, ils sont obligatoires dans toutes installations).
Representation for reference only (counter flanges and tie rods not shown are required in all installations).



TRINGLERIES POUR MONTAGE SUR COLONNETTE LINKAGE FOR PEDESTAL MOUNTED

CARRE CONIQUE I SQUARE ADAPTOR

Pour adaptation de carré conique à rallonge EXT
Square 30x30 adaptor for EXT extension



Matière : Inox 304

Material: Stainless Steel 304

Ref.

ADAPTCARRE1

RALLONGE I EXTENSION

Rallonge télescopique
Telescopic extension



Matière : 316L

Material: 316L

Dimension (mm)	Ref.
800 - 1100	EXT1
1100 - 1750	EXT2
1750 - 3000	EXT3
3000 - 5500	EXT4
4000 - 8000	EXT5

PALIER DE GUIDAGE I GUIDE PLATE

Palier de guidage fixe pour rallonge télescopique
Guide plate for telescopic extension EXT



Matière : Inox 316L

Material: Stainless Steel 316L

Dimension (mm)	Ref.
70-200	PAL2
70-500	PAL3



Mettre obligatoirement un palier tous les 2 mètres + un autre avant le passage dans la colonnette.
Place 1 guide plate every 2 meters of the extension + 1 guide plate just before the pedestal floor.

COLONNETTE I PEDESTAL

Colonne pour vannes à opercule caoutchouc
Pedestal for resilient seat gate valve

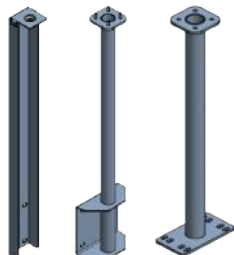

- COL1 : pour commande par volant et fixation murale
- COL2-F10 : pour commande motorisée (F10) et fixation murale
- COL2-F14 : pour commande motorisée (F14) et fixation murale
- COL3-F10 : pour commande motorisée (F10) et fixation au sol
- COL3-F14 : pour commande motorisée (F14) et fixation au sol

Matière : Inox 304
Hauteur fixe : 900mm

Pedestal wall mounted for handwheel
Pedestal wall mounted for Auma actuator (F10)
Pedestal wall mounted for Auma actuator (F14)
Pedestal floor mounted for Auma actuator (F10)
Pedestal floor mounted for Auma actuator (F14)

Material: Stainless Steel 304
Fixed height: 900mm

Ref.

COL1

COL2-F10

COL2-F14

COL3-F10

COL3-F14

1

2

3



PLAQUE DE GUIDAGE | GUIDE PLATE

Plaque de guidage pour colonnette fixation sol et commande par volant
Guide plate for pedestal floor mounted handwheel



Matière : POM

Material: POM

Ref.
GUICOL



Permet de guider la rallonge
Used to guide the extension



A utiliser obligatoirement en cas de commande par volant sur colonnette COL3-F10.
To use only with handwheel operation on pedestal COL3-F10.

VOLANT | HANDWHEEL

Volant
Handwheel



Matière : Acier revêtu Epoxy
VOL1 : Diamètre 300mm
VOL2 : Diamètre 500mm

Material: Carbon Steel Epoxy coated
VOL1: Diameter 300mm
VOL2: Diameter 500mm

DN		Ref.
mm	inch	
50-150	2"-6"	VOL1
200	8"	VOL2

PLATINE ISO POUR MOTEUR | ISO TOP FLANGE FOR ACTUATOR

Platine F10 pour moteur Auma montage sur EXT
Iso top Flange for Auma actuator

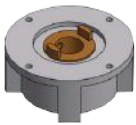

Matière : Acier
Platine : ISO5210
Pour montage sur colonnette (sur EXT)

Material: Steel
Top mounted flange: ISO5210
For assembly on column (on EXT)

Ref.	
SA07.2 SA10.2	F10AU1
SA14.2	F14AU1



Pour accouplement entre colonnette et moteur Auma
Coupling between the column and the Auma actuator

U04 - MOTEUR VOC - COLONNETTE COLONNETTE | AUMA ACTUATOR FOR VOC PEDESTAL MOUNTED

Motorisation Auma 3 phases 400V/50Hz On/Off
Auma actuator 3-phase 400V/50Hz On/Off



Moteur équipé de :
- 2 contacts fin de course
- 1 résistance de chauffe
- 2 limiteurs de couple
Commande manuelle de secours par volant
Indicateur visuel de position
Protection IP68

Actuator equipped:
- 2 limit switches
- 1 heat resistor
- 2 torque limit switches
Emergency handwheel
Visual position indicator
IP68 protection

DN		Ref.
mm	inch	
50-65	2"-2"1/2	SA07.2-U04B1TOR22
80-150	3"-6"	SA10.2-U04B1TOR32
200	8"	SA14.2-U04B1TOR32

Non recommandé au-delà du DN200, couple important.
Not recommended for size DN200 and above, high torque.



VANNES OPERCULE CAOUTCHOUC RESILIENT SEAT GATE VALVES

GÉNÉRALITÉS

Si les vannes doivent être stockées en position ouverte, une protection doit être mise en place pour protéger les vannes du sable et de la boue. Un soin tout particulier doit être pris pour protéger l'opercule et le siège.

Avant montage des vannes opercule caoutchouc, bien vérifier l'encombrement entre brides. La robinetterie n'absorbera pas les écarts. Les déformations résultant de cette pratique peuvent entraîner des problèmes d'étanchéité, des difficultés de manœuvre et même des ruptures.

Les tuyauteries doivent être parfaitement alignées et leur supportage suffisamment dimensionné afin que les vannes ne supportent aucune contrainte extérieure.

Les vannes à opercule conviennent uniquement au fonctionnement ouvert/fermé. Un fonctionnement continu en position intermédiaire entraîne une plus grande usure, il doit être évité. Il convient d'employer d'autres versions de vannes spéciales pour le service de régulation prononcé.

Lors de la fermeture des vannes, ne jamais utiliser d'outil augmentant le couple exercé sur les volants (clé à volant ou rallonge). Cette pratique risque d'endommager les portées d'étanchéité.

La vanne devra être à la pression zéro et à la température ambiante avant n'importe quelle opération de maintenance.

GENERALITIES

If the valves are to be stored in the open for sometime, protection should be provided to keep the valves clear of sand and mud. Particular care should be taken to protect the wedge and the seat.

Before assembly of resilient seat gate valves, well to verify the dimensions between flanges. The valves will not absorb the distances. The deformations resulting from this practice can entail problems of waterproofness, difficulties of operation and even breaks.

The pipings must be perfectly aligned and their sized enough support so that valves support no outside.

Resilient seat gate valves are designed to operate either in the fully closed or open positions, if used in an intermediate position this will lead to increased wear and therefore reduced.

During the closure of valve never use a tool increasing the couple exercised on steering wheels (key with steering wheel or extension lead for example). This practice risks damaging the seat.

The valve should be at zero pressure and ambient temperature prior to any maintenance.





POSITIONS RECOMMANDÉES

- 1 DN40 à DN300 :
Vanne verticale, sur tuyauterie horizontale
Vanne horizontale, sur tuyauterie horizontale
Vanne horizontale, sur tuyauterie verticale
- 2 DN350 à DN600 :
Vanne verticale, sur tuyauterie horizontale
Vanne oblique possible jusqu'à 30° maximum sur tuyauterie horizontale.
- 3 DN700 à DN1200 :
Vanne verticale exclusivement.

RECOMMENDED MOUNTING POSITIONS

- 1 DN40 to DN300 :
Valve vertical, on horizontal pipe
Valve horizontal, on horizontal pipe
Valve horizontal, on vertical pipe
- 2 DN350 to DN600 :
Valve vertical, on horizontal pipe
Valve angled up to 30° maximum from the vertical, on horizontal pipe.
- 3 DN700 to DN1200 :
Valve vertical only.

DN40 → DN300

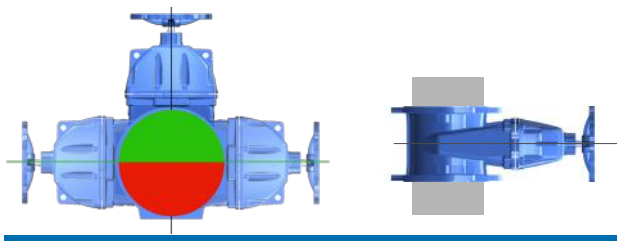

1

DN350 → DN600

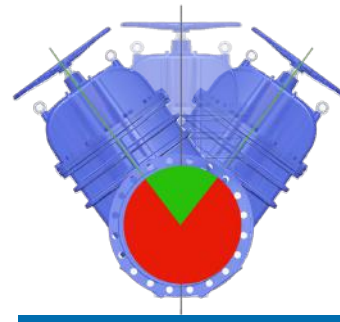

2

DN700 → DN1200



3

VANNES À PASSAGE DIRECT

GATE VALVES

V1141

Laiton PN16 | Brass PN16

Vanne à passage direct femelle BSP laiton PN16

Female BSP brass gate valve PN16



Corps : Laiton
Volant : Fonte
Chapeau : Laiton
Opercule : Laiton
Joint de tige : EPDM
Joint de chapeau : Fibre
Raccordement : Femelle BSP
Pression de service : 16 bar
Température de service : -10°C/+110°C

Body: Brass
Handwheel: Cast Iron
Bonnet: Brass
Wedge: Brass
Stem packing: EPDM
Bonnet gasket: Fiber
Connection: Female BSP
Working pressure: 16 bar
Working temperature: -10°C/+110°C

JUSQU'À ÉPUISEMENT DES STOCKS
WHILE STOCKS LAST

DN		L (mm)	Kg	Ref.
mm	inch			
15	1/2"	43,5	0,25	V1141-0015
20	3/4"	47	0,32	V1141-0020
25	1"	52	0,44	V1141-0025
32	1"1/4	63	0,73	V1141-0032
40	1"1/2	66	0,98	V1141-0040
50	2"	71	1,43	V1141-0050

V1142A

Laiton PN16 | Brass PN16

Vanne à passage direct femelle BSP laiton PN16

Female BSP brass gate valve PN16



Corps : Laiton
Volant : Fonte
Chapeau : Laiton
Opercule : Laiton
Joint de tige : PTFE
Joint de chapeau : PTFE
Raccordement : Femelle BSP
Pression de service : 16 bar
Température de service : -10°C/+80°C

Body: Brass
Handwheel: Cast Iron
Bonnet: Brass
Wedge: Brass
Stem packing: PTFE
Bonnet gasket: PTFE
Connection: Female BSP
Working pressure: 16 bar
Working temperature: -10°C/+80°C

NEW

DN		L (mm)	Kg	Ref.
mm	inch			
10	3/8"	41	0,18	V1142A-0010
15	1/2"	43	0,22	V1142A-0015
20	3/4"	44	0,29	V1142A-0020
25	1"	48	0,36	V1142A-0025
32	1"1/4	50	0,61	V1142A-0032
40	1"1/2	54,5	0,73	V1142A-0040
50	2"	61	1,10	V1142A-0050
65	2"1/2	62,5	1,95	V1142A-0065
80	3"	73	2,60	V1142A-0080
100	4"	78	4,60	V1142A-0100

V2143

Bronze PN20 | Bronze PN20

Vanne à passage direct femelle BSP bronze PN20

Female BSP bronze gate valve PN20



Corps : Bronze
Volant : Fonte
Chapeau : Bronze
Opercule : Laiton
Joint de tige : EPDM
Joint de chapeau : Fibre
Raccordement : Femelle BSP
Pression de service : 20 bar
Température de service : -10°C/+100°C

Body: Bronze
Handwheel: Cast Iron
Bonnet: Bronze
Wedge: Brass
Stem packing: EPDM
Bonnet gasket: Fiber
Connection: Female BSP
Working pressure: 20 bar
Working temperature: -10°C/+100°C

JUSQU'À ÉPUISEMENT DES STOCKS
WHILE STOCKS LAST

DN		L (mm)	Kg	Ref.
mm	inch			
15	1/2"	42	0,26	V2143-0015
20	3/4"	50	0,38	V2143-0020
25	1"	52	0,55	V2143-0025
32	1"1/4	55	0,75	V2143-0032
40	1"1/2	59	0,99	V2143-0040
50	2"	71	1,51	V2143-0050
65	2" 1/2	81	2,62	V2143-0065
80	3"	98	3,76	V2143-0080
100	4"	121	3,95	V2143-0100

V2143W

Bronze PN20 | Bronze PN20

Vanne à passage direct femelle BSP bronze PN20

Female BSP bronze gate valve PN20



Corps : Bronze
Volant :
1/2" - 2" : Aluminium
2"1/2 - 4" : Fonte
Chapeau : Bronze
Opercule : Bronze
Joint de tige : Laiton
Joint : PTFE
Raccordement : Femelle BSP
Pression de service : 20 bar
Température de service : -10°C/+170°C

Body: Bronze
Handwheel:
1/2" - 2": Aluminium
2"1/2 - 4": Cast Iron
Bonnet: Bronze
Wedge: Bronze
Stem packing: Brass
Gasket: PTFE
Connection: Female BSP
Working pressure: 20 bar
Working temperature: -10°C/+170°C

NEW

DN		L (mm)	Kg	Ref.
mm	inch			
15	1/2"	43	0,25	V2143W-0015
20	3/4"	49	0,35	V2143W-0020
25	1"	54	0,52	V2143W-0025
32	1"1/4	62	0,77	V2143W-0032
40	1"1/2	65	1,06	V2143W-0040
50	2"	75	1,61	V2143W-0050
65	2"1/2	87	2,97	V2143W-0065
80	3"	105	4,78	V2143W-0080
100	4"	124	8,61	V2143W-0100

DN15 ➔ 50 :



V6140

Inox PN16 | Stainless Steel

Vanne à opercule femelle BSP inox PN16
Female BSP Stainless steel gate valve PN16



Corps : ASTM A351 CF8M
Volant : Zamak
Opercule : ASTM A351 CF8M
Joints de corps et de presse étoupe : PTFE
Raccordement : Femelle BSP
Pression de service : 16 bar
Température de service : -20°C/+180°C

Body: ASTM A351 CF8M
Handwheel: Zamak
Gate: ASTM A351 CF8M
Packing & gasket: PTFE
Connection: Female BSP
Working pressure: 16 bar
Working temperature: -20°C/+180°C

DN		L (mm)	Kg	Ref.
mm	inch			
15	1/2"	55	0,44	V6140-0015
20	3/4"	60,5	0,57	V6140-0020
25	1"	65,5	0,74	V6140-0025
32	1 1/4"	76,5	1,12	V6140-0032
40	1 1/2"	85,5	1,55	V6140-0040
50	2"	95,5	2,25	V6140-0050

V3200

F4 PN10 (EN558-1 Serie 14) / DIN 3202 F4

Vanne à passage direct F4 tige non montante PN10
F4 Non-rising stem gate valve PN10



Corps : Fonte GG25
Obturbateur : Fonte ductile GGG40
Raccordement : A brides PN10
Etanchéité : Alliage cuivreux
Pression de service max :
DN 40 - 300 : 10 bar
DN 350 - 400 : 4 bar
Température de service max : +120°C

Body: Cast Iron GG25
Wedge: Ductile iron GGG40
Connection: Flanged PN10
Seal: Copper alloy
Maximum working pressure:
DN 40 - 300 : 10 bar
DN 350 - 400 : 4 bar
Maximum Working temperature: +120°C

DN		L (mm)	Kg	Ref.
mm	inch			
40	1 1/2"	140	8,7	V3200-0040
50	2"	150	10,8	V3200-0050
65	2 1/2"	170	12,8	V3200-0065
80	3"	180	16,6	V3200-0080
100	4"	190	22,8	V3200-0100
125	5"	200	32,1	V3200-0125
150	6"	210	42,9	V3200-0150
200	8"	230	71,3	V3200-0200
250	10"	250	98	V3200-0250
300	12"	270	145,2	V3200-0300
350	14"	290	211	V3200-0350
400	16"	310	275	V3200-0400

V4246

F4 PN16 (EN558-1 Serie 14) / DIN 3202 F4

Vanne à passage direct F4 tige non montante PN16
Non-rising stem gate valve F4 PN16



Corps : Fonte Ductile GGG50
Obturbateur : Fonte Ductile GGG50
Raccordement : A brides PN16
Etanchéité : Alliage cuivreux
Pression de service max : 16 bar
Température de service max : +120°C

Body: Ductile iron GGG50
Wedge: Ductile iron GGG50
Connection: Flanged PN16
Seal: Copper alloy
Maximum Working pressure: 16 bar
Maximum working temperature: +120°C

DN		L (mm)	Kg	Ref.
mm	inch			
40	1 1/2"	140	8,7	V4246-0040
50	2"	150	10,8	V4246-0050
65	2 1/2"	170	12,8	V4246-0065
80	3"	180	16,6	V4246-0080
100	4"	190	22,8	V4246-0100
125	5"	200	32,1	V4246-0125
150	6"	210	42,9	V4246-0150
200	8"	230	71,3	V4246-0200
250	10"	250	98	V4246-0250
300	12"	270	145,2	V4246-0300

V4242

F4 Tige montante PN16 | Rising stem PN16 (EN558-1 Serie 14) / DIN 3202 F4

Vanne à passage direct tige montante PN16
Rising stem gate valve PN16



Corps : Fonte Ductile EN-GJS-500-7
Opercule : Fonte Ductile EN-GJS-500-7
Raccordement : A brides PN16
Presse étoupe : Graphite
Siège : Alliage cuivreux
Pression de service : 16 bar
Température de service max : +180°C

Body: Ductile iron EN-GJS-500-7
Gate: Ductile iron EN-GJS-500-7
Connection: Flanged PN16
Packing: Graphite
Seat: Cast brass
Working pressure: 16 bar
Max. Working temperature: +180°C

DN		L (mm)	Kg	Ref.
mm	inch			
40	1 1/2"	140	9,8	V4242-0040
50	2"	150	11,9	V4242-0050
65	2 1/2"	170	13,3	V4242-0065
80	3"	180	17,2	V4242-0080
100	4"	190	23,2	V4242-0100
125	5"	200	34,2	V4242-0125
150	6"	210	44,4	V4242-0150
200	8"	230	67,5	V4242-0200
250	10"	250	110	V4242-0250
300	12"	270	155	V4242-0300

V4250 | V4260

F5 PN25 / PN40 (EN558-1 Serie 15) / DIN 3202 F5

Vanne à passage direct F5 tige non montante

F5 Non-rising stem gate valve



Corps : Fonte GGG40
 Volant : Fonte
 Obturateur : Fonte GGG40
 Tige : Inox 420
 Etanchéité : Bronze
 Raccordement : A brides
 Température de service max : -10°C/+80°C

Body: Ductile iron GGG40
 Handwheel: Cast Iron
 Wedge: Ductile iron GGG40
 Stem: Stainless steel 420
 Tightness: Bronze
 Connection: Flanged
 Working temperature: -10°C/+80°C

DN			PN25		PN40	
mm	inch	L (mm)	Kg	Ref.	Kg	Ref.
40	1 1/2	240	15	V4250-0040	15	V4260-0040
50	2"	250	15	V4250-0050	15	V4260-0050
65	2 1/2	270	21	V4250-0065	21	V4260-0065
80	3"	280	21	V4250-0080	21	V4260-0080
100	4"	300	31	V4250-0100	32	V4260-0100
125	5"	325	51	V4250-0125	51	V4260-0125
150	6"	350	62	V4250-0150	65	V4260-0150
200	8"	400	100	V4250-0200	116	V4260-0200
250	10"	450	155	V4250-0250	192	V4260-0250
300	12"	500	221	V4250-0300	280	V4260-0300
350	14"	550	324	V4250-0350	324	V4260-0350
400	16"	600	440	V4250-0400	480	V4260-0400
450	18"	650	575	V4250-0450	575	V4260-0450
500	20"	700	760	V4250-0500	760	V4260-0500
600	24"	800	1180	V4250-0600	1180	V4260-0600
700	28"	900	1600	V4250-0700	1600	V4260-0700
800	32"	1000	2337	V4250-0800	2337	V4260-0800



VANNES À MANCHON
PINCH VALVES

VM3200

Vanne à manchon à brides à volant PN10

Flanged pinch valve with handwheel PN10



Corps : Fonte d'aluminium
 Manchon : Gomme naturelle anti-abrasion, autres sur demande
 Raccordement : A brides PN10
 Pression de service : 3 à 4 bar
 Température de service max : +80°C

Body: Cast aluminium
 Sleeve: Natural rubber, other material on request
 Connection: Flanged PN10
 Working pressure: 3 to 4 bar
 Max Working temperature: +80°C

DN		L (mm)	Kg	Ref.
mm	inch			
15	1/2"	80	1,5	VM3200-00CN0015
20	3/4"	95	3	VM3200-00CN0020
25	1"	106	3,6	VM3200-00CN0025
32	1"	115	5,6	VM3200-00CN0032
40	1 1/2	140	8	VM3200-00CN0040
50	2"	160	10,3	VM3200-00CN0050
65	2 1/2	190	15	VM3200-00CN0065
80	3"	196	18	VM3200-00CN0080
100	4"	260	28	VM3200-00CN0100
125	5"	280	40	VM3200-00CN0125
150	6"	300	51	VM3200-00CN0150
200	8"	350	72	VM3200-00CN0200



Commande pneumatique double ou simple effet en option.
Single or double-acting pneumatic actuator optional.



Idéal pour boues, matériaux granulaires, poudres, pâtes.
Manchon interchangeable sans outil spécifique. Faibles pertes de charge.
Used for slurries, granular materials, powders, pastes.
Replaceable sleeve without any special tools. Low head losses.



VM8201-07

Vanne à manchon à brides à vérin pneumatique simple effet PN10
Flanged pinch valve with single acting pneumatic actuator PN10



Corps : Fonte d'aluminium
Manchon : Gomme naturelle anti-abrasion, autres sur demande
Raccordement : A brides PN10
Commande par vérin pneumatique simple effet avec commande manuelle de secours
Pression de service : 4 bar
Pression d'alimentation air : 4 à 6 bar
Température de service max : +80°C

Body : Cast aluminium
Sleeve : Natural rubber, other material on request
Connection : Flanged PN10
Single-acting pneumatic actuator with emergency handwheel
Working pressure : 4 bar
Air pressure supply : 4 up to 6 bar
Max working temperature : +80°C

DN		L (mm)	Kg	Normalement Ouvert	Normalement Fermé
mm	inch			Ref.	Ref.
20	3/4"	95	3	VM8201-07NO-CN0020	VM8201-07NF-CN0020
25	1"	106	4,5	VM8201-07NO-CN0025	VM8201-07NF-CN0025
32	1"	115	5,2	VM8201-07NO-CN0032	VM8201-07NF-CN0032
40	1"1/2	140	7,7	VM8201-07NO-CN0040	VM8201-07NF-CN0040
50	2"	160	9	VM8201-07NO-CN0050	VM8201-07NF-CN0050
65	2"1/2	190	13,5	VM8201-07NO-CN0065	VM8201-07NF-CN0065
80	3"	196	15	VM8201-07NO-CN0080	VM8201-07NF-CN0080
100	4"	260	23	VM8201-07NO-CN0100	VM8201-07NF-CN0100
125	5"	280	33	VM8201-07NO-CN0125	VM8201-07NF-CN0125
150	6"	300	43,5	VM8201-07NO-CN0150	VM8201-07NF-CN0150
200	8"	-	-	VM8201-07NO-CN0200	VM8201-07NF-CN0200

VM9101

Vanne à manchon pneumatique taraudée PN10
Female BSP pneumatic pinch valve



Corps : POM
Manchon : Gomme naturelle anti-abrasion
Raccordement : Femelle BSP
Pression de service : 6 bar
Température de service max : +80°C

Body : POM
Sleeve : Natural rubber
Connection : Female BSP
Working pressure : 6 bar
Max working temperature : +80°C

DN		L (mm)	Kg	Ref.
mm	inch			
10	3/8"	80	0,12	VM9101-0010
15	1/2"	95	0,31	VM9101-0015
20	3/4"	103	0,31	VM9101-0020
25	1"	120	0,50	VM9101-0025
32	1"1/4	135	0,66	VM9101-0032
40	1"1/2	160	0,97	VM9101-0040
50	2"	170	1,50	VM9101-0050

VM8200

Vanne à manchon pneumatique à brides PN10
Flanged pneumatic pinch valve PN10



Corps : Fonte d'aluminium
Manchon : Gomme naturelle anti-abrasion
Brides : Fonte d'aluminium
Raccordement : A brides PN 10
Pression de service :
DN40-150 : 6 bar
DN200 : 4 bar
Température de service max :
-40°C/+80°C

Body : Cast aluminium
Sleeve : Natural rubber
Flanges : Cast aluminium
Connection : Flanged PN10
Working pressure :
DN40-150: 6 bar
DN200: 4 bar
Max working temperature :
-40°C/+80°C

DN	L	Kg	Ref.
40	155	3,2	VM8200-00CN0040
50	183	3,5	VM8200-00CN0050
65	183	5	VM8200-00CN0065
80	228	6	VM8200-00CN0080
100	281	8	VM8200-00CN0100
125	350	12	VM8200-00CN0125
150	420	17	VM8200-00CN0150
200	560	35	VM8200-00CN0200

SUR DEMANDE | ON REQUEST

Autres manchons (EPDM, FPM, Silicone, NBR, CSM, IIR)
Other sleeves (EPDM, FPM, Silicone, NBR, CSM, IIR)



Electrovanne (voir page 310)
Solenoid valve (voir page 310)



RACCORDEMENT & PROTECTION RÉSEAUX

NETWORK CONNECTION & PROTECTION

**JOINTS DE
DÉMONTAGE**
DISMANTLING JOINTS
218 > 219

**ADAPTATEURS DE
BRIDE**
FLANGE ADAPTORS
220 > 221

**RACCORDS
COUPLINGS**
221

VENTOUSES
AIR RELEASE VALVES
222 > 225

PURGEURS
AIR VALVES
226

**SOUPAPES DE
DÉCHARGE**
QUICK RELIEF VALVES
227

**SOUPAPES DE
SÉCURITÉ**
SAFETY VALVES
228

**RÉDUCTEURS DE
PRESSION | PRESSURE
REDUCING VALVES**
229

JOINTS DE DÉMONTAGE

DISMANTLING JOINTS



Résistance à la corrosion

✓ Boulonnerie en acier CLASSE 4.8 ou 6.8 revêtement GEOMET 500® résistant à l'ambiance marine.

Resistance to corrosion

✓ Bolts and nuts steel 4.8 or 6.8 GRADE with GEOMET 500® coating, resistant to marine atmosphere.



Les joints de démontage permettent le montage et le démontage de vannes de sectionnement entre 2 éléments fixes de canalisation.

The dismantling joints allow valves to be mounted and dismantled between two fixed pieces of pipeline.



Nos joints de démontage comportent l'ensemble des tirants sur chacune des pièces pour assurer un montage parfait. Ne nécessite pas d'ajout de boulonnerie.

Ajustable en longueur, les opérations de maintenance sont facilitées !

Our dismantling joints include all of the tie rods on each parts to ensure perfect assembly. No need to add hardware. Length adjustable, maintenance is easy!

JT4203 | JT4243 | JT4253

Joint de démontage fonte ductile
Ductile iron dismantling joint



Résistant à l'ambiance marine
Resistant to marine atmosphere



Corps : Fonte ductile EN-GJS-500-7 (GGG50)

Joint : EPDM

Tiges filetées :

PN10/16 : Acier classe 4.8 revêtu GEOMET 500®

PN25 : Acier classe 6.8 revêtu GEOMET 500®

Température de service max : +4°C/+110°C

Bouchon de protection sur chaque tirant

Body: Ductile iron EN-GJS-500-7 (GGG50)

Sealing: EPDM

Stud bolts:

PN10/16: Steel 4.8 grade with GEOMET 500® coating

PN25: Steel 6.8 grade with GEOMET 500® coating

Max. working temperature: +4°C/+110°C

Protection cap on each rod extremity

Fonte ductile | Ductile iron

DN		PN10		PN16		PN25	
mm	inch	Ref.	Kg	Ref.	Kg	Ref.	Kg
50	2"	voir / see PN16		JT4243-0050	9	-	-
65	2 1/2"			JT4243-0065	11	-	-
80	3"			JT4243-0080	15	-	-
100	4"			JT4243-0100	18	JT4253-0100	22
125	5"			JT4243-0125	27	JT4253-0125	30
150	6"			JT4243-0150	29	JT4253-0150	35
200	8"	JT4203-0200	35	JT4243-0200	39	JT4253-0200	51
250	10"	JT4203-0250	48	JT4243-0250	55	JT4253-0250	74
300	12"	JT4203-0300	53	JT4243-0300	69	JT4253-0300	91
350	14"	JT4203-0350	78	JT4243-0350	89	JT4253-0400	110
400	16"	JT4203-0400	104	JT4243-0400	115	JT4253-0500	178
450	18"	JT4203-0450	138	JT4243-0450	158	JT4253-0600	226
500	20"	JT4203-0500	140	JT4243-0500	198	JT4253-0700	233
600	24"	JT4203-0600	167	JT4243-0600	270	JT4253-0800	312
700	28"	JT4203-0700	235	JT4243-0700	296	JT4253-0900	408
800	32"	JT4203-0800	324	JT4243-0800	386	JT4253-0800	553
900	36"	JT4203-0900	380	JT4243-0900	456	JT4253-0900	700
1000	40"	JT4203-1000	481	JT4243-1000	582	JT4253-1000	930
1200	48"	JT4203-1200	526	JT4243-1200	740	JT4253-1200	1305
1400	56"	JT4203-1400	1250	JT4243-1400	1360	*	*
1500	60"	JT4203-1500	1450	JT4243-1500	1510	*	*
1600	64"	JT4203-1600	1550	JT4243-1600	1690	*	*
1800	72"	JT4203-1800	2350	JT4243-1800	2500	*	*
2000	80"	JT4203-2000	2650	JT4243-2000	2930	*	*

*sur demande / on request



JT4203-EA | JT4243-EA | JT4253-EA

Fonte ductile | Ductile iron

Joint de démontage fonte ductile ACS
Ductile iron dismantling joint ACS



NEW

ACS En cours / In progress



Corps : Fonte ductile EN-GJS-500-7 (GGG50)
Joint : EPDM ACS
Tiges filetées :
PN10/16 : Acier classe 4.8 revêtu GEOMET 500®
PN25 : Acier classe 6.8 revêtu GEOMET 500®
Température de service max : +4°C/-110C°
Bouchon de protection sur chaque tirant

Body: Ductile iron EN-GJS-500-7 (GGG50)
Sealing: EPDM ACS
Stud bolts:
PN10/16: Steel 4.8 grade with GEOMET 500® coating
PN25: Steel 6.8 grade with GEOMET 500® coating
Max. working temperature: +4°C/-110C°
Protection cap on each rod extremity

DN		PN10		PN16		PN25	
mm	inch	Ref.	Kg	Ref.	Kg	Ref.	Kg
50	2"	voir / see PN16		JT4243-EA0050	9	-	-
65	2"1/2			JT4243-EA0065	11	-	-
80	3"			JT4243-EA0080	15	-	-
100	4"			JT4243-EA0100	18	JT4253-EA0100	22
125	5"			JT4243-EA0125	27	JT4253-EA0125	30
150	6"			JT4243-EA0150	29	JT4253-EA0150	35
200	8"	JT4203-EA0200	35	JT4243-EA0200	39	JT4253-EA0200	51
250	10"	JT4203-EA0250	48	JT4243-EA0250	55	JT4253-EA0250	74
300	12"	JT4203-EA0300	53	JT4243-EA0300	69	JT4253-EA0300	91
350	14"	JT4203-EA0350	78	JT4243-EA0350	89	JT4253-EA0400	110
400	16"	JT4203-EA0400	104	JT4243-EA0400	115	JT4253-EA0500	178
450	18"	JT4203-EA0450	138	JT4243-EA0450	158	JT4253-EA0600	226
500	20"	JT4203-EA0500	140	JT4243-EA0500	198	JT4253-EA0700	233
600	24"	JT4203-EA0600	167	JT4243-EA0600	270	JT4253-EA0800	312
700	28"	JT4203-EA0700	235	JT4243-EA0700	296	JT4253-EA0900	408
800	32"	JT4203-EA0800	324	JT4243-EA0800	386	JT4253-EA0800	553
900	36"	JT4203-EA0900	380	JT4243-EA0900	456	JT4253-EA0900	700
1000	40"	JT4203-EA1000	481	JT4243-EA1000	582	*	*
1200	48"	JT4203-EA1200	526	JT4243-EA1200	740	*	*

*sur demande / on request

JT5200 | JT5240 | JT5250 | JT5260

Acier | Steel

Joint de démontage acier
Steel dismantling joint

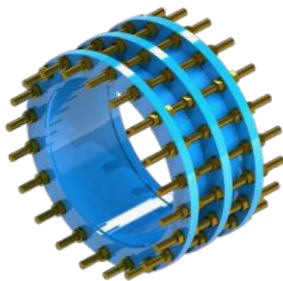

Corps : Acier S-235JR
Joint : EPDM
Tiges filetées : Acier bichromaté 6.8
Température de service max : +4°C/-110C°

Body: Steel S-235JR
Sealing: EPDM
Stud bolts: Bichromated steel 6.8
Max. working temperature: +4°C/-110C°

DN		PN10		PN16		PN25		PN40	
mm	inch	Ref.	Kg	Ref.	Kg	Ref.	Kg	Ref.	Kg
50	2"	JT5200-0050	13	JT5240-0050	13	voir / see PN40		JT5260-0050	15
65	2"1/2	JT5200-0065	15	JT5240-0065	15			JT5260-0065	19
80	3"	JT5200-0080	21	JT5240-0080	21			JT5260-0080	24
100	4"	JT5200-0100	22	JT5240-0100	22			JT5260-0100	33
125	5"	JT5200-0125	28	JT5240-0125	28			JT5260-0125	46
150	6"	JT5200-0150	37	JT5240-0150	37			JT5260-0150	61
200	8"	JT5200-0200	53	JT5240-0200	60	JT5250-0200	73	JT5260-0200	99
250	10"	JT5200-0250	72	JT5240-0250	84	JT5250-0250	101	JT5260-0250	138
300	12"	JT5200-0300	81	JT5240-0300	99	JT5250-0300	132	JT5260-0300	192
350	14"	JT5200-0350	109	JT5240-0350	143	JT5250-0350	200	JT5260-0350	255
400	16"	JT5200-0400	150	JT5240-0400	170	JT5250-0400	243	JT5260-0400	359
450	18"	JT5200-0450	180	JT5240-0450	228	JT5250-0450	295	JT5260-0450	382
500	20"	JT5200-0500	206	JT5240-0500	276	JT5250-0500	344	JT5260-0500	466
600	24"	JT5200-0600	264	JT5240-0600	395	JT5250-0600	462	JT5260-0600	655
700	28"	JT5200-0700	329	JT5240-0700	428	JT5250-0700	627	JT5260-0700	874
800	32"	JT5200-0800	454	JT5240-0800	565	JT5250-0800	908	JT5260-0800	1300
900	36"	JT5200-0900	537	JT5240-0900	663	JT5250-0900	1220	JT5260-0900	1564
1000	40"	JT5200-1000	674	JT5240-1000	887	JT5250-1000	1374	JT5260-1000	1717
1200	48"	JT5200-1200	947	JT5240-1200	1447	JT5250-1200	1720	JT5260-1200	2150
1400	56"	JT5200-1400	1349	JT5240-1400	2027	JT5250-1400	2395	JT5260-1400	2765
1600	64"	JT5200-1600	1809	JT5240-1600	2642	JT5250-1600	3002	-	-
1800	72"	JT5200-1800	2023	JT5240-1800	2910	JT5250-1800	3792	-	-
2000	80"	JT5200-2000	2229	JT5240-2000	3264	JT5250-2000	4600	-	-

* sur demande / on request

RAC./PROTEC. RÉSEAUX
CONNEX./PROTECTION



**ADAPTATEURS DE BRIDE
FLANGE ADAPTORS**



Notre gamme d'adaptateurs de bride autobutable, adaptateurs pour tubes PE, PVC, raccords union universels permettent l'assemblage mécanique d'équipement.

Our range of self-blocking flange adaptors, adaptors for PE/PVC tubes, and universal couplings allow assembly of equipment.

- ✓ Boulonnerie Inox A2.
- ✓ Revêtement EPOXY poudre 250µm certifiée WRAS.
- ✓ Conforme à la norme ACS (en cours).
- ✓ Composant en contact avec le fluide (peinture et joint) WRAS.
- ✓ Conception double perçage PN10/PN16.
- ✓ Large plage d'utilisation.
- ✓ Nuts and bolts Stainless steel A2.
- ✓ 250µm WRAS certified powder epoxy coating.
- ✓ Conform to ACS standard (in progress).
- ✓ Components in contact with the fluid (paint and gasket): WRAS certified.
- ✓ Double-drilled design PN10/PN16.
- ✓ Large range of use.

ADTUNIA

Autobutable | Lockable flange

Adaptateur de bride en fonte ductile - Joint EPDM
Ductile iron flange adapter - EPDM gasket

**BIENTÔT DISPONIBLE
COMING SOON**

NEW



ACS En cours / In progress



Construction : Fonte ductile EN-GJS-500-7 (GGG50)
Joint : EPDM
Boulonnerie : Inox A2
Raccordement : PN10/PN16
Pression max : 16 bar
Autobutable du DN80 au DN600
(La bride et le kit tirants ne sont pas fournis).

Construction: Ductile iron EN-GJS-500-7 (GGG50)
Gasket: EPDM
Nuts and bolts: Stainless steel A2
Connexion: PN10/PN16
Max pressure: 16 bar
Lockable flange DN80 to DN600
(The flange and the tie rod kit are not included).

DN		Ø tube (mm)	Kg	Ref.	Tube					
mm	inch				Fonte grise Cast Iron	Fonte ductile Ductile Iron	Fibro ciment imperial	Acier carbone Carbon steel	Acier Inox Stainless steel	PVC
40	1 1/2	48-60	3,2	ADTUNIA-0040	✓	✓	✓	✓	✓	✓
50	2"	59-72	3,9	ADTUNIA-0050	✓	✓	✓	✓	✓	✓
65	2 1/2	72-85	4,1	ADTUNIA-0065	✓	✓	✓	✓	✓	✓
80	3"	88-98	4,2	ADTUNIA-0080	✓	✓	✓	✓	✓	✓
100	4"	114-118	5,3	ADTUNIA-0100		✓		✓	✓	✓
125	5"	139-144	5,6	ADTUNIA-0125		✓		✓	✓	✓
150	6"	168-170	8,7	ADTUNIA-0150		✓		✓	✓	✓
200	8"	219-222	9	ADTUNIA-0200		✓		✓	✓	✓
250	10"	273-274	11,3	ADTUNIA-0250		✓		✓	✓	✓
300	12"	323-326	19,9	ADTUNIA-0300		✓		✓	✓	✓
350	14"	340-360	22,4	ADTUNIA-0350				✓	✓	✓
400	16"	390-410	28,5	ADTUNIA-0400				✓	✓	✓
450	18"	436-462	35	ADTUNIA-0450				✓	✓	✓
500	20"	500-508	70	ADTUNIA-0500				✓	✓	✓
600	24"	608-636	98,5	ADTUNIA-0600		✓		✓	✓	✓



Pour tube fonte, inox, acier, PVC selon plage de tolérance.
For Cast iron, Stainless steel, Steel and PVC pipes according to the range.



Autobutable : permet le montage d'une contre-bride avec ses tirants.
Lockable version allows a counterflange to be mounted with tie rods.



S'adapte sur une vanne avec portée de joint métallique (montage avec VP à manchette déconseillé).
Adapted to valves with metallic gasket surfaces (mounting with a butterfly valve with a sleeve is advised against).

ADTPEPVC | ADTPEPVCA

Adaptateur de bride pour PE/PVC
Flange adaptor for PE/PVC pipe

**BIENTÔT DISPONIBLE
COMING SOON**

NEW



ACS En cours / In progress

Construction : Fonte ductile EN-GJS-500-7 (GGG50)
Joint : EPDM
Anneau d'adhérence : Laiton CuZn36P03
Raccordement : PN10/PN16
Pression max : 16 bar

Construction: Ductile iron EN-GJS-500-7 (GGG50)
Gasket: EPDM
Grip ring: Brass CuZn36P03
Connexion: PN10/PN16
Max pressure: 16 bar

**Pour tube PE, PVC
For PE, PVC pipes**

DN		Ø tube (mm)	Kg	Ref.
mm	inch			
40	1"1/2	50	1,7	ADTPEPVC-0040
50	2"	63	1,8	ADTPEPVC-0050
65	2"1/2	75	2,4	ADTPEPVC-0065
80	3"	90	2,8	ADTPEPVC-0080
100	4"	110	4	ADTPEPVC-0100
125	5"	125	4,2	ADTPEPVC-0125
125	5"	140	4,2	ADTPEPVCA-0125
150	6"	160	6,5	ADTPEPVC-0150
200	8"	200	8,5	ADTPEPVC-0200
200	8"	225	8,5	ADTPEPVCA-0200
250	10"	250	12,5	ADTPEPVC-0250
300	12"	315	15	ADTPEPVC-0300
400	16"	400	25	ADTPEPVC-0400

S'adapte sur une vanne avec portée de joint métallique (montage avec VP à manchette déconseillé).
Adapted to valves with metallic gasket surfaces (mounting with a butterfly valve with a sleeve is advised against).

**RACCORDS
COUPLINGS**

UNIONUNIA | UNIONUNIB | UNIONUNIC

Raccord union universel en fonte ductile
Ductile iron universal coupling

**BIENTÔT DISPONIBLE
COMING SOON**

NEW



ACS En cours / In progress

Construction : Fonte ductile EN-GJS-500-7 (GGG50)
Joint : EPDM
Boulonnerie : Inox A2
Raccordement : PN10/PN16
Pression max : 16 bar

Construction: Ductile iron EN-GJS-500-7 (GGG50)
Gasket: EPDM
Nuts and bolts: Stainless steel A2
Connexion: PN10/PN16
Max pressure: 16 bar

**Pour tube fonte, inox, acier, PVC.
For cast iron, Stainless steel, Steel and PVC pipes.**

DN		Ø tube (mm)	Kg	Ref.
mm	inch			
40	1"1/2	48-60	2,4	UNIONUNIA-0040
50	2"	59-72	2,5	UNIONUNIA-0050
65	2"1/2	72-85	3,2	UNIONUNIA-0065
80	3"	88-103	4	UNIONUNIA-0080
100	4"	109-128	4,5	UNIONUNIA-0100
125	5"	138-154	6,1	UNIONUNIA-0125
150	6"	159-182	7	UNIONUNIA-0150
175	7"	192-210	8	UNIONUNIA-0175
200	8"	218-235	9,5	UNIONUNIA-0200
225	9"	250-267	12	UNIONUNIA-0225
225	9"	242-262	12	UNIONUNIB-0225
250	10"	272-289	14	UNIONUNIA-0250
300	12"	315-332	16	UNIONUNIA-0300
300	12"	322-339	16	UNIONUNIB-0300
300	12"	340-360	16	UNIONUNIC-0300
350	14"	374-391	23	UNIONUNIA-0350
350	14"	351-378	25	UNIONUNIB-0350
400	16"	390-410	28	UNIONUNIA-0400
400	16"	417-437	28	UNIONUNIB-0400
450	18"	480-500	32	UNIONUNIA-0450
450	18"	454-463	36	UNIONUNIB-0450
500	20"	500-533	39	UNIONUNIA-0500
600	24"	608-636	50	UNIONUNIA-0600

RAC./PROTEC. RÉSEAUX
CONNEX./PROTECTION



VENTOUSES
AIR RELEASE VALVES



Pour eau claire
For clear water



Les ventouses sécurisent le fonctionnement des pièces électromécaniques par l'évacuation (en phase de remplissage) ou l'admission d'air (en phase de vidange) dans les conduites.

The air release valves secure the operation of electromechanical pieces through either evacuation (during the filling phase) or air intake (during the emptying phase) in the piping.

PVS4140S | PVS4150S

Simple effet taraudé (type purge d'air) | Threaded single-acting

Ventouse simple effet taraudée
Threaded type single-acting air release valve



Corps : Fonte ductile ENGJS-400-15 (GGG40)
Flotteur : ABS
Bouchon : Plastique ABS
Raccordement : Femelle BSP à visser
Pression de service max : 16 bar ou 25 bar
Température de service max : +80°C

Body: Ductile iron ENGJS-400-15 (GGG40)
Ball: ABS
Orifice Body: ABS plastic
Connection: Threaded female BSP
Max working pressure: 16 bar or 25 bar
Max. working temperature: +80°C

DN		L (mm)	Kg	PN	Ref.
mm	inch				
25	1"	140	5	16	PVS4140S-0025
25	1"	140	5	25	PVS4150S-0025

PVS4240S | PVS4250S

Simple effet à bride (type purge d'air) | Flanged single-acting

Ventouse simple effet à bride
Flanged type single-acting air release valve



Corps : Fonte ductile ENGJS-400-15 (GGG40)
Flotteur : ABS
Bouchon : Plastique ABS
Raccordement : Bride PN10/16 ou PN25
Pression de service max : 16 bar
Température de service max : +80°C

Body: Ductile iron ENGJS-400-15 (GGG40)
Ball: ABS
Orifice Body: ABS plastic
Connection: Flanged PN10/16 or PN25
Max working pressure: 16 bar
Max. working temperature: +80°C

DN		L (mm)	Kg	PN	Ref.
mm	inch				
25	1"	140	6,1	16	PVS4240S-0025
				25	PVS4250S-0025
40 / 50 / 60 / 65	2"1/2	140	7,7	16	PVS4240S-4065
				25	PVS4250S-4065
80	3"	140	9	16	PVS4240S-0080
				25	PVS4250S-0080
100	4"	140	11	16	PVS4240S-0100
				25	PVS4250S-0100
150	6"	140	16	16	PVS4240S-0150
				25	PVS4250S-0150

PVS4241S | PVS4251S

Simple effet à bride + robinet d'arrêt | Flanges single-acting + ball valve

Ventouse simple effet à bride + robinet d'arrêt
Flanged type single-acting air release valve + ball valve



Corps : Fonte ductile ENGJS-400-15 (GGG40)
Flotteur : ABS
Bouchon : Plastique ABS
Raccordement : Bride PN10/16 ou PN25
Pression de service max : 16 bar
Température de service max : +80°C

Body: Ductile iron ENGJS-400-15 (GGG40)
Ball: ABS
Orifice Body: ABS plastic
Connection: Flanged PN10/16 or PN25
Max working pressure: 16 bar
Max. working temperature: +80°C

DN		L (mm)	Kg	PN	Ref.
mm	inch				
25	1"	140	6,4	16	PVS4241S-0025
				25	PVS4251S-0025
40 / 50 / 60 / 65	2"1/2	140	8	16	PVS4241S-4065
				25	PVS4251S-4065
80	3"	140	9,3	16	PVS4241S-0080
				25	PVS4251S-0080
100	4"	140	9,6	16	PVS4241S-0100
				25	PVS4251S-0100
150	6"	140	13,7	16	PVS4241S-0150



Sur les modèles PVS : fonction de dégazage en continu de petits débits
For PVS models: continuous degassing function for small flows.



PVD4240 | PVD4250 | PVD4260

Double effet à bride | Flanged double-acting

Ventouse double effet à bride
Flanged type double-acting air release valve



Corps : Fonte ductile
ENGJS-400-15 (GGG40)
Flotteur : Polypropylène
Pression de service max :
10 / 16 / 25 / 40 bar
Température de service max :
+80°C

Body: Ductile iron
ENGJS-400-15 (GGG40)
Ball: Polypropylene
Max working pressure:
10 / 16 / 25 / 40 bar
Max. working temperature:
+80°C

DN			PN10 / PN16		PN25		PN40	
mm	inch	L (mm)	Ref.	Kg	Ref.	Kg	Ref.	Kg
40	1 1/2	180	PVD4240-0040	10,5	PVD4250-0040	11	PVD4260-0040	11
50	2"	180	PVD4240-0050	10,5	PVD4250-0050	11	PVD4260-0050	11
65	2 1/2	180	PVD4240-0065	12	PVD4250-0065	12	PVD4260-0065	12
80	3"	180	PVD4240-0080	12	PVD4250-0080	14,5	PVD4260-0080	14,5
100	4"	265	PVD4240-0100	24	PVD4250-0100	24,2	PVD4260-0100	24,2
125	5"	265	PVD4240-0125	26	PVD4250-0125	27	PVD4260-0125	27
150	6"	265	PVD4240-0150	30	PVD4250-0150	31,5	PVD4260-0150	31,5
200	8"	345	PVD4240-0200	54	PVD4250-0200	56	PVD4260-0200	57



2 Fonctions principales :

- . Evacuation d'air à grand débit lors de la mise en eau
- . Admission d'air à grand débit en cas de vidange de la tuyauterie

2 Main Functions:

- . High volume air evacuation when water flow commences
- . High volume air intake in case of pipe emptying

PVT4240 | PVT4250 | PVT4260

Triple effet à bride | Flanged triple-acting

Ventouse triple effet à bride
Flanged type triple-acting air release valve



Corps : Fonte ductile ENGJS-400-15 (GGG40)
2 Flotteurs : Polypropylène
Bouchon : Inox
Pression de service max : 10 / 16 / 25 / 40 bar
Température de service max : +80°C
Double chambres

Body: Ductile iron ENGJS-400-15 (GGG40)
2 Balls: Polypropylene
Orifice Body: Stainless steel
Max working pressure: 10 / 16 / 25 / 40 bar
Max. working temperature: +80°C
Double chamber



A partir du DN250
From DN250

DN			PN10		PN16		PN25		PN40	
mm	inch	L (mm)	Ref.	Kg	Ref.	Kg	Ref.	Kg	Ref.	Kg
40	1 1/2	325	voir / see PN16		PVT4240-0040	17	PVT4250-0040	17	PVT4260-0040	17
50	2"	325			PVT4240-0050	17	PVT4250-0050	17	PVT4260-0050	17
65	2 1/2	325			PVT4240-0065	20	PVT4250-0065	21	PVT4260-0065	21
80	3"	325			PVT4240-0080	21	PVT4250-0080	22	PVT4260-0080	22
100	4"	370			PVT4240-0100	31	PVT4250-0100	34	PVT4260-0100	34
125	5"	370			PVT4240-0125	32	PVT4250-0125	35	PVT4260-0125	35
150	6"	370			PVT4240-0150	34	PVT4250-0150	37	PVT4260-0150	37
200	8"	370			PVT4200-0200	64	PVT4240-0200	64	PVT4250-0200	67
250	10"	633	PVT4200-0250	181	PVT4240-0250	181	PVT4250-0250	185	PVT4260-0250	190
300	12"	685	PVT4200-0300	197	PVT4240-0300	200	PVT4250-0300	205	PVT4260-0300	210
350	14"	880	PVT4200-0350	422	PVT4240-0350	425	PVT4250-0350	432	PVT4260-0350	440
400	16"	880	PVT4200-0400	840	PVT4240-0400	845	PVT4250-0400	940	PVT4260-0400	960
500	20"	1060	PVT4200-0500	1040	PVT4240-0500	1055	PVT4250-0500	1100	PVT4260-0500	1180



3 Fonctions principales :

- . Evacuation d'air à grand débit lors de la mise en eau
- . Admission d'air à grand débit en cas de vidange de la tuyauterie
- . Dégazage en continu des conduites en service

3 Main Functions:

- . High volume air evacuation when water flow commences
- . High volume air intake in case of pipe emptying
- . Continuous degassing

PVTGD4200 | PVTGD4240

Triple effet à bride grand débit | High flow flanged triple-acting

Ventouse grand débit triple effet avec vanne d'arrêt incorporée
High flow triple-acting air release valve with incorporated shut-off valve



Corps : Fonte ductile ENGJS-400-15 (GGG40)
Flotteur : Polyéthylène
Bouchon : Bronze
Température de service max : +80°C
Pression de service max : 10 / 16 bar

Body: Ductile iron ENGJS-400-15 (GGG40)
Ball: Polyethylene
Orifice Body: Bronze
Max. working temperature: +80°C
Max working pressure: 10 / 16 bar

DN			PN10		PN16	
mm	inch	L (mm)	Ref.	Kg	Ref.	Kg
50	2"	460	PVTGD4200-0050	27	PVTGD4240-0050	*
65	2"1/2	460	PVTGD4200-0065	28	PVTGD4240-0065	*
80	3"	460	PVTGD4200-0080	29	PVTGD4240-0080	*
100	4"	530	PVTGD4200-0100	52	PVTGD4240-0100	*
125	5"	530	PVTGD4200-0125	53	PVTGD4240-0125	*
150	6"	530	PVTGD4200-0150	56	PVTGD4240-0150	*

*sur demande / on request

PVQ4240 | PVQ4250 | PVQ4260

Quadruple effet | Four-acting

Ventouse simple chambre quadruple effet
Single chamber, four-function air valve



Corps et couvercle : Fonte ductile ENGJS-400-15 (GGG40)
Flotteur : Polyéthylène
Visserie : Inox A2
Revêtement : Epoxy
Température de service max : -10 / +80°C

Body: Ductile iron ENGJS-400-15 (GGG40)
Ball: Polyethylene
Nuts and bolts: Stainless steel A2
Epoxy coated
Max. working temperature: -10 / +80°C

DN			PN10 ou / or PN16			PN25		PN40	
mm	inch	L (mm)	Ref.	PN	Kg	Ref.	Kg	Ref.	Kg
25	1"	105	PVQ4240-0025	16	8	PVQ4250-0025	8	PVQ4260-0025	8
40	1"1/2	*	PVQ4240-0040	16	*	PVQ4250-0040	*	PVQ4260-0040	*
50	2"	155	PVQ4240-0050	16	11	PVQ4250-0050	11	PVQ4260-0050	11
65	2"1/2	*	PVQ4240-0065	16	*	PVQ4250-0065	*	PVQ4260-0065	*
80	3"	200	PVQ4240-0080	16	19	PVQ4250-0080	37	PVQ4260-0080	37
100	4"	230	PVQ4240-0100	16	25	PVQ4250-0100	40	PVQ4260-0100	40
125	5"	*	PVQ4240-0125	16	*	PVQ4250-0125	*	PVQ4260-0125	*
150	6"	310	PVQ4240-0150	16	40	PVQ4250-0150	43	PVQ4260-0150	43
200	8"	420	PVQ4240-0200 PVQ4200-0200	16 10	90	PVQ4250-0200	96	PVQ4260-0200	96
250	10"	530	PVQ4240-0250 PVQ4200-0250	16 10	185	PVQ4250-0250	190	PVQ4260-0250	190
300	12"	580	PVQ4240-0300 PVQ4200-0300	16 10	200	PVQ4250-0300	210	PVQ4260-0300	210
350	14"	625	PVQ4240-0350 PVQ4200-0350	16 10	417	PVQ4250-0350	430	PVQ4260-0350	430

* sur demande / on request



4 Fonctions principales :

- . Evacuation d'air à grand débit en phase de remplissage des conduites
- . Admission d'air à grand débit en cas de vidange des conduites
- . Dégazage en continu des conduites en service
- . Prévention des coups de bélier pendant le fonctionnement et le démarrage

4 Main Functions:

- . High volume air evacuation when water flow commences
- . High volume air intake in case of pipe emptying
- . Continuous degassing
- . Prevents water hammer during operation and startup

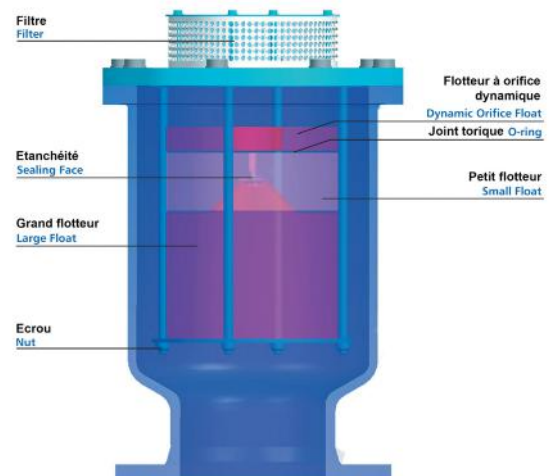

PVTE4246

Triple effet enterrée | Buried triple-acting

Ventouse triple effet enterrée
Buried triple-acting air release valve



Corps : Fonte ductile
ENGJS-400-15 (GGG40)
Axe : Inox 420
Manchette de protection : Inox 304
Raccordement : Bride PN10/16
Simple chambre.
Equippée d'un flotteur thermoplastique
Couvercle plastique
Peut être enterrée sans chambre à vanne

Body: Ductile iron
ENGJS-400-15 (GGG40)
Shaft: Stainless Steel 420
Flanged pipe: Stainless steel 304
Connection: Flanged PN10/16
Single chamber
Thermoplastic air valve
Plastic cap
Can be buried without valve chamber

DN		H : 755 mm	H : 1 055 mm	H : 1 305 mm
mm	inch	Ref.	Ref.	Ref.
50	2"	PVTE4246-S0050	PVTE4246-M0050	PVTE4246-L0050
65	2"1/2	PVTE4246-S0065	PVTE4246-M0065	PVTE4246-L0065
80	3"	PVTE4246-S0080	PVTE4246-M0080	PVTE4246-L0080
100	4"	PVTE4246-S0100	PVTE4246-M0100	PVTE4246-L0100



3 Fonctions principales :

- . Evacuation d'air à grand débit en phase de remplissage des conduites
- . Admission d'air à grand débit en cas de vidange des conduites
- . Dégazage en continu des conduites en service

3 Main Functions:

- . High volume air evacuation when water flow commences
- . High volume air intake in case of pipe emptying
- . Continuous degassing

PVTU4240

Eaux usées | Wastewater

Ventouse triple effet pour eaux usées PN16
Air release valve triple function for sewage PN16



Corps : Fonte ductile ENGJS-400-15 (GGG40)
Pression de service max : 16 bar
Flotteur, axe, boulonnerie : Inox
Raccordement : Brides PN10 ou PN16
Température de service max : +80°C
Avec robinet de purge

Body: Ductile Iron ENGJS-400-15 (GGG40)
Max working pressure: 16 bar
Float, nuts and bolts, stem: Stainless steel
Connection: Flanged PN10 or PN16
Max working temperature: +80°C
With flushing ball valve



Pour eaux usées
For wastewater

DN		L (mm)	Kg	PN	Ref.
mm	inch				
50	2"	480	36	10/16	PVTU4240-0050
80	3"	480	37	10/16	PVTU4240-0080
100	4"	480	38	10/16	PVTU4240-0100
150	6"	480	40	10/16	PVTU4240-0150
				10	PVTU4200-0200
200	8"	480	43	10/16	PVTU4240-0200
				16	PVTU4240-0200



PURGEURS
AIR VALVES



Les purgeurs permettent d'évacuer l'air dans les réseaux.
Air valves allow air to escape from networks.

PSO5246 | PSO5206

Purgeur sonique acier carbone PN10/16
Sonic air valve carbon steel PN10/16



Matière : Acier carbone ST37
Cylindre : Polyéthylène
Tube : Inox 304
Étanchéité : Joint EPDM
Orifice : Laiton
Raccordement : Bride PN10/16

Body: Carbon steel ST37
Cylinder: Polyethylene
Nozzle: Stainless steel 304
Gasket: EPDM
Orifice: Brass
Connection: Flanged PN10/16

DN		L (mm)	Kg	PN	Ref.
mm	inch				
50	2"	650/950	9,5/11	10/16	PSO5246-0050
80	3"	650/950	14/16	10/16	PSO5246-0080
100	4"	750/100	18/21	10/16	PSO5246-0100
150	6"	810/1160	35/40	10/16	PSO5246-0150
200	8"	810/1160	58/64	10	PSO5206-0200 PSO5246-0200
250	10"	830/1160	80/90	10 16	PSO5206-0250 PSO5246-0250



Le purgeur sonique permet l'évacuation de l'air dans la conduite sous un débit contrôlé lors du remplissage en eau. Les coups de bélier sont limités en fin de purge du réseau.

Il s'installe en piquage sur la conduite avec une vanne d'isolement en amont pour permettre le contrôle et la maintenance. Les purgeurs soniques sont associés aux clapets d'entrée d'air pour assurer l'admission d'air en phase de vidange de la conduite.

The sonic air valve allows the evacuation of air in the pipe with a controlled flow during water filling. Water hammers are limited at the end of network purging. It should be installed on connections on the pipe with an isolation valve upstream to allow control and maintenance. Sonic air valves are combined with air intake check valves to ensure air intake when emptying of the pipe.

CEA5245 | CEA5205

Clapet d'entrée d'air acier carbone
Carbon steel air inlet check valve



Corps : Acier carbone ST37
Tige : Inox 304
Palier de guidage : Bronze
Siège : NBR
Raccordement : A brides PN10/16
Pression de service : 10/16 bar (voir tableau)

Body: Carbon Steel ST37
Stem: Inox 304
Bearing: Bronze
Seat: NBR
Connection: Flanged PN10/16
Working pressure: 10/16 bar (see on the table)

DN		L (mm)	Kg	PN	Ref.
mm	inch				
50	2"	280	17	10/16	CEA5245-0050
80	3"	300	25	10/16	CEA5245-0080
100	4"	340	33	10/16	CEA5245-0100
150	6"	400	45	10/16	CEA5245-0150
200	8"	470	66 70	10 16	CEA5205-0200 CEA5245-0200
250	10"	500	90 95	10 16	CEA5205-0250 CEA5245-0250
300	12"	520	105 110	10 16	CEA5205-0300 CEA5245-0300



A monter sur coude ou col de cygne
To mount on a goose neck



Permet l'entrée d'air à grand débit dans la conduite afin d'éviter une dépression en phase de vidange
Allows a high-flow air intake into the pipe to prevent a vacuum from forming in the emptying phase

Types d'installations | Installation types

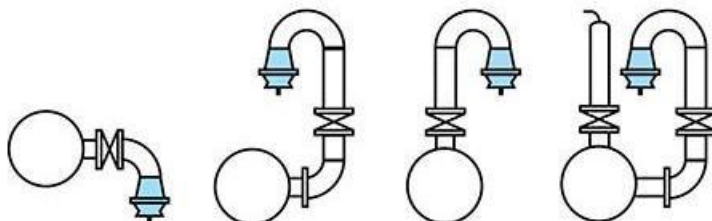



SOUPAPES DE DÉCHARGE
QUICK RELIEF VALVES



Les soupapes sont des organes de sécurité régulièrement associées à une vanne à opercule caoutchouc pour permettre l'isolement et une maintenance aisée (chapitre VOC page 196). Elles permettent d'évacuer la surpression en cas de coup de bélier. Safety valves and steam traps are safety devices used with resilient seat gate valves to isolate the valve and help with maintenance (VOC chapter on page 196). They evacuate over pressurization in the case of water hammer.

SD5209 | SD5249 | SD5259 | SD5269

Soupape de décharge anti-bélier acier
Steel quick relief valve anti-water hammer



Matière : Acier mécano-soudé
Ressort : Acier
Noix : Bronze
Disc : Inox
Étanchéité : Inox
Boulonnerie : Inox
Tarage sur demande
Nous recommandons le tarage à une valeur de 10% au-dessus de la PS.

Material: Welded steel
Spring: Steel
Nut: Bronze
Valve disc: Stainless steel
Seal: Stainless steel
Nuts and bolts: Stainless steel
Set pressure on request
We recommend calibrating 10% below the PS.



Réglage facile sur site
Easy on-site adjustment

				PN10	PN16
DN		L (mm)	Kg	Ref.	Ref.
mm	inch				
50	2"	750	28	SD5209-0050	SD5249-0050
60	2"1/4	750	30	SD5209-0065	SD5249-0065
65	2"1/2				
80	3"	750	32	SD5209-0080	SD5249-0080
100	4"	750	33	SD5209-0100	SD5249-0100
125	5"	750	36	SD5209-0125	SD5249-0125
150	6"	850	71	SD5209-0150	SD5249-0150
200	8"	850	85	SD5209-0200	SD5249-0200
250	10"	*	*	SD5209-0250	SD5249-0250
300	12"	*	*	SD5209-0300	SD5249-0300

				PN25	PN40
DN		L (mm)	Kg	Ref.	Ref.
mm	inch				
50	2"	750	30	SD5259-0050	SD5269-0050
60	2"1/4	750	32	SD5259-0065	SD5269-0065
65	2"1/2				
80	3"	750	35	SD5259-0080	SD5269-0080
100	4"	750	40	SD5259-0100	SD5269-0100
125	5"	750	70	SD5259-0125	SD5269-0125
150	6"	850	110	SD5259-0150	SD5269-0150
200	8"	1 300	250	SD5259-0200	SD5269-0200
250	10"	*	*	SD5259-0250	SD5269-0250
300	12"	*	*	SD5259-0300	SD5269-0300

* sur demande / on request



SOUPAPES DE SÉCURITÉ
SAFETY VALVES



Les soupapes de sécurité protègent les installations contre les dommages d'une surpression du réseau. En cas de dépassement de la pression de tarage, la soupape laisse échapper le fluide jusqu'à ce que la pression redescende au niveau normal.

Safety valves protect installations against damage from network overpressure. In the event that the pressure goes over the setting, the valve allows fluid to escape until the pressure goes back to a normal level.

SR2140

Pour air comprimé | For compressed air

Soupape de sécurité à échappement libre mâle BSP

Male BSP free exhaust safety valve



Corps : Laiton
Ressort : Acier
Press max : 16 bar
Étanchéité : PTFE
Plage de réglage : 2 à 10 bar
Température max de service : +80°C
Raccordement : Mâle BSP

Soupape sans certificat (pré-tarée).
Pour toute demande de tarage, nous consulter.

Body: Brass
Spring: Steel
Pressure max: 16 bar
Tightness: PTFE
Setting range: 2 to 10 bar
Max temperature: +80°C
Connection: Male BSP

Exhaust safety valve without set pressure.
For any request, contact us.

DN		Kg	Ref.
mm	inch		
10	3/8"	0,11	SR2140-0010
15	1/2"	0,14	SR2140-0015
20	3/4"	0,32	SR2140-0020
25	1"	0,56	SR2140-0025
32	1"1/4	0,73	SR2140-0032
40	1"1/2	1,17	SR2140-0040
50	2"	1,62	SR2140-0050

SR2141

Pour eau | For water

Soupape de sécurité à échappement canalisé femelle BSP

Female BSP canalized exhaust safety valve



Corps : Laiton (DN 3/8" au DN 2")
Bronze (DN 2"1/2 au DN 3")
Ressort : Acier
Press max : 16 bar
Étanchéité : PTFE
Plage de réglage : 2 à 12 bar
Température max de service : +80°C
Raccordement : Femelle BSP

Soupape sans certificat (pré-tarée).
Pour toute demande de tarage, nous consulter.

Body: Brass (DN 3/8" to DN 2")
Bronze (DN 2"1/2 to DN 3")
Spring: Steel
Pressure max: 16 bar
Tightness: PTFE
Setting range: 2 to 12 bar
Max temperature: +80°C
Connection: Female BSP

Exhaust safety valve without set pressure.
For any demand, contact us.

DN		Kg	Ref.
mm	inch		
10	3/8"	0,37	SR2141-0010
15	1/2"	0,39	SR2141-0015
20	3/4"	0,63	SR2141-0020
25	1"	1,00	SR2141-0025
32	1"1/4	1,45	SR2141-0032
40	1"1/2	2,10	SR2141-0040
50	2"	3,25	SR2141-0050
60	2"1/2	5,50	SR2141-0065
80	3"	6,80	SR2141-0080

SR2142

Pour vapeur - basse pression / basse T° | For steam - low pressure / low T°

Soupape de sécurité à échappement canalisé femelle BSP avec levier de décharge

Female BSP canalized exhaust safety valve with discharge lever



Corps : Laiton
Ressort : Acier
Press max : 16 bar
Étanchéité : PTFE
Plage de réglage : 5 à 10 bar
Température max de service : +110°C
Raccordement : Femelle BSP

Soupape sans certificat (pré-tarée).
Pour toute demande de tarage, nous consulter.

Body: Brass
Spring: Steel
Pressure max: 16 bar
Tightness: PTFE
Setting range: 5 to 10 bar
Max temperature: +110°C
Connection: Female BSP

Exhaust safety valve without set pressure.
For any request, contact us.

DN		Kg	Ref.
mm	inch		
15	1/2"	0,40	SR2142-0015
20	3/4"	0,70	SR2142-0020
25	1"	1,00	SR2142-0025
32	1"1/4	1,60	SR2142-0032
40	1"1/2	2,20	SR2142-0040
50	2"	3,45	SR2142-0050

SOUPAPES DE SURETÉ | SAFETY VALVES



Autres modèles sur demande
Certificat 3.1 sur demande
Other models on request
3.1 certificate on request





RÉDUCTEURS DE PRESSION
PRESSURE REDUCING VALVES



Les réducteurs de pression réduisent la pression de l'eau dans le but d'avoir une pression constante en aval.
Pressure reducing valves aim to reduce the water pressure in order to have a constant pressure downstream.

DP1103M

Réducteur de pression femelle BSP PN16*

Female BSP pressure reducing valve PN16*

*livré sans manomètre / pressure gauge not included



Corps : Laiton CW617N
Chapeau : Laiton CW617N
Bouchon : Laiton CW617N
Obturbateur : Laiton CW614N
Tige : Laiton CW614N
Joints : NBR
Plage de réglage : 1 à 4 bar
Température de service : +80°C
Raccordement : Femelle BSP
Taraufrage F1/4" pour manomètre

Body: Brass CW617N
Bonnet: Brass CW617N
Cap: Brass CW617N
Shutter: Brass CW614N
Stem: Brass CW614N
Gasket: NBR
Downstream pressure: 1 to 4 bar
Working temperature: +80°C
Connection: Female BSP
Pressure gauge connection F1/4"

DN		L (mm)	Kg	Ref.
mm	inch			
15	1/2"	60	0,38	DP1103M-0015
20	3/4"	60	0,40	DP1103M-0020



DP1103

Réducteur de pression femelle BSP PN25*

Female BSP pressure reducing valve PN25*

*livré sans manomètre / pressure gauge not included



Corps : Laiton CW617N
Chapeau : Laiton CW617N
Bouchon : Laiton CW617N
Obturbateur : Laiton CW614N
Siège : Inox 303
Tige : Laiton CW614N
Joints : NBR
Plage de réglage : 1 à 6 bar
Température de service : +80°C
Raccordement : Femelle BSP
Taraufrage F1/4" pour manomètre

Body: Brass CW617N
Bonnet: Brass CW617N
Cap: Brass CW617N
Shutter: Brass CW614N
Seat: Stainless steel 303
Stem: Brass CW614N
Gasket: NBR
Downstream pressure: 1 to 6 bar
Working temperature: +80°C
Connection: Female BSP
Pressure gauge connection F1/4"

DN		L (mm)	Kg	Ref.
mm	inch			
15	1/2"	77	0,66	DP1103-0015
20	3/4"	85	0,70	DP1103-0020
25	1"	91	1,20	DP1103-0025
32	1 1/4"	118	2,28	DP1103-0032
40	1 1/2"	126	2,17	DP1103-0040
50	2"	142	3,16	DP1103-0050



DP1101

Réducteur de pression femelle BSP PN40*

Female BSP pressure reducing valve PN40*

*livré sans manomètre / pressure gauge not included



Corps : Laiton
Chapeau : Laiton
Joints : Nitrile
Membrane : Acier inox
Pression amont : 40 bar
Plage de réglage :
1/2" à 1" : 0,8 à 5,5 bar
1 1/4 à 4" : 0,8 à 7 bar
Température max : +80°C
Raccordement : Femelle BSP
Taraufrage F1/4" pour manomètre

Body: Brass
Bonnet: Brass
Gaskets: NBR
Lining: Stainless steel
Upstream pressure: 40 bar
Downstream pressure:
1/2" up to 1": 0,8 up to 5,5 bar
1 1/4 up to 4": 0,8 up to 7 bar
Temperature max: +80°C
Connection: Female BSP
Pressure gauge connection F1/4"

DN		L (mm)	Kg	Ref.
mm	inch			
15	1/2"	95	0,48	DP1101-0015
20	3/4"	95	0,50	DP1101-0020
25	1"	95	1,10	DP1101-0025
32	1 1/4"	116	1,30	DP1101-0032
40	1 1/2"	122	1,44	DP1101-0040
50	2"	126	1,60	DP1101-0050
65	2 1/2"	180	1,92	DP1101-0065
80	3"	188	2,60	DP1101-0080
100	4"	202	3,40	DP1101-0100

DP3240

Réducteur de pression aval réglable à brides PN16

Downstream flanged pressure reducing valve PN16



Corps et chapeau : Fonte ductile GGG40
Joint : EPDM
Siège : Acier inox AISI 316
Ressort : Acier
Pression amont : 16 bar
Plage de réglage : 2 à 14 bar
Température max : +60°C
Raccordement : Brides PN16

Body & Bonnet: Ductile iron GGG40
Gasket: EPDM
Seat: Stainless steel AISI 316
Spring: Steel
Upstream pressure: 16 bar
Downstream pressure: 2 to 14 bar
Max temperature: +60°C
Connection: Flanged PN16

DN		L (mm)	Kg	Ref.
mm	inch			
40/50	1 1/2" - 2"	230	13	DP3240-0050
65	2 1/2"	240	18	DP3240-0065
80	3"	260	27	DP3240-0080
100	4"	280	45	DP3240-0100
125	5"	320	90	DP3240-0125
150	6"	350	100	DP3240-0150



Piquage amont et aval en DN1/4" avec vanne de sectionnement à boisseau sphérique et 2 manomètres 0/25 bar.
Upstream and downstream connections for DN1/4" with ball valve and 2 0/25-bar manometers.



COMPENSATEUR EXPANSION JOINT

ELASTOMÈRE

EPDM / NBR

232 > 236

MÉTALLIQUE

METALLIC

236 > 237

CONSEILS TECHNIQUES

TECHNICAL NOTES

238 > 241

COMPENSATEURS

EXPANSION JOINTS



Evitez les vibrations et compensez la dilatation des conduites

✓ Evitez la déformation des tuyauteries

Avoid vibrations and offset the expansion of the pipes

✓ Avoids piping deformations

COMPENSATEURS

La fonction du compensateur est de protéger l'installation des vibrations et des dilatations que pourraient subir les tuyauteries. Les compensateurs acceptent des mouvements latéraux, axiaux et angulaires limités. La diversité des élastomères permet de répondre à tous types d'applications : eau, air, produits abrasifs, vapeur, acides...

EXPANSION JOINTS

The role of expansion joints is to protect installations from vibrations and expansions that the pipework could undergo. The expansion joints allow lateral, axial and limited angular movements. The diversity of elastomers lets it respond to all kinds of applications: water, air, abrasive products, and certain acids. However, beware, they are not meant for correcting misalignments in the pipework.



COMPENSATEURS ÉLASTOMÈRES EPDM RUBBER EXPANSION JOINT

DI7140N

Compensateur Femelle BSP
Female BSP expansion joint



Manchon : Elastomère EPDM
PN : 16 bar
Raccordement : Union 3 pièces fonte galvanisée femelle BSP

Sleeve: EPDM Rubber
PN: 16 bar
Connection: 3-piece female BSP union ends galvanized cast iron

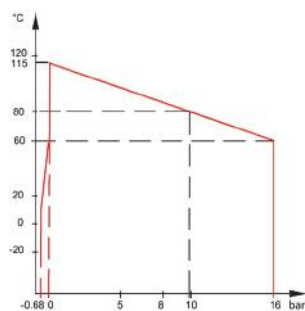

DN		L (mm)	Kg	Ref.
mm	inch			
15	1/2"	200	0,52	DI7140N-0015
20	3/4"	200	0,78	DI7140N-0020
25	1"	200	1,30	DI7140N-0025
32	1 1/4"	200	1,51	DI7140N-0032
40	1 1/2"	200	2,10	DI7140N-0040
50	2"	200	2,71	DI7140N-0050



Renfort : corde nylon
- Compression axiale
- Elongation axiale
- Mouvement latéral

Reinforcement : nylon cord
- Axial compression
- Axial elongation
- Lateral movement



DI7240N | DI724016N

Compensateur EPDM à brides
EPDM Flanged expansion joint



Soufflet externe et interne: Elastomère EPDM
Raccordement : A brides tournantes en acier zingué PN10/16
Pression max : 16 bar
Température de service : -10°C/+80°C

External and internal bellows: EPDM Rubber
Connection: Zinc-plated steel flanges PN10/16
Max pressure: 16 bar
Working temperature: -10°C/+80°C

				PN10/16	
DN		L (mm)	Kg	Ref.	
mm	inch				
32	1 1/4	95	2,93	DI7240N-0032	
40	1 1/2	95	3,60	DI7240N-0040	
50	2"	105	4,23	DI7240N-0050	
65	2 1/2	115	5,21	DI7240N-0065	
80	3"	135	6,20	DI7240N-0080	
100	4"	135	7,00	DI7240N-0100	
125	5"	165	9,53	DI7240N-0125	
150	6"	180	12,60	DI7240N-0150	

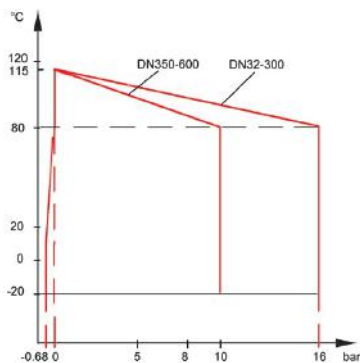

				PN10		PN16	
DN		L (mm)	Kg	Ref.	Ref.	Kg	
mm	inch						
200	8"	205	17,56	DI7240N-0200	DI724016N-0200	17,70	
250	10"	240	20,00	DI7240N-0250	DI724016N-0250	26,60	
300	12"	260	25,00	DI7240N-0300	DI724016N-0300	32,60	
350	14"	265	28,00	DI7240N-0350	DI724016N-0350	39,50	
400	16"	265	47,00	DI7240N-0400	DI724016N-0400	46,12	
450	18"	265	49,00	DI7240N-0450	DI724016N-0450	57,70	
500	20"	265	61,00	DI7240N-0500	DI724016N-0500	61,03	
600	24"	265	68,00	DI7240N-0600	DI724016N-0600	72,80	



Renfort : corde nylon + anneau de renfort acier
- Compression axiale
- Elongation axiale
- Mouvement latéral (voir passeport technique)

Reinforcement: nylon cord + reinforced steel wire
- Axial compression
- Axial elongation
- Lateral movement (see technical sheet)

DI7241NTIRANT | DI7241NTIRANT16

Limiteurs d'élongation pour compensateur DI7240N
Length limiters for expansion joint DI7240N

* prix des tirants uniquement / price of tie rods only



Raccordement : PN10 ou 16
Plaque U : Acier galvanisé
Tiges filetées : Acier galvanisé
Boulons : Acier galvanisé

Connection: PN10 or 16
U plate: Carbon steel
Threaded stems: Carbon steel
Nuts: Carbon steel

			PN10/16	
DN		Ref.	Ref.	
mm	inch			
40	1 1/2	DI7241NTIRANT-0040		
50	2"	DI7241NTIRANT-0050		
65	2 1/2	DI7241NTIRANT-0065		
80	3"	DI7241NTIRANT-0080		
100	4"	DI7241NTIRANT-0100		
125	5"	DI7241NTIRANT-0125		
150	6"	DI7241NTIRANT-0150		



Type de montage
Assembly example

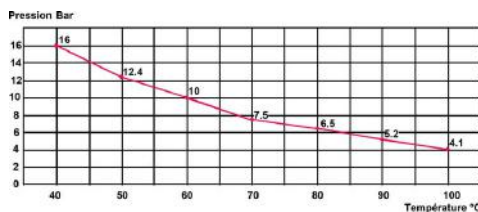

		PN10		PN16	
DN		Ref.		Ref.	
mm	inch				
200	8"	DI7241NTIRANT-0200		DI7241NTIRANT16-0200	
250	10"	DI7241NTIRANT-0250		DI7241NTIRANT16-0250	
300	12"	DI7241NTIRANT-0300		DI7241NTIRANT16-0300	
350	14"	DI7241NTIRANT-0350		DI7241NTIRANT16-0350	
400	16"	DI7241NTIRANT-0400		DI7241NTIRANT16-0400	



Les limiteurs d'élongation sont conçus pour réduire les dommages possibles en cas de mouvements excessifs de la tuyauterie. Les principales causes sont les différences de températures, les montées en pression, les défauts d'alignement de la tuyauterie, la mauvaise position des points fixes ou des guides de tuyauterie.
Control tie rods are designed to minimize possible damage on the expansion joint caused by excessive motion, abnormal temperature fluctuation, pressure surges, piping or failure of anchoring. Where these situations may occur, control units must be used to limit the amount and direction of movement.

DI724116N

EPDM

Compensateur EPDM à brides tournantes PN16 avec limiteurs d'élongation
EPDM Flanged expansion joint PN16 with tie rods

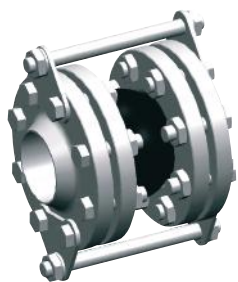

Manchon : Elastomère EPDM
Raccordement : A brides tournantes acier zingué PN16
Pression de service : PN16
Plaque U : Acier galvanisé
Tiges filetées : Acier galvanisé
Boulons : Acier galvanisé
Température de service : -10°C/+115°C

Sleeve: EPDM Rubber
Connection: Zinc plated steel flanges PN16
Working pressure: PN16
U plate: Galvanized steel
Threaded stems: Galvanized steel
Nuts: Galvanized steel
Working temperature: -10°C/115°C

Contre brides non fournies
Counter flanges not supplied

DN		PN	L (mm)	Kg	Ref.
mm	inch				
350	14"	16	265	61	DI724116N-0350
400	16"	16	265	77	DI724116N-0400
450	18"	16	265	91	DI724116N-0450
500	20"	16	265	110	DI724116N-0500
600	24"	16	265	150	DI724116N-0600

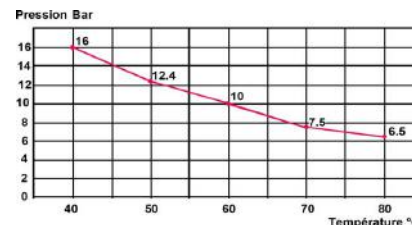

DI7240-BUA

BUTYL ACS L130mm

Compensateur ACS à brides tournantes
ACS flanged expansion joint



Manchon : Elastomère Butyl
Raccordement : A brides tournantes acier carbone PN16
Conditions de service :
90°C à 6 bar
60°C à 16 bar

Sleeve: Butyl Rubber
Connection: Loose carbon steel flanges PN16
Working conditions:
90°C at 6 bar
60°C at 16 bar

ACS

DN		L (mm)	Kg	Ref.
mm	inch			
32	1 1/4"	130	3,3	DI7240-BUA0032
40	1 1/2"	130	3,8	DI7240-BUA0040
50	2"	130	4,5	DI7240-BUA0050
65	2 1/2"	130	5,2	DI7240-BUA0065
80	3"	130	7,1	DI7240-BUA0080
100	4"	130	8	DI7240-BUA0100
125	5"	130	10,5	DI7240-BUA0125
150	6"	130	12,8	DI7240-BUA0150



Tenue à 90°C et jusqu'à 16 bar (à 60°C)
Consultez le passeport pour la courbe P/T°
Up to 90°C and 16 bar (at 60°C)
Consult the technical data sheet for the P/T° curve

DN		L (mm)	Kg	PN10		PN16	
mm	inch			Ref.	Ref.		
200	8"	130	18,2	DI7240-BUA0200		DI724016-BUA0200	
250	10"	130	23,7	DI7240-BUA0250		DI724016-BUA0250	
300	12"	130	30,4	DI7240-BUA0300		DI724016-BUA0300	

DI7240-EA | DI7200 EA

EPDM ACS L130mm

Compensateur ACS à brides tournantes
ACS flanged expansion joint



Manchon : EPDM ACS
Brides : Acier zingué
Raccordement : A brides tournantes PN16 ou PN10
Conditions de service :
80°C à 6 bar

Sleeve: EPDM ACS
Flanges: Galvanized steel
Connection: Carbon steel loose flanges PN16 or PN10
Working conditions:
80°C at 6 bar

ACS



DN		L (mm)	Kg	Ref.
mm	inch			
32	1 1/4"	130	3,13	DI7240-EA0032
40	1 1/2"	130	3,30	DI7240-EA0040
50	2"	130	3,70	DI7240-EA0050
65	2 1/2"	130	4,80	DI7240-EA0065
80	3"	130	5,30	DI7240-EA0080
100	4"	130	6,20	DI7240-EA0100
125	5"	130	8,20	DI7240-EA0125
150	6"	130	11,20	DI7240-EA0150
200	8"	130	16,80	DI7240-EA0200
250	10"	130	21,60	DI7240-EA0250
300	12"	130	30,10	DI7240-EA0300

DN		L (mm)	Kg	Ref.
mm	inch			
200	8"	130	16,80	DI7200-EA0200
250	10"	130	21,60	DI7200-EA0250
300	12"	130	30,10	DI7200-EA0300

DI7240NI

NBR

Compensateur NBR à brides tournantes
NBR flanged expansion joint



Manchon : Elastomère NBR
Raccordement : A brides acier zingué PN10
Pression max : 10 bar
Température de service : -10°C/+80°C

Sleeve: NBR rubber
Connection: Zinc-plated steel flanges PN10
Max pressure: 10 bar
Working temperature: -10°C/+80°C

DN		L (mm)	Kg	Ref.
mm	inch			
32	1"1/4	95	2,95	DI7240NI-0032
40	1"1/2	95	3,46	DI7240NI-0040
50	2"	105	3,98	DI7240NI-0050
65	2"1/2	115	4,89	DI7240NI-0065
80	3"	130	6,57	DI7240NI-0080
100	4"	135	6,74	DI7240NI-0100
125	5"	170	9,36	DI7240NI-0125
150	6"	180	12,71	DI7240NI-0150
200	8"	205	16,80	DI7240NI-0200

DI7240NIL130

NBR L130 mm

Compensateur NBR à brides tournantes - longueur 130 mm
NBR flanged expansion joint - 130 mm length



Manchon : Elastomère NBR
Raccordement : A brides tournantes acier zingué PN10
Pression max : 10 bar
Température de service : -10°C/+80°C

Sleeve: NBR rubber
Connection: Zinc-plated steel flanges PN10
Max pressure: 10 bar
Working temperature: -10°C/+80°C

DN		L (mm)	Kg	Ref.
mm	inch			
32	1"1/4	130	2,74	DI7240NIL130-0032
40	1"1/2	130	2,98	DI7240NIL130-0040
50	2"	130	4,24	DI7240NIL130-0050
65	2"1/2	130	4,98	DI7240NIL130-0065
80	3"	130	5,72	DI7240NIL130-0080
100	4"	130	6,94	DI7240NIL130-0100
125	5"	130	9,18	DI7240NIL130-0125
150	6"	130	10,96	DI7240NIL130-0150
200	8"	130	15,30	DI7240NIL130-0200

DI7242NL130

EPDM L130 mm

Compensateur EPDM à brides tournantes- longueur 130 mm
EPDM flanged expansion joint - 130 mm length



Manchon : Elastomère EPDM
Raccordement : A brides tournantes acier zingué PN10
Pression max : 10 bar
Température de service : -10°C/+80°C

Body: EPDM rubber
Connection: Zinc-plated steel flanges drilled ends PN10
Max pressure: 10 bar
Working temperature: -10°C/+80°C



DN		L (mm)	Kg	Ref.
mm	inch			
32	1"1/4	130	3,13	DI7242NL130-0032
40	1"1/2	130	3,55	DI7242NL130-0040
50	2"	130	4,34	DI7242NL130-0050
65	2"1/2	130	5,30	DI7242NL130-0065
80	3"	130	6,50	DI7242NL130-0080
100	4"	130	7,30	DI7242NL130-0100
125	5"	130	9,45	DI7242NL130-0125
150	6"	130	12,50	DI7242NL130-0150
200	8"	130	17,10	DI7242NL130-0200
250	10"	130	23,90	DI7242NL130-0250
300	12"	130	25,70	DI7242NL130-0300



Renfort : corde nylon + anneau de renfort acier
Reinforcement: nylon cord + reinforced steel wire

DI7251N

EPDM

Compensateur EPDM à brides tournantes avec tirants limiteurs d'élongation PN25
EPDM flanged expansion joint with length limiters PN25



Manchon : Caoutchouc revêtement intérieur/extérieur EPDM
Raccordement : A brides tournantes acier galvanisé PN25
Ecrou, ressort, plaque : Acier
Pression max : 25 bar
Consultez la courbe P/T° sur le passeport technique

Tube: EPDM coated rubber
Connection: Swivel galvanized carbon steel flanges ends PN25
Nuts, spring, plate: Steel
Max pressure: 25 bar
Consult the technical data sheet for the P/T° curve.



DN		L (mm)	Kg	Ref.
mm	inch			
40	1"1/2	240	6,93	DI7251N-0040
50	2"	250	8,1	DI7251N-0050
65	2"1/2	260	9,8	DI7251N-0065
80	3"	280	12,54	DI7251N-0080
100	4"	290	14,24	DI7251N-0100
125	5"	325	18,14	DI7251N-0125
150	6"	340	24,18	DI7251N-0150
200	8"	400	36,59	DI7251N-0200
250	10"	470	48	DI7251N-0250
300	12"	490	69,1	DI7251N-0300



Equipé de limiteurs de déplacement en acier galvanisé
Equipped with galvanized steel control rods

DI7200A

EPDM ASA 150

Compensateur EPDM à brides tournantes - ASA 150
Expansion joint EPDM ASA150



Manchon : EPDM
Raccordement : A brides tournantes acier zingué ASA150lbs
Pression de service max : 10 bar
Température de service : -10°C / +105°C

Sleeve: EPDM
Connection: With zinc-plated ASA150lbs flanges
Max working pressure: 10 bar
Working temperature: -10°C / +105°C

DN		L (mm)	Kg	Ref.
mm	inch			
32	1"1/4	95	2,46	DI7200A-0032
40	1"1/2	95	2,80	DI7200A-0040
50	2"	105	3,90	DI7200A-0050
65	2"1/2	115	4,77	DI7200A-0065
80	3"	130	5,92	DI7200A-0080
100	4"	135	7,26	DI7200A-0100
125	5"	170	9,20	DI7200A-0125
150	6"	180	11,78	DI7200A-0150
200	8"	195	17,40	DI7200A-0200
250	10"	240	24,76	DI7200A-0250
300	12"	260	33,70	DI7200A-0300
350	14"	265	45,90	DI7200A-0350
400	16"	265	53,00	DI7200A-0400
450	18"	265	55,42	DI7200A-0450
500	20"	265	68,80	DI7200A-0500



COMPENSATEURS MÉTALLIQUES
METALLIC EXPANSION JOINTS

DI6340-MVT

PN10/16 - BW

Compensateur métallique à souder - BW
Metallic expansion joint with butt welding ends - BW



Embouts : Acier S235JR
Soufflet : Inox 321
Embout à souder : Acier S235JR
Fourreau interne : Inox 304
Raccordement : BW en acier carbone ST37.2
Pression de service maxi : 16 bar
Température maxi de service :
-80°C / +427°C

Ends: Steel S235JR
Bellow: Stainless steel 321
Welding End: Steel S235JR
Inner sleeve: Stainless steel 304
Connection: BW ends in Carbon Steel ST37.2
Maximum working pressure: 16 bar
Maximum working temperature:
-80°C / +427°C

DN		Mouvement axial Axial movement					
		30 mm			60 mm		
mm	inch	L (mm)	Kg	Ref.	L (mm)	Kg	Ref.
25	1"	210	0,5	DI6340-MVT300025	-	-	-
32	1"1/4	215	0,55	DI6340-MVT300032	-	-	-
40	1"1/2	220	0,6	DI6340-MVT300040	-	-	-
50	2"	220	0,85	DI6340-MVT300050	295	1,5	DI6340-MVT600050
65	2"1/2	220	1,2	DI6340-MVT300065	295	1,7	DI6340-MVT600065
80	3"	220	1,5	DI6340-MVT300080	290	2	DI6340-MVT600080
100	4"	220	2,4	DI6340-MVT300100	300	3	DI6340-MVT600100
125	5"	230	3,2	DI6340-MVT300125	310	5	DI6340-MVT600125
150	6"	245	5	DI6340-MVT300150	345	6	DI6340-MVT600150
200	8"	240	10	DI6340-MVT300200	345	11	DI6340-MVT600200
250	10"	250	15	DI6340-MVT300250	350	16	DI6340-MVT600250
300	12"	260	21	DI6340-MVT300300	360	22	DI6340-MVT600300



Revêtement haute température
High temperature coating



Attention au sens de montage car dispose d'un fourreau de protection interne.
Beware of mounting direction because of internal protective sleeve.



DI6240-MVT

PN16

Compensateur métallique à brides tournantes sur collet Inox 304 PN16
Loose-flanged type metallic expansion joint PN16



CE



Bride : Acier S235JR
Soufflet : Inox 321
Fourreau interne : Inox 304
Raccordement : Par brides tournantes PN10/16 en acier carbone ST37.2
Pression de service maxi : 16 bar
Température maxi de service : -80°C / + 427°C

Flanges : Steel S235JR
Bellow : Stainless steel 321
Inner sleeve : Stainless steel 304
Connection : Ends floating flanges PN10/16 in Carbon Steel ST37.2
Maximum working pressure : 16 bar
Maximum working temperature : -80°C / +427°C



DN		Mouvement axial / Axial movement						
		30 mm			60 mm			
mm	inch	L (mm)	Kg	Ref.	L (mm)	Kg	Ref.	
25	1"	110	2,7	DI6240-MVT300025	-	-	-	
32	1"1/4	115	3,7	DI6240-MVT300032	-	-	-	
40	1"1/2	120	3,8	DI6240-MVT300040	-	-	-	
50	2"	110	5	DI6240-MVT300050	195	5	DI6240-MVT600050	
65	2"1/2	110	6	DI6240-MVT300065	195	6	DI6240-MVT600065	
80	3"	110	7	DI6240-MVT300080	190	8	DI6240-MVT600080	
100	4"	120	8,2	DI6240-MVT300100	200	9	DI6240-MVT600100	
125	5"	130	10,5	DI6240-MVT300125	210	12	DI6240-MVT600125	
150	6"	145	12,5	DI6240-MVT300150	245	15	DI6240-MVT600150	
200	8"	140	18,5	DI6240-MVT300200	245	21	DI6240-MVT600200	
250	10"	150	25,5	DI6240-MVT300250	250	27	DI6240-MVT600250	
300	12"	160	40	DI6240-MVT300300	260	35	DI6240-MVT600300	



Pour fluides soumis à des températures élevées
For fluids subjected to high temperatures

DI6250-MVT

PN25

Compensateur métallique à brides tournantes sur collet Inox 304 PN25
Loose-flanged type metallic expansion joint PN25



CE



Bride : Acier S235JR
Soufflet : Inox 321
Fourreau interne : Inox 304
Raccordement : Par brides tournantes PN25 en acier carbone ST37.2
Température maxi de service : -80°C / + 427°C
Pression de service maxi : 25 bar

Flanges : Steel S235JR
Bellow : Stainless steel 321
Inner sleeve : Stainless steel 304
Connection : Ends floating flanges PN25 in Carbon Steel ST37.2
Maximum working temperature : -80°C / + 427°C
Maximum working pressure : 25 bar



DN		Mouvement axial / Axial movement						
		30 mm			60 mm			
mm	inch	L (mm)	Kg	Ref.	L (mm)	Kg	Ref.	
25	1"	110	3,1	DI6250-MVT300025	-	-	-	
32	1"1/4	115	4,14	DI6250-MVT300032	-	-	-	
40	1"1/2	120	4,27	DI6250-MVT300032	-	-	-	
50	2"	110	5,68	DI6250-MVT300050	195	5,68	DI6250-MVT600050	
65	2"1/2	110	7,68	DI6250-MVT300065	195	7,68	DI6250-MVT600065	
80	3"	110	8,48	DI6250-MVT300080	190	9,7	DI6250-MVT600080	
100	4"	120	11,84	DI6250-MVT300100	200	13	DI6250-MVT600100	
125	5"	130	14,7	DI6250-MVT300125	210	16,80	DI6250-MVT600125	
150	6"	145	18,54	DI6250-MVT300150	245	22,25	DI6250-MVT600150	
200	8"	140	28,08	DI6250-MVT300200	245	31,88	DI6250-MVT600200	
250	10"	150	37,6	DI6250-MVT300250	250	39,81	DI6250-MVT600250	
300	12"	160	58,8	DI6250-MVT300300	260	59,46	DI6250-MVT600300	



Pour fluides soumis à des températures et pressions élevées
For fluids subjected to high temperatures and pressures



Attention au sens de montage sur la conduite. Respecter le sens préférentiel indiqué sur le compensateur par une flèche.
Beware of mounting direction on the pipe. Respect the preferential direction marked by an arrow on the expansion joint.



NOTICE D'INSTALLATION ET D'UTILISATION

USE AND INSTALLATION NOTE



- L'intérieur du joint en caoutchouc et la canalisation doivent être exempts de particules étrangères.
- Il n'y a pas de direction d'écoulement préférée. Les joints en caoutchouc sont bidirectionnels.
- Posez les canalisations de telle sorte que les forces transversales, de flexion et de torsion dommageables soient évitées.
- Protégez l'équipement de la saleté pendant les travaux de construction.
- Des équipements de manutention et de levage appropriés doivent être utilisés pour les travaux d'assemblage. Utilisez des gants pour éviter de vous couper avec les bords tranchants des extrémités ou des tiges. Pendant les travaux d'assemblage, assurez-vous que le joint en caoutchouc est correctement fixé.
- Vous devez uniquement utiliser le joint en caoutchouc non monté tout en respectant toutes les mesures de sécurité.
- Nous recommandons de ne pas peindre ou lubrifier les caoutchoucs.
- Ne pas enterrer ni calorifuger les joints en caoutchouc

- The interior of the rubber joint and the pipeline must be free of foreign particles.
- There is no preferred direction of flow. Rubber joints are bidirectional.
- Lay pipelines such that damaging transverse, bending and torsional forces are avoided.
- Protect equipment from dirt during construction work.
- Suitable materials for handling and lifting equipment should be used for assembly work. Use gloves to avoid cuts from sharp edges of ends or rods. During assembly work, ensure that the rubber joint is fixed adequately.
- You must only operate the unmounted rubber joint while observing all the safety measures.
- We recommend not to paint or lubricate the rubber.
- Do not bury rubber joints.
- Do not insulate rubber joints.

La force de réaction provoquée par la pression interne dans un joint en caoutchouc est calculée comme suit :

$$Fr (N) = P (Kg/cm^2) \times A (cm^2) \times 10$$

Fr = Force de réaction

P = Pression (Pression de service maximale et pression d'essai doivent être prises en compte)

A = Zone transversale efficace

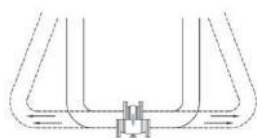

Joint sous pression agit comme un piston
Résultats affichés en travaillant sans ancrage

Joint under pressure acts as a piston
Results shown when working without anchoring

The reaction force caused by internal pressure in a rubber joint is calculated as follows:

$$Fr (N) = P (Kg/cm^2) \times A (cm^2) \times 10$$

Fr = Reaction Force

P = Pressure (Max. working pressure and testing pressure must be considered)

A = Effective cross sectional area

Voici le reste des forces de réaction à absorber par les ancrages du système - Les forces de réaction provoquées par la résistance innée des articulations se déplacent, calculées par la raideur de l'articulation, normalement donnée en N / mm (axial ou latéral) et Nm / ° (angulaire)

- Les forces de réaction causées par le frottement des guides
- En dehors des forces de réaction provoquées par l'installation de jonction elle-même, le poids du système de tuyauterie et les forces centrifuges dans les virages causés par la vitesse du fluide doivent également être pris en compte pour l'ancrage.

The rest of reaction forces to be absorbed by system anchors are as follows:

- Reaction forces caused by the innate joint resistance to move, calculated through the joint stiffness, normally given in N/mm (axial or lateral) and Nm/° (angular)
- Reaction forces caused by the friction of the guides
- Apart from reaction forces caused by the joint installation itself, pipe system weight and centrifugal forces on bends caused by velocity of the fluid must also be considered for anchoring.

ANCRAGE DES POINTS FIXES

Nous appelons des points fixes aux ancrages qui absorbent les forces de réaction. Chaque joint en caoutchouc doit être installé entre deux points fixes dans une section de tube droite. Les points fixes intermédiaires sont ceux qui absorbent simplement les forces causées par la raideur articulaire et le frottement des guides, tandis que les points fixes principaux absorbent aussi les forces causées par la pression interne, les forces centrifuges et les poids non supportés par les guides.

Les points fixes principaux sont normalement situés dans les groupes de pompes, les vannes, les coudes, les croisements, les extrémités de ligne des sections de changement de débit de la tuyauterie.

ANCHORING FIXED POINTS

We call fixed points to the anchors that absorb reaction forces. Every rubber joint has to be installed between two fix points within a straight pipe section. Intermediate fix points are the ones just absorbing forces caused by joint stiffness and friction of guides, whereas main fix points also absorb the forces caused by internal pressure, centrifugal forces and weights not supported by guides. Main fix points are normally located in pump groups, valves, bends, crosses, line ends of flow change sections of the pipework.

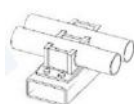

Point fixe soudé pour tuyaux en parallèle
Fixed point welded for pipes in parallel



Point fixe pour coude
Fixed point for elbow



GUIDAGE

Les guides supportent non seulement le poids du système de tuyauterie, mais ils maintiennent également un alignement correct pour que les joints fonctionnent correctement. Il est important de noter que les guides supportant le système de tuyauterie ne sont pas des points fixes. Les guides doivent être positionnés selon certaines règles données plus loin et ils évitent le flambage de la ligne. Des guides spéciaux peuvent être utilisés pour permettre le mouvement dans plus d'une direction.



Guide
Guide with roller stand

GUIDING

Guides not only support the pipe system weight, but also maintain correct alignment so that the joints work adequately. It is important to notice that guides supporting the pipe system are not fixed points. The guides should be positioned according to certain rules given further on and they prevent buckling of the line. Special guides can be used to allow movement in more than one direction.

TIRANTS LIMITEURS

Le but principal des barres de limite est d'absorber la force provoquée par la pression interne, et d'éviter la force de réaction au-dessus des points fixes. Les points fixes seront libérés mais ils sont toujours nécessaires. Un joint avec des tirants limiteurs ne fonctionnera qu'avec des mouvements axiaux. Ils sont normalement utilisés avec une haute pression et de grands DN, ce qui peut nécessiter un ancrage très fort. Ils soulagent également les cadres de la pompe. Les tirants limiteurs peuvent contrôler le soufflet de joint au-dessus de l'extension et / ou de la compression excessive.

LIMIT RODS

The main purpose of limit rods is to absorb the force caused by internal pressure, and avoid reaction force over fixed points. Fix points will be released but they are still necessary. A joint with limit rods will work only with axial movements. They are normally used with high pressure and large DN, that may require very strong anchoring. They also relieve pump frames. Limit rods can control joint bellow over extension and/or over compression.

Directives d'installation pour les joints en caoutchouc absorbant les vibrations et le bruit

Les joints en caoutchouc sont généralement installés dans les groupes de pompage pour absorber les vibrations et le bruit. Le joint en caoutchouc doit être installé près du groupe de pompage, laissant une distance de 1-1,5 DN. Laisser plus de distance dans le cas de médias abrasifs. Le cadre du groupe de pompe doit être correctement ancré pour absorber les forces de réaction et un autre point de fixation doit être réglé immédiatement après le joint de caoutchouc pour limiter l'amplitude des vibrations sur le tuyau. Un bon guidage du tuyau est également nécessaire pour s'assurer que l'équipement fonctionne correctement. L'expansion / la compression du tuyau absorbant doit être réalisée indépendamment.

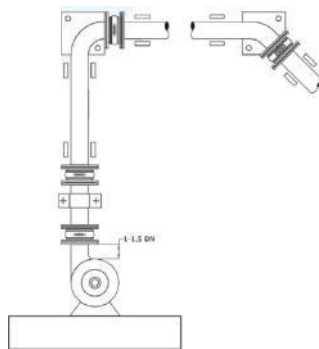

Installation de joints sans barres de limite / Installation of Joints without limit rods

Installation guidelines for rubber joint absorbing vibration and noise

Rubber joints are commonly installed in pump groups to absorb vibration and noise. The rubber joint must be installed near the pump group, leaving a distance of 1-1.5 DN. Leave more distance in case of abrasive media. The pump group frame must be properly anchored to absorb the reaction forces and another fixed point must be set immediately after the rubber joint to limit the vibrations amplitude onto the pipe. Proper guiding of the pipe is also necessary to ensure the equipment works correctly. Absorbing pipe expansion/compression must be carried out independently.

Dans le cas où les points fixes principaux ne pourraient pas être dimensionnés pour absorber la force de réaction provoquée par la pression interne, des tirants limiteurs peuvent être utilisés pour les soulager de telles forces.

Installation de joints avec des tirants limiteurs / Installation of Joints with limit rods

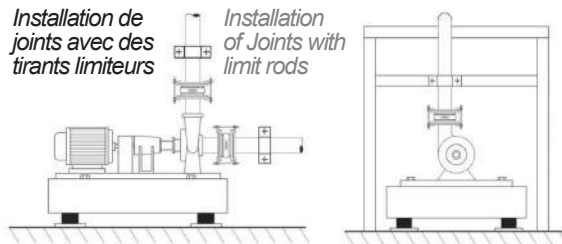

In case main fixed points could not be sized to absorb the reaction force caused by internal pressure, limit rods can be used to relieve them from such forces.

Ci-dessous des exemples et recommandations pour l'emplacement des joints en caoutchouc travaillant comme joints de dilatation avec un ancrage et un guidage appropriés.

Below are some examples and recommendations for location of Rubber Joints working as Expansion Joints with proper anchoring and guiding.

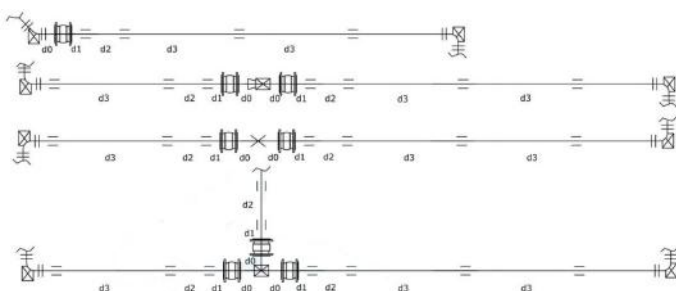

- ☐ Joint de dilatation
- ⊠ Point fixe principal
- × Point fixe intermédiaire

- ≡ Guide
- ⋄ Coude
- ↔ Changement de section

Longueurs recommandées
 $d0 \leq 4 \times DN(\text{mm})$, max.300mm
 $d1 \leq 4 \times DN$
 $d2 \leq 14 \times DN(\text{mm})$
 $d3 \leq 400 \times \sqrt{DN(\text{mm})}$

- ☐ Expansion joint
- ⊠ Main Fixed Point
- × Intermediate Fixed Point

- ≡ Guide
- ⋄ Elbow
- ↔ Section change

Recommended Lengths
 $d0 \leq 4 \times DN(\text{mm})$, max.300mm
 $d1 \leq 4 \times DN$
 $d2 \leq 14 \times DN(\text{mm})$
 $d3 \leq 400 \times \sqrt{DN(\text{mm})}$

Ancrage et guidage des joints travaillant comme joints de dilatation

Anchoring and guiding for Joints working as Expansion Joints



NOTICE D'INSTALLATION ET D'UTILISATION USE AND INSTALLATION NOTE



ATTENTION !

- Assurez-vous que les brides que vous utilisez sont compatibles avec les brides du compensateur.
- Assurez-vous que les faces des brides sont exemptes de graisse et en bon état.
- Les surfaces d'étanchéité des brides doivent être contrôlées afin de s'assurer qu'il n'y a aucun risque que les liens en caoutchouc soient endommagés par des arêtes vives. La longueur de la vis doit être choisie pour assurer que les soufflets en caoutchouc ne peuvent pas être endommagés. Lors de l'installation et du fonctionnement, les joints doivent être protégés de la chaleur rayonnée et de la chaleur de soudage.
- Assurez l'alignement des tuyaux. Les brides doivent bien s'adapter. Assurez-vous que l'écart entre les 2 brides est suffisant pour ne pas endommager les parties en caoutchouc, mais il ne doit pas exister d'espace libre entre les faces des joints en caoutchouc et les surfaces des brides. Les joints peuvent être endommagés s'il est étiré pendant l'assemblage.
- La coquille en caoutchouc elle-même agit comme joint d'étanchéité, donc aucun joint supplémentaire ne doit être ajouté.
- En cas de lubrifiant utilisé, assurez-vous qu'il est compatible avec le caoutchouc.
- Serrer les écrous / boulons opposés graduellement selon la séquence suivante:

WARNING !

- Make sure that counterflanges are compatible with the standard of the Joint flanges.
- Ensure that contact faces of Joint flanges and counterflanges are free of grease and in good condition.
- Sealing surfaces of flanges shall be checked to ensure that there is no risk of the rubber bonds being damaged by sharp inside edges or projections or recesses. The screw length shall be selected to ensure that the rubber bellows cannot be damaged. During installation and operation, the Joints must be protected from radiated heat and welding heat.
- Ensure pipe alignment. Counterflanges should fit smoothly. Make sure that the gap between the 2 counterflanges has enough clearance to fit the equipment without damaging the rubber faces (carefully retract slightly counterflanges if necessary) but, there should be no gap exist between rubber Joint faces and counterflanges faces. Joints may be damaged if stretched during assembly.
- The rubber shell itself acts as a sealing gasket, so no additional gaskets to be added.
- If of any lubricant used, make sure it is compatible with rubber material.
- Tighten opposing nuts/bolts gradually according to the following sequence:

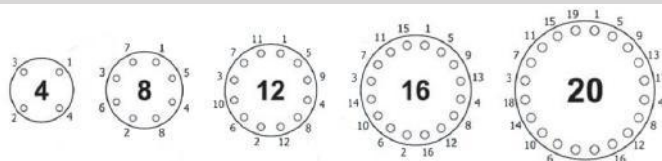

Les valeurs de serrage maximales données sont indiquées à titre de référence. Après le premier serrage, le caoutchouc se détend et le couple de démarrage est à nouveau réduit. Appliquer d'abord un couple de serrage modéré, et resserrer seulement pour corriger toute fuite. Un excès ou un couple irrégulier entraîne des dommages au caoutchouc et raccourcit la durée de vie de l'articulation.

The maximum tightening values given are for reference. After first tightening, the rubber relaxes and starting torque is lower again. Apply a moderate tightening torque at first and only retighten to correct any leakage. An excessive or irregular torque leads to rubber damage and shortens Joint's life span.

- Couples de serrage maximum :

- Maximum tightening torques:

MAX 50-70 Nm

MAX 50-70 Nm

Faites attention aux recommandations suivantes :

Take note of the following recommendations:

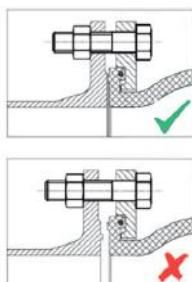

Les faces de brides doivent être planes. N'utilisez pas de contre-brides rainurées.

Counterflanges contact faces should be flat. Do not use grooved counterflanges.

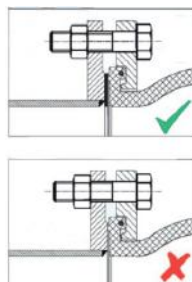

Un joint plat supplémentaire protège les joints en élastomère des extrémités de tuyauterie à arête vive.

An additional flat gasket protects elastomer seals from sharp pipe ends.

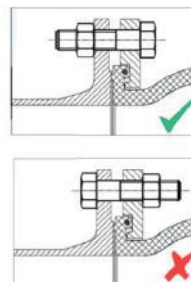

Le caoutchouc peut gonfler en cours de fonctionnement. Assurez-vous que les boulons sont placés de manière à éviter le contact avec le caoutchouc du joint.

Rubber can swell under operation. Make sure bolts are set in such a way to avoid the contact with the joint rubber.



INSTALLATION ET ENTRETIEN DES COMPENSATEURS ÉLASTOMÈRES ET MÉTALLIQUES

ELASTOMER AND METALLIC EXPANSION JOINTS INSTALLATION AND MAINTENANCE

SOUDURE

En cas d'opération de soudure sur la tuyauterie ou aux abords du manchon, il est recommandé de démonter le compensateur ou de le protéger des projections de soudures ou des coups d'arc électriques, etc...

WELDING

In the event of pipe welding it is recommended to dismount the expansion joint.

In case of necessary welding, the joint should be protected from weld splatter and arc strikes, etc.

ISOLATION

S'assurer qu'aucune fuite n'a été créée lors de l'isolation du compensateur.

INSULATION

Before welding take off the expansion joint and protect them from heating and welding projection. Make sure not to insulate over or around the joint. Insulation may make leak detection difficult and restrict joint movement.

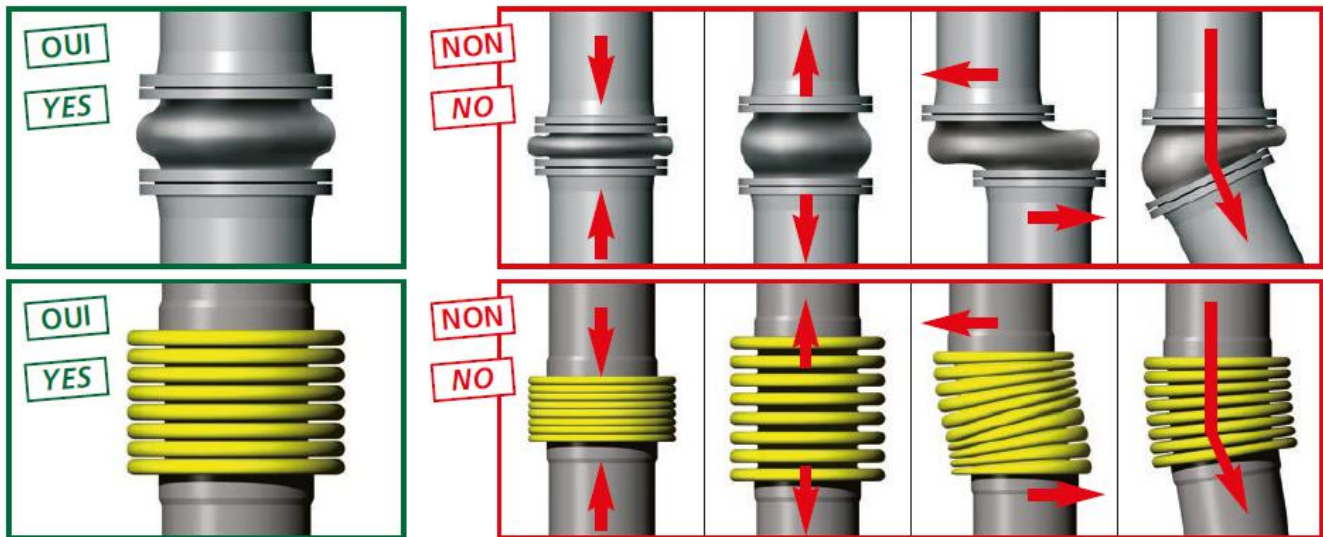



ROBINET DE RÉGULATION

REGULATION VALVE

ROBINETS À SOUPAPE
GLOBE VALVES

244 > 245

ROBINETS À SOUPAPE
À BRIDES | FLANGED
GLOBE VALVES

246

ROBINETS À SOUFFLET
BELLOW VALVES

247

ROBINETS À POINTEAU
NEEDLE VALVES

248

ROBINETS À FLOTTEUR
FLOAT VALVES

248 > 249

ROBINETS DE RÉGULATION

REGULATION VALVES



ROBINET À SOUPAPE

Le robinet à soupape a pour fonction de réguler un débit. Il peut être droit ou d'équerre. L'étanchéité est faite par l'obturateur, appelé aussi disque, qui descend sur le siège du robinet.

Avantages : peut être utilisé sur des pressions et températures élevées, adapté pour du réglage.

ROBINET À SOUFFLET

Le robinet à soupape à soufflet fonctionne sur le même principe qu'un robinet à soupape, mais son étanchéité vers l'extérieur est assurée par un soufflet en plus du presse-étoupe. Il peut être utilisé sur des circuits de vapeur, de gaz, de liquides, de condensats et d'eau, sans entretien.

ROBINETS À POINTEAU

Le robinet à pointeau est un robinet qui permet un réglage précis d'un débit à haute pression pour de petites dimensions de canalisations.

ROBINETS À FLOTTEUR

Le robinet à flotteur a pour fonction le contrôle du niveau le plus haut d'un bassin ou d'une cuve donnée. Son rôle est d'alimenter ou non le bassin et d'en éviter le débordement. Il existe des robinets à flotteur compensé pour les diamètres importants de robinets afin de diminuer la dimension des flotteurs.

GLOBE VALVE

The globe valve's purpose is to adjust the flow. The valve can be either straight or angular. When the obturator, or disk, is lowered against the seat of the globe valve, the valve is watertight.

BELLOW GLOBE VALVE

Bellow valves work on the same principal as globe valves, but its exterior watertightness is ensured by a bellow rather than a packing gland. It can be used in steam, gas, liquid, condensate and water systems, maintenance free.

NEEDLE VALVES

The needle valve is a valve which allows for the precise adjustment of a high pressure flow for small pipe dimensions.

FLOAT VALVES

The float valve's purpose is to control the highest level of a given basin or cistern. Its role is to supply or not supply the basin and to prevent overflows. There are offset float valves for large diameter valves in order to reduce the size of the floats.



ROBINETS À SOUPAPE GLOBE VALVES

INOX | STAINLESS STEEL

R6150

Inox | Stainless steel

Robinet à soupape femelle BSP inox PN16
Stainless steel female BSP globe valve PN16



Corps et chapeau : ASTM A351 CF8M
Etanchéité : PTFE
Raccordement : Femelle BSP
Pression de service max : 16 bar
Température de service : -20°C/+180°C
Commande par volant acier

Body and Bonnet: ASTM A351 CF8M
Seal: PTFE
Connection: Female BSP
Maximum working pressure: 16 bar
Working temperature: -20°C/+180°C
Operation by steel handwheel

DN		L (mm)	Kg	Ref.
mm	inch			
15	1/2"	52	0,26	R6150-0015
20	3/4"	60	0,44	R6150-0020
25	1"	72	0,6	R6150-0025
32	1"1/4	81	0,96	R6150-0032
40	1"1/2	90	1,22	R6150-0040
50	2"	101	1,74	R6150-0050



BRONZE | BRONZE

R2148

Bronze

Robinet à soupape femelle BSP bronze PN20
Bronze female BSP globe valve PN20

**JUSQU'À ÉPUISEMENT DES STOCKS
WHILE STOCKS LAST**



Corps : Bronze
Chapeau : Laiton
Siège : PTFE
Raccordement : Femelle BSP
Pression de service max : 20 bar
Température max : +100°C

Body: Bronze
Bonnet: Brass
Seat: PTFE
Connection: Female BSP
Working pressure: 20 bar
Max temperature: +100°C

DN		L (mm)	Kg	Ref.
mm	inch			
15	1/2"	50	0,26	R2148-0015
20	3/4"	55	0,35	R2148-0020
25	1"	64	0,53	R2148-0025
32	1"1/4	73	0,79	R2148-0032
40	1"1/2	84	1,07	R2148-0040
50	2"	90	1,47	R2148-0050

R2148A

Bronze

Robinet à soupape femelle BSP bronze PN20
Bronze female BSP globe valve PN20

NEW



Corps : Bronze
Chapeau : Bronze
Étanchéité : PTFE
Raccordement : Femelle BSP
Pression de service max : 20 bar
Température max : +170°C
Commande par volant en aluminium peint

Body: Bronze
Bonnet: Bronze
Seal: PTFE
Connection: Female BSP
Working pressure: 20 bar
Max temperature: +170°C
Operation by aluminium-coated handwheel

DN		L (mm)	Kg	Ref.
mm	inch			
15	1/2"	52	0,26	R2148A-0015
20	3/4"	63	0,44	R2148A-0020
25	1"	76	0,70	R2148A-0025
32	1"1/4	84	1,06	R2148A-0032
40	1"1/2	98	1,43	R2148A-0040
50	2"	116	2,38	R2148A-0050

R2143

Robinet à soupape à chapeau union femelle BSP PN25
Female BSP globe valve with union bonnet PN25



Corps : Bronze
Chapeau : Laiton
Siège : Métal
Étanchéité : Inox
Raccordement : Femelle BSP
Pression de service max : 25 bar
Température de service : -10°C/+180°C

Body: Bronze
Bonnet: Brass
Seat: Metal
Seal: Stainless steel
Connection: Female BSP
Maximum working pressure: 25 bar
Working temperature: -10°C/+180°C

DN		L (mm)	Kg	Ref.
mm	inch			
8	1/4"	46	0,27	R2143-0008
10	3/8"	46	0,28	R2143-0010
15	1/2"	56	0,36	R2143-0015
20	3/4"	62	0,65	R2143-0020
25	1"	74	0,90	R2143-0025
32	1"1/4	91	1,42	R2143-0032
40	1"1/2	100	1,79	R2143-0040
50	2"	128	2,98	R2143-0050



R2145

PTFE

Robinet à soupape à chapeau union PTFE PN25
Globe valve with PTFE union bonnet PN25



Corps : Bronze
Chapeau : Laiton
Étanchéité : PTFE
Raccordement : Femelle BSP
Pression de service max : 25 bar
Température de service : -10°C/+180°C

Body: Bronze
Bonnet: Brass
Seal: PTFE
Connection: Female BSP
Maximum working pressure: 25 bar
Working temperature: -10°C/+180°C

DN		L (mm)	Kg	Ref.
mm	inch			
8	1/4"	46	0,27	R2145-0008
10	3/8"	46	0,28	R2145-0010
15	1/2"	56	0,36	R2145-0015
20	3/4"	62	0,65	R2145-0020
25	1"	74	0,90	R2145-0025
32	1"1/4	91	1,42	R2145-0032
40	1"1/2	100	1,79	R2145-0040
50	2"	128	2,98	R2145-0050





**ROBINETS À SOUPAPE À BRIDES
FLANGED GLOBE VALVE**

R3240

Fonte | Cast iron

Robinet à soupape à brides fonte PN16
Cast iron flanged globe valve PN16



Corps et chapeau : Fonte ENGJL-250
Etanchéité : Inox / Inox
Clapet : Fonte grise
Tige & Siège : Inox 304
Raccordement : A brides PN16
Pression de service :
DN15 à DN150 : 16 bar
DN200 : 14 bar
DN250 : 9 bar
DN300 : 6 bar
Température max à 16 bar : +120°C
Consultez la courbe P/T° sur le
passeport technique

Body and Bonnet: Cast iron
ENGJL-250 (GG25)
Seat: Stainless steel / Stainless steel
Disc: Cast Iron
Stem: Stainless steel 304
Connection: Flanged PN16
Working pressure:
DN15 à DN150: 16 bar
DN200: 14 bar
DN250: 9 bar
DN300: 6 bar
Max temperature at 16 bar: +120°C
Consult the technical data sheet for the
P/T° curve.

DN		L (mm)	Kg	Ref.
mm	inch			
15	1/2"	130	3,00	R3240-0015
20	3/4"	150	4,00	R3240-0020
25	1"	160	5,50	R3240-0025
32	1"1/4	180	8,00	R3240-0032
40	1"1/2	200	11,00	R3240-0040
50	2"	230	14,70	R3240-0050
65	2"1/2	290	17,80	R3240-0065
80	3"	310	26,70	R3240-0080
100	4"	350	35,40	R3240-0100
125	5"	400	59,00	R3240-0125
150	6"	480	78,00	R3240-0150
200	8"	600	136,00	R3240-0200
250	10"	730	212,50	R3240-0250
300	12"	850	321,00	R3240-0300

R3243

Fonte | Cast iron

Robinet à soupape à brides fonte PN16 - Haute température
Cast iron flanged globe valve PN16 - High temperature



Corps et chapeau : Fonte ENGJL-250 (GG25)
Clapet : Inox 420
Tige : Inox 420
Raccordement : A brides PN16
Pression de service max : 16 bar (vapeur 10 bar)
Température max : -10°C/+300°C
Consultez la courbe P/T° sur le
passeport technique

Body and Bonnet: Cast iron ENGJL-250 (GG25)
Disc: Stainless steel 420
Stem: Stainless steel 420
Connection: Flanged PN16
Maximum working pressure: 16 bar (steam 10 bar)
Max temperature: -10°C/+300°C
Consult the technical data sheet for the P/T° curve

DN		L (mm)	Kg	Ref.	DN		L (mm)	Kg	Ref.
mm	inch				mm	inch			
15	1/2"	130	3,3	R3243-0015	65	2"1/2	290	17,3	R3243-0065
20	3/4"	150	3,9	R3243-0020	80	3"	310	22,7	R3243-0080
25	1"	160	5	R3243-0025	100	4"	350	35,8	R3243-0100
32	1"1/4	180	6,6	R3243-0032	125	5"	400	52,8	R3243-0125
40	1"1/2	200	9,5	R3243-0040	150	6"	480	72,5	R3243-0150
50	2"	230	12	R3243-0050	200	8"	600	126	R3243-0200



**Haute température
High temperature**



R5260

Acier | Steel

Robinet à soupape à brides acier PN40
Steel flanged globe valve PN40



Corps et chapeau : Acier A216 WCB
Clapet : Inox 420
Tige : Inox 420
Raccordement :
PN25/40 jusqu'au DN150
PN40 à partir du DN200
Pression de service max : 40 bar
(vapeur 10 bar)
Température max : -20°C/+400°C
Consultez la courbe P/T° sur le
passeport technique

Body and Bonnet: Molded steel
A216 WCB
Disc: Stainless steel 420
Stem: Stainless steel 420
Connection:
PN25/40 up to DN150
PN40 from DN200
Maximum working pressure: 40 bar
(steam 10 bar)
Max temperature: -20°C/+400°C
Consult the technical data sheet for
the P/T° curve

DN		L (mm)	Kg	Ref.	DN		L (mm)	Kg	Ref.
mm	inch				mm	inch			
15	1/2"	130	4,40	R5260-0015	65	2"1/2	290	28,00	R5260-0065
20	3/4"	150	5,20	R5260-0020	80	3"	310	36,00	R5260-0080
25	1"	160	5,72	R5260-0025	100	4"	350	50,00	R5260-0100
32	1"1/4	180	11,27	R5260-0032	125	5"	400	73,60	R5260-0125
40	1"1/2	200	12,23	R5260-0040	150	6"	480	95,00	R5260-0150
50	2"	230	15,48	R5260-0050	200	8"	600	175,00	R5260-0200





**ROBINETS À SOUFFLET
BELLOW VALVES**

R4243

Fonte ductile | Ductile iron

Robinet à soufflet à brides fonte ductile PN16
Ductile iron bellow valve flanged PN16



Corps :
DN15-100 : Fonte ductile EN GJS-400-18
DN125-200 : Acier : A216 WCB
Chapeau :
DN15-50 : Acier A216 WCB
DN 65-200 : Fonte ductile EN GJS-400-18
Siège : Inox 410
Soufflet : ASTM A182 F316 (Inox 316)
Volant : Fonte ductile EN GJS-400
Raccordement : A brides PN16
Pression de service max :
DN15-50: 25 bar
DN65-200: 16 bar
(vapeur: 10 bar max)
Température de service : -10°C/+350°C
Consultez la courbe P/T° sur le passeport technique

Body:
DN15-100: Ductile iron EN GJS-400-18
DN125-200: Steel A216 WCB
Bonnet: DN15-50: Steel A216 WCB
DN 65-200: Ductile iron EN GJS-400-18
Seat: Stainless steel 410
Bellow: ASTM A182 F316
Handwheel: Ductile iron EN GJS-400
Connection: langed PN16
Maximum working pressure:
DN15-50: 25 bar
DN65-200: 16 bar
(steam: max 10 bar)
Working temperature: -10°C/+350°C
Consult the technical data sheet for the P/T° curve

DN		L (mm)	Kg	Ref.
mm	inch			
15	1/2"	130	3,20	R4243-0015
20	3/4"	150	3,90	R4243-0020
25	1"	160	4,60	R4243-0025
32	1"1/4	180	6,30	R4243-0032
40	1"1/2	200	8,70	R4243-0040
50	2"	230	12,30	R4243-0050
65	2"1/2	290	16,30	R4243-0065
80	3"	310	22,40	R4243-0080
100	4"	350	34,00	R4243-0100
125	5"	400	50,00	R4243-0125
150	6"	480	74,00	R4243-0150
200	8"	600	130,50	R4243-0200



- . Sans entretien, manœuvre aisée
- . Réglage fin
- . Maintenance free and easy to operate
- . Optimal adjustment

R5263

Acier | Steel

Robinet à soufflet à brides acier PN40
Steel bellow valve flanged PN40



Corps et chapeau : Acier A216 WCB
Étanchéité : Inox
Soufflet : Inox 321
Tige : Inox 303
Pression de service max : 40 bar
Température de service : -20°C/+400°C
ATEX Zone 1&21 et Zone 2&22

Body and Bonnet: ASTM A216 WCB
Seat: Stainless steel
Bellow: Stainless steel 321
Stem: Stainless steel 303
Maximum working pressure: 40 bar
Working temperature: -20°C/+400°C
ATEX Zone 1&21 and Zone 2&22

DN		L (mm)	Kg	Ref.
mm	inch			
15	1/2"	130	4,70	R5263-0015
20	3/4"	150	5,50	R5263-0020
25	1"	160	6,17	R5263-0025
32	1"1/4	180	11,25	R5263-0032
40	1"1/2	200	12,49	R5263-0040
50	2"	230	15,45	R5263-0050
65	2"1/2	290	20,50	R5263-0065
80	3"	310	34,00	R5263-0080
100	4"	350	44,00	R5263-0100
125	5"	400	77,00	R5263-0125
150	6"	480	110,00	R5263-0150
200	8"	600	205,00	R5263-0200



- . Sans entretien et manœuvre aisée.
- . Système anti rotation évitant les risques de torsion du soufflet.
- . Chapeau et presse-étoupe boulonné facilitant les opérations de maintenance, double sécurité pour étanchéité vers l'extérieur (soufflet + PE).
- . Maintenance free and easy to operate.
- . Anti-rotation system avoids the risk of bellow torsion.
- . Bolted bonnet and packing gland facilitate maintenance, double security for external watertightness.



**Pour fluides non corrosifs, vapeur, gaz, fluides caloporteurs.
Modèle sans entretien.
For non-corrosive fluids, vapor, gas, and heat transfer fluids.
Easy maintenance.**



**ROBINETS À POINTEAU
NEEDLE VALVES**

RP2100

Bronze

Robinet à poiteau femelle BSP bronze PN25
Bronze female BSP needle valve PN25



Corps : Bronze
Chapeau, siège et axe : Laiton
Étanchéité : Métal
Raccordement : Femelle BSP
Pression de service max : 25 bar
Température de service : -10°C/+180°C

Body: Bronze
Bonnet, seat and stem: Brass
Seal: Metal
Connection: Female BSP
Maximum working pressure: 25 bar
Working temperature: -10°C/+180°C

DN		L (mm)	Kg	Ref.
mm	inch			
8	1/4"	46	0,25	RP2100-0008
10	3/8"	46	0,27	RP2100-0010
15	1/2"	55	0,33	RP2100-0015
20	3/4"	62	0,55	RP2100-0020

RP6191BSP

Inox | Stainless steel

Robinet à poiteau femelle BSP inox PN400
Stainless steel female BSP needle valve PN400



Corps, axe et chapeau : ASTM A351 CF8M (Inox 316)
Garniture presse étoupe : PTFE
Étanchéité : Métal
Raccordement : Femelle BSP
Pression de service max : 400 bar
Température de service : -20°C/+180°C

Body, stem & bonnet: ASTM A351 CF8M (Stainless steel 316)
O'Ring: PTFE
Seal: Metal
Connection: Female BSP
Maximum working pressure: 400 bar
Working temperature: -20°C/+180°C

DN		L (mm)	Kg	Ref.
mm	inch			
8	1/4"	55	0,27	RP6191BSP-0008
10	3/8"	55	0,25	RP6191BSP-0010
15	1/2"	56	0,40	RP6191BSP-0015
20	3/4"	71	0,82	RP6191BSP-0020
25	1"	-	1,125	RP6191BSP-0025



**ROBINETS À FLOTTEUR
FLOAT VALVES**

RF1100

Faible pression | Low pressure

Robinet à flotteur laiton mâle BSP - Faible pression
Brass male BSP float valve - Low pressure



Corps : Laiton
Siège : Laiton
Flotteur : PVC ou cuivre (voir tableau)
Raccordement : Mâle BSP
Température max : +80°C

Body: Brass
Seat: Brass
Float: PVC or copper (see chart)
Connection: male BSP
Max temperature: +80°C

RF1100						Flotteur / float		
DN		bar	L	Kg	Ref.	Kg	Cuivre/ Copper	PVC
mm	inch							
10	3/8"	2	175	0,143	RF1100-0010	0,036	RFFLOT-CUIVRE090	RFFLOT-PVC090
15	1/2"	2	175	0,225	RF1100-0015	0,036	RFFLOT-CUIVRE090	RFFLOT-PVC090
20	3/4"	2	300	0,500	RF1100-0020	0,200	RFFLOT-CUIVRE120	RFFLOT-PVC120
25	1"	2	300	0,490	RF1100-0025	0,200	RFFLOT-CUIVRE150	RFFLOT-PVC150
32	1 1/4"	1	500	0,940	RF1100-0032	0,300	RFFLOT-CUIVRE180	RFFLOT-PVC180
40	1 1/2"	1	500	1,430	RF1100-0040	0,300	RFFLOT-CUIVRE200	RFFLOT-PVC180
50	2"	1	500	1,890	RF1100-0050	0,500	RFFLOT-CUIVRE220	RFFLOT-PVC220
65	2 1/2"	1	600	4,150	RF1100-0065	2,000	RFFLOT-CUIVRE250	RFFLOT-PVC300
80	3"	1	650	5,100	RF1100-0080	2,000	RFFLOT-CUIVRE300	RFFLOT-PVC300
100	4"	1	700	7,950	RF1100-0100	2,000	RFFLOT-CUIVRE300	RFFLOT-PVC300



Prix RF1100 + Flotteur à rajouter
RF1100 price + Float to add

RF3240

Robinet à flotteur compensé d'équerre

Angle type balanced float valve



Corps : Fonte GG25
 Obturateur : Inox 304
 Flotteur : Inox 304
 Etanchéité : NBR
 Raccordement :
 DN40-125 : A brides PN16
 DN150-300 : A brides PN10
 Pression de service : 16 bar ou 10 bar
 Température de service : -10°C/+120°C

Body: Cast Iron GG25 Epoxy coated
 Disc: Stainless steel 304
 Float: Stainless steel
 Seat NBR
 Connection:
 DN40-125: Flanged PN16
 DN150-300: Flanged PN10
 Working pressure: 16 bar or 10 bar
 Working temperature: -10°C/+120°C

DN		Kg	Ref.
mm	inch		
40	1"1/2	14	RF3240-0040
50	2"	16	RF3240-0050
65	2"1/2	20	RF3240-0065
80	3"	27	RF3240-0080
100	4"	35	RF3240-0100
125	5"	50	RF3240-0125
150	6"	75	RF3240-0150
200	8"	124	RF3240-0200
250	10"	163	RF3240-0250
300	12"	180	RF3240-0300

RF3241

Robinet à flotteur compensé droit

Straight type balanced float valve



Corps : Fonte GG25
 Obturateur : Inox 304
 Flotteur : Inox 304
 Etanchéité : NBR
 Raccordement :
 DN40-125 : A brides PN16
 DN150-300 : A brides PN10
 Pression de service : 16 bar ou 10 bar
 Température de service : -10°C/+120°C

Body: Cast Iron GG25 Epoxy coated
 Disc: Stainless steel 304
 Float: Stainless steel 304
 Seat: NBR
 Connection:
 DN40-125: Flanged PN16
 DN150-300: Flanged PN10
 Working pressure: 10 bar ou 10 bar
 Working temperature: -10°C/+120°C

DN		L	Kg	Ref.
mm	inch			
40	1"1/2	180	15	RF3241-0040
50	2"	200	17	RF3241-0050
65	2"1/2	240	26	RF3241-0065
80	3"	260	32	RF3241-0080
100	4"	300	38	RF3241-0100
125	5"	350	65	RF3241-0125
150	6"	400	90	RF3241-0150
200	8"	500	160	RF3241-0200
250	10"	730	200	RF3241-0250

RF6141 | RFIFLOT

Robinet à flotteur Inox

Stainless steel float valve



Corps : Inox 316
 Tige : Inox 316
 Flotteur : Inox 316
 Joint : Silicone
 Raccordement : Filetage cylindrique BSP mâle
 Pression de service : 16 bar
 Température de service max: -60°C/+200°C
 Conditions de service :
 16 Bar : -60°/+120°C
 15 Bar : -60°/+180°C
 14 Bar : -60°/+200°C

Body: Stainless steel 316
 Stem: Stainless steel 316
 Float: Stainless steel 316
 Seal: Silicone
 Raccordement: BSP Threaded connection
 Working pressure: 16 bar
 Max Working temperature: -60°C/+200°C
 Working condition:
 16 Bar: -60°/+120°C
 15 Bar: -60°/+180°C
 14 Bar: -60°/+200°C

DN		bar	Ref.
mm	inch		
10	3/8"	3	RF6141-0010-3B RFIFLOT-60x120mm
		5	RF6141-0010-5B RFIFLOT-90mm
		15	RF6141-0010-15B RFIFLOT-110mm
		16	RF6141-0010-16B RFIFLOT-150x60mm
15	1/2"	1,9	RF6141-0015-1.9B RFIFLOT-60x120mm
		2,8	RF6141-0015-2.8B RFIFLOT-90mm
		4,5	RF6141-0015-4.5B RFIFLOT-110mm
		5,8	RF6141-0015-5.8B RFIFLOT-150x60mm
		13	RF6141-0015-13B RFIFLOT-150mm
20	3/4"	1,7	RF6141-0020-1.7B RFIFLOT-90mm
		2,5	RF6141-0020-2.5B RFIFLOT-110mm
		3,5	RF6141-0020-3.5B RFIFLOT-150x60mm
		11	RF6141-0020-11B RFIFLOT-150mm
		25	1"
1,5	RF6141-0025-1.5B RFIFLOT-150x60mm		
3,5	RF6141-0025-3.5B RFIFLOT-200x80mm		
4,5	RF6141-0025-4.5B RFIFLOT-150mm		
5,5	RF6141-0025-5.5B RFIFLOT-150mm		
10,5	RF6141-0025-10.5B RFIFLOT-250x95mm		

DN		bar	Ref.
mm	inch		
32	1"1/4	1,5	RF6141-0032-1.5B RFIFLOT-150mm
		3,5	RF6141-0032-3.5B RFIFLOT-250x95mm
		8	RF6141-0032-8B RFIFLOT-200mm
		10	RF6141-0032-10B RFIFLOT-300x115mm
40	1"1/2	2	RF6141-0040-2B RFIFLOT-250x95mm
		4	RF6141-0040-4B RFIFLOT-200mm
		7	RF6141-0040-7B RFIFLOT-300x115mm
		10	RF6141-0040-10B RFIFLOT-350x130mm
50	2"	3	RF6141-0050-3B RFIFLOT-200mm
		5	RF6141-0050-5B RFIFLOT-300x115mm
		8	RF6141-0050-8B RFIFLOT-350x130mm
		10	RF6141-0050-10B RFIFLOT-300mm
65	2"1/2	2	RF6141-0065-2B RFIFLOT-200mm
		2,5	RF6141-0065-2.5B RFIFLOT-300x115mm
		5	RF6141-0065-5B RFIFLOT-300mm

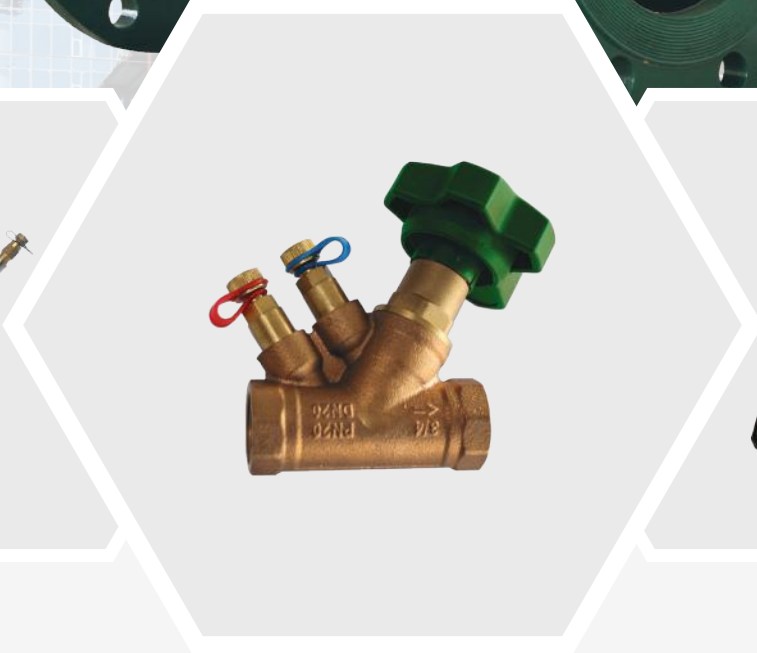
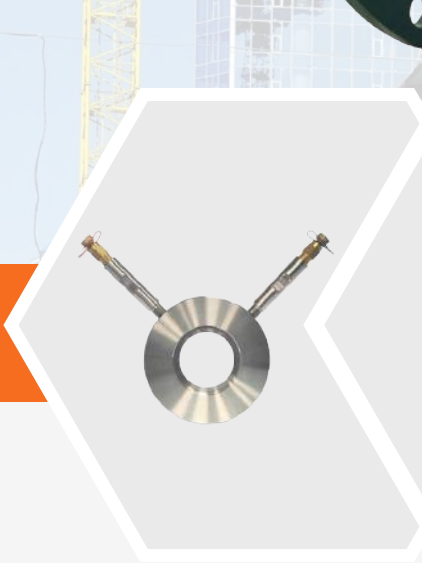

SOLUTIONS D'ÉQUILIBRAGE

BALANCING SOLUTIONS

**ROBINETS
D'ÉQUILIBRAGE**
BALANCING VALVES
254 > 257

PURGEURS D'AIR
AIR TRAPS
258

ANTI-BÉLIERS
WATER HAMMER
ARRESTER **259**

ROBINETS D'ÉQUILIBRAGE

BALANCING VALVES



Pour projets HVAC
For HVAC projects

Pourquoi équilibrer une installation ?

Why balancing the installation ?

CONFORT COMFORT

L'équilibrage hydraulique permet d'apporter les débits requis et donc de fournir en tout point de l'installation les quantités de chaleur désirées. Dans un même immeuble, par exemple, un certain nombre de locaux atteignent difficilement, voire parfois jamais, les températures prescrites, alors que d'autres locaux sont «surchauffés». Ce problème résulte généralement d'une mauvaise répartition des débits qui ne permet pas aux boucles de régulation d'assurer correctement leur mission.

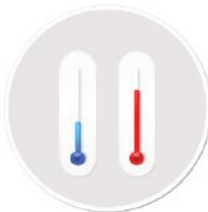

The hydraulic balancing brings the required flows to provide the desired amount of heat at any point of the installation. In the same building, for example, a number of rooms can hardly reach, sometimes never, the required temperatures, whereas other rooms are over heated. This problem generally results from a bad distribution of the flows, which does not allow the control loops to properly fulfill their mission.

ECONOMIES D'ÉNERGIE ENERGY SAVINGS

Bien entendu, le fait d'apporter les puissances nécessaires, et uniquement celles-ci, en tous points d'une installation permet de ne dépenser que les quantités d'énergie nécessaires. Dans un immeuble, par exemple, les locaux des étages inférieurs peuvent se trouver «surchauffés», alors que ceux des étages supérieurs n'arrivent pas à atteindre les températures désirées, ou seulement tard dans la journée, ce qui oblige à des durées de production de chaleur plus longues et plus régulières. Une installation bien équilibrée voit tous ses locaux bénéficier d'une même température dans le même temps, ce qui induit une production de chaleur beaucoup moins longue dans la durée, avec des démarrages beaucoup plus espacés. Dans de bonnes conditions d'équilibrage, un réseau hydraulique peut apporter des économies d'énergie de 10 à 20 %, voire plus dans certains cas.



Of course only bringing the needed power to only the necessary points of the installation makes it possible to spend the minimum amount of energy required. In a building, for example, the lower-level rooms can be over heated and the upper-level rooms do not manage to reach the desired temperature, or only late in the day, which implies longer and more regular heat production periods. A well balanced installation allows all its rooms benefit from same temperature at the same time, which leads to a much shorter heat production, with startups much more spaced out. In well-balanced conditions, a hydraulic network can offer between 10 and 20% in energy savings, and in some cases even more.

CONTRÔLE CONTROL

Grâce notamment à la présence d'organes de réglage et d'équilibrage sur votre installation, il est possible de mesurer soit le débit, soit la pression différentielle, soit la température en tout point du réseau hydraulique. Ceci permet le contrôle du bon fonctionnement de l'installation, et dans le cas contraire, conduit précisément à l'élément qui cause un trouble.



Thanks to the adjustment and balancing components in your installation, it is possible to measure the flows, the differential pressures, or the temperatures at any point of the hydraulic network. This makes it possible to control the proper functioning of the installation, and if the installation malfunctions, it precisely shows which element is causing the problem.

REAMENAGEMENT REFITTING

L'installation de départ étant équilibrée, il est possible de réaliser ultérieurement une ou plusieurs extensions, sans crainte de gêner le bon fonctionnement du réseau déjà existant. Ces extensions sont à équilibrer à leur tour, puisque le débit de départ est augmenté.



With the initial installation being balanced, it is possible to install one or some extensions later on, without fear of disturbing the proper functioning of the already existing network. Of course, these extensions will have to be balanced as well, since the starting flow will increase.



ÉQUILIBRAGE DANS UNE INSTALLATION SIMPLIFIÉE
BALANCING IN A SIMPLIFIED INSTALLATION

L'installation comporte trois colonnes montantes identiques, sans aucun robinet d'équilibrage. Le débit en sortie de chaudière, est calculé pour que chaque colonne reçoive un débit identique.

La colonne 1, plus proche de la chaudière donc avec une résistance plus faible, reçoit un débit supérieur à son besoin, elle est donc sur-alimentée.

En revanche, la colonne 3 manque de débit, car il est «happé» par les colonnes précédentes. Elle est sous-alimentée.

Cela va donc poser un gros problème de confort, puisque on ne va pas pouvoir atteindre les débits voulus dans les colonnes. Les apports calorifiques ne sont pas conformes à ceux calculés.

Les locaux alimentés par la colonne 1 seront surchauffés, alors que les locaux de la colonne 3 seront sous chauffés.

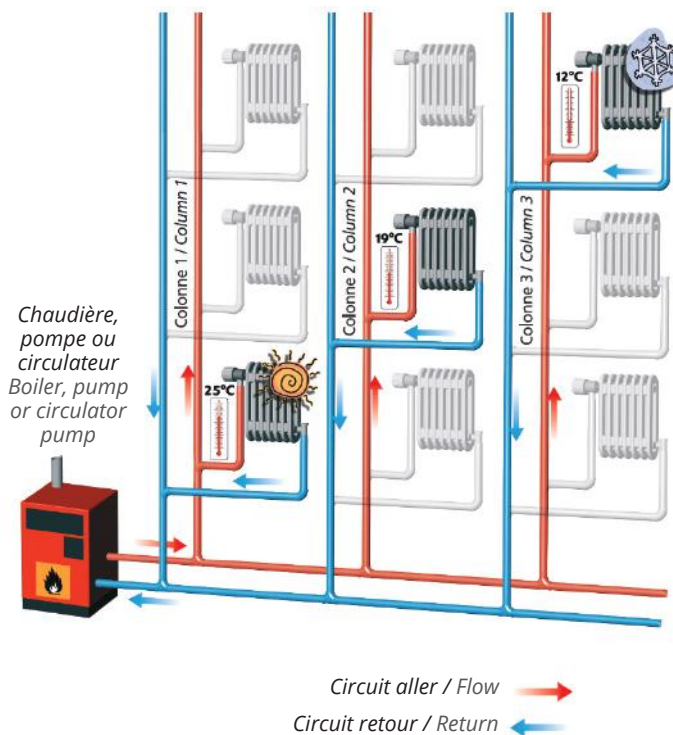

The installation is made up of 3 identical rising columns, without any balancing valves. The flow at exit of boiler is calculated so that each column receives the identical flow.

The first column, close to the boiler thus with a lower resistance, receives a flow higher than its needs, therefore it is over supplied.

On the other hand, the third column misses flow, because it is snatched by the preceding columns and therefore is under supplied.

This causes a problem of comfort, since it is not possible to reach the desired flows in all of the columns. The energy intake does not match those that were calculated. The rooms supplied by the first column will be overheated, whereas the rooms on the third column will be under heated.

Pour équilibrer l'installation, on monte des Robinets d'équilibrage RC 2106 sur les circuits de retour. Ceux-ci vont répartir équitablement les débits dans les colonnes.

L'ouverture des robinets sera différente, le robinet de la colonne 3 sera peut-être complètement ouvert (réglé sur la position 4.9), alors que le robinet en colonne 1 sera réglé sur 2 et le robinet de la colonne 2 sur la position 3.

Le robinet d'équilibrage RC4240 en tête de distribution absorbe une partie de la perte de charge du réseau afin de faire fonctionner les autres robinets d'équilibrage dans une plage de réglage plus optimal.

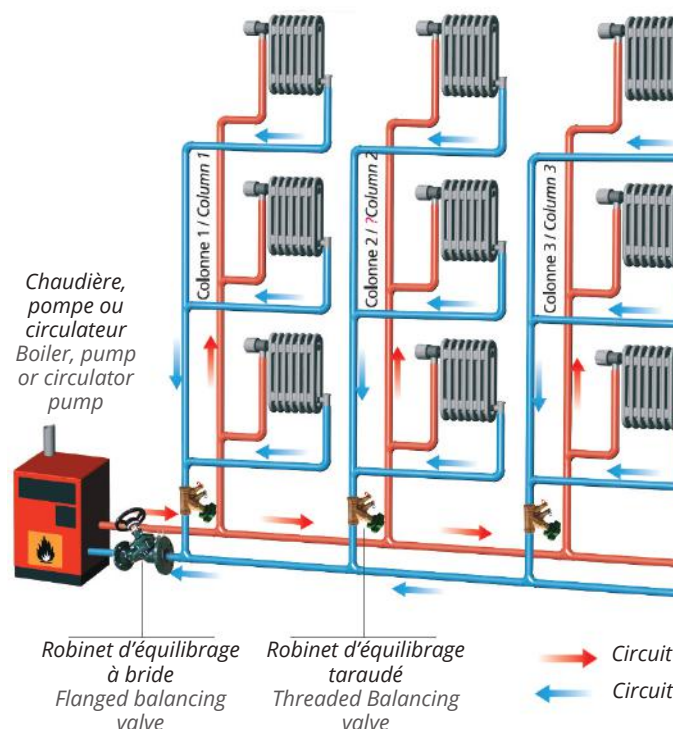

In order to balance the installation, we assemble RC 2106 balancing valves on the return circuits. They will equally distribute the flows in the columns.

The opening of the valves will be different: the tap on the third column will be perhaps completely opened (regulated at position 4.9), whereas the valve on the first column will be regulated at 2 and the valve on the second column at position 3.

The RC4240 balancing valve at the beginning of the distribution absorbs a part of the pressure loss of the network in order to make the other balancing valves function in a more suitable adjustment range.



ROBINETS D'ÉQUILIBRAGE BALANCING VALVES

RC2106

Robinet d'équilibrage femelle BSP bronze PN20
Bronze female BSP balancing valve PN20



Corps : Bronze C83600
Clapet : Laiton CW602N
Prises de pression : Laiton
Étanchéité : EPDM
Raccordement : Femelle BSP
Pression de service : 20 bar
Température de service : -25°C/+110°C
Contrôle des débits par 2 prises de pression

Body: Bronze C83600
Disc: Brass CW602N
Pressure test points: Brass
Seal: EPDM
Connection: Female BSP
Working pressure: 20 bar
Working temperature: -25°C/+110°C
Head loss controlled by 2 pressure test point

DN		L	Kg	Ref.
mm	inch			
15	1/2"	80	0,58	RC2106-0015
20	3/4"	86,5	0,66	RC2106-0020
25	1"	105	0,88	RC2106-0025
32	1"1/4	123,5	1,07	RC2106-0032
40	1"1/2	125	1,45	RC2106-0040
50	2"	144	1,97	RC2106-0050



- Réglage précis grâce à sa tête 40 positions + clapet parabolique : lui confère une meilleure précision.
- Pertes de charge réduites grâce à son siège oblique.
- Donnée instantanée.
- Bouchons de purge pour vidange ou remplissage.
- Position mémoire avec vis de blocage dans la tête.

- Precise adjustment thanks to its 40-position head + parabolic plug: giving it better precision.
- Low head losses thanks to its slanted seat.
- Instantaneous test points.
- Drain plugs for draining and filling.
- Position memory with set screw in the head.



Permet de réaliser des réglages précis et l'équilibrage sur les circuits de chauffage, de sanitaire et de climatisation.
Allows exact regulation of heating and cooling systems.

NEW

EN OPTION POUR RC2106
OPTION FOR RC2106

Prise de pression
Test point



	Matière / Material	Ref.
Pièce de rechange : Prise de pression Spare parts: Test point	Pour / For RC2106 Laiton / Brass	RC2106-TESTPOINT

Prix pour la paire (couleur bleue et rouge)
Price for the pair (blue and red color)

RC4240 | RC4250

Orifice variable | Variable orifice

Robinet d'équilibrage à brides - orifice variable PN16 ou PN25
Flanged type balancing valve - variable orifice PN16 or PN25



Corps : Fonte ductile GGG40
Chapeau : Fonte ductile GGG40
Clapet : Fonte ductile GGG40 + EPDM
Prises de pression : Acier
Étanchéité : EPDM
Raccordement : A brides
Température de service : -10°C/+120°C
2 prises de pression acier

Body: Ductile iron GGG40
Bonnet: Ductile iron GGG40
Disc: Ductile iron GGG40 + EPDM
Pressure test points: Steel
Seal: EPDM
Connection: Flanged
Working temperature: -10°C/+120°C
2 steel pressure test point

Orifice variable :
réglage amont-aval
Variable orifice: upstream
downstream adjustment

DN		L	Kg	PN16		PN25	
mm	inch			Ref.	Kg	Ref.	
65	2"1/2	290	17	RC4240-0065	17	RC4250-0065	
80	3"	310	20	RC4240-0080	20	RC4250-0080	
100	4"	350	29	RC4240-0100	29	RC4250-0100	
125	5"	400	40	RC4240-0125	40	RC4250-0125	
150	6"	480	52	RC4240-0150	52	RC4250-0150	
200	8"	600	113	RC4240-0200	113	RC4250-0200	
250	10"	730	185	RC4240-0250	185	RC4250-0250	
300	12"	850	248	RC4240-0300	248	RC4250-0300	
350	14"	980	408	RC4240-0350	408	RC4250-0350	
400	16"	1100	547	RC4240-0400	547	RC4250-0400	
450	18"	1200	684	RC4240-0450	684	RC4250-0450	
500	20"	1250	836	RC4240-0500	836	RC4250-0500	
600	24"	1450	-	RC4240-0600	-	RC4250-0600	



- Robinet d'équilibrage à brides avec siège oblique équipé de 2 prises de pression permettant une excellente précision du réglage.
- Indicateur d'ouverture avec limiteur de course.
- Prise de pression permettant la vidange et le remplissage.
- Position mémoire avec vis de blocage dans la tête.

- These are Y-pattern globe valves fitted with two pressure tests. Valves provide flow measurement, regulation and isolation.
- Position indicator with a stroke limiter.
- Fast draining and padding thanks to the drain plug.
- Position memory with set screw in the head.



RC4241 | RC4251

Orifice fixe | Fixed orifice

Robinet d'équilibrage à brides - orifice fixe PN16 ou PN25
Flanged type balancing valve - fixed orifice PN16 or PN25



Corps : Fonte ductile GGG40
Chapeau : Fonte ductile GGG40
Clapet : Fonte ductile GGG40 + EPDM
Prises de pression : Acier
Étanchéité : EPDM
Raccordement : A brides
Température de service : -10°C/+120°C
2 prises de pression acier

Orifice fixe :
réglage en amont
Fixed orifice: upstream configuration

Body: Ductile iron GGG40
Bonnet: Ductile iron GGG40
Disc: Ductile iron GGG40 + EPDM
Pressure test points: Steel
Seal: EPDM
Connection: Flanged
Working temperature: -10°C/+120°C
2 steel pressure test point

DN		L	Kg	PN16		PN25	
mm	inch			Ref.	Kg	Ref.	
65	2 1/2"	290	17	RC4241-0065	17	RC4251-0065	
80	3"	310	20	RC4241-0080	20	RC4251-0080	
100	4"	350	29	RC4241-0100	29	RC4251-0100	
125	5"	400	40	RC4241-0125	40	RC4251-0125	
150	6"	480	52	RC4241-0150	52	RC4251-0150	
200	8"	600	113	RC4241-0200	113	RC4251-0200	
250	10"	730	185	RC4241-0250	185	RC4251-0250	
300	12"	850	248	RC4241-0300	248	RC4251-0300	
350	14"	980	408	RC4241-0350	408	RC4251-0350	
400	16"	1100	547	RC4241-0400	547	RC4251-0400	
450	18"	1200	684	RC4241-0450	684	RC4251-0450	
500	20"	1250	836	RC4241-0500	836	RC4251-0500	
600	24"	1450	-	RC4241-0600	-	RC4251-0600	



- . Orifice fixe.
- . Robinet d'équilibrage à brides avec siège oblique équipé de 2 prises de pression permettant une excellente précision du réglage.
- . Indicateur d'ouverture avec limiteur de course.
- . Prise de pression permettant la vidange et le remplissage.

- . Fixed orifice.
- . These are Y-pattern globe valves fitted with two pressure tests. Valves provide flow measurement, regulation and isolation.
- . Position indicator with a stroke limiter.
- . Fast draining and padding thanks to the drain plug.

NEW EN OPTION POUR | OPTION FOR
RC4240-4250-4241-4251
OP6446-6456

Prise de pression
Test point



	Matière / Material	Ref.
Pièce de rechange : Prise de pression Spare parts: Test point	Pour / For RC4240-RC4250 RC4241-RC4251 OP6446-OP6456 Laiton / Brass	RCTESTPOINT6

Prix pour la paire (couleur bleue et rouge)
Price for the pair (blue and red color)

RC7240N

Ensemble de réglage PN16
Regulation unit PN16

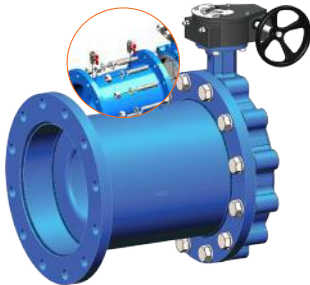

Composé de :
- 1 vanne papillon oreilles taraudées PN16 à réducteur
- 1 manchette de compensation en acier S235 revêtement époxy
- 2 prises de pression (BS1152D 2 voies)
- 1 diaphragme de régulation
visserie en acier zinguée
- rondelle, écrou raccord
Raccordement ASA150Lbs sur demande

Comprised of:
- 1 Lugged type butterfly valve PN16 with gearbox
- 1 steel S235 compensation sleeve, epoxy coated
- 2 2-way ball valves (BS1152D)
- 1 regulating diaphragm
zinc-coated steel nuts and bolts
- nuts and bolts
ASA150Lbs connection on request

DN		L	Ref.
mm	inch		
300	12"	500	RC7240N-0300
350	14"	537	RC7240N-0350
400	16"	600	RC7240N-0400
450	18"	650	RC7240N-0450
500	20"	700	RC7240N-0500
600	24"	800	RC7240N-0600



- . Permet de régler le débit et de mesurer la pression différentielle grâce aux prises de pression situées de part et d'autre du diaphragme.
- . Régulation de la perte de charge.
- . Adjustment assembly featuring a lugged type butterfly valve and a compensation sleeve. Sets the flow and measures differential pressure thanks to the pressure taps situated on either side of the diaphragm.
- . Regulates head loss

OP6446 | OP6456

Orifices de réglage de débit
Flow adjustment holes



Corps et extensions : Acier inoxydable 304
Orifices de tests : Laiton
Raccordement : Entre brides PN16 ou PN25
Température de service : -10°C/+120°C

Fiabilité de mesure de +/- 3% dans des conditions d'écoulement standard.

Body and extension tubes: Stainless steel 304
Tests points: Brass
Connection: Between flanges PN16 or PN25
Working temperature: -10°C/+120°C

Accuracy of flow +/- 3% at normal velocities.

DN			L (mm)	PN16		PN25	
mm	inch	Kg		Ref.	Kg	Ref.	
50	2"	-	-	OP6446-0050	-	OP6456-0050	
65	2"1/2	18	1,5	OP6446-0065	1,5	OP6456-0065	
80	3"	18	1,8	OP6446-0080	1,8	OP6456-0080	
100	4"	18	2	OP6446-0100	2	OP6456-0100	
125	5"	18	2,6	OP6446-0125	2,6	OP6456-0125	
150	6"	18	3	OP6446-0150	3	OP6456-0150	
200	8"	18	4	OP6446-0200	4	OP6456-0200	
300	12"	18	6,5	OP6446-0300	6,5	OP6456-0300	
350	14"	21	13	OP6446-0350	13	OP6456-0350	
400	16"	21	15,3	OP6446-0400	15,3	OP6456-0400	
450	18"	21	20	OP6446-0450	20	OP6456-0450	
500	20"	21	21,9	OP6446-0500	21,9	OP6456-0500	
600	24"	25	36	OP6446-0600	36	OP6456-0600	

DN supérieurs sur demande
Other DN on request



Permet de réguler un débit avec l'orifice calibré et mesurer le débit par ΔP .
Les extensions permettent le calorifugeage.
Peut-être utilisé seul ou couplé avec une vanne permettant la régulation.
Allows flow regulation with a calibrated orifice and measurement of the flow by ΔP .
The extensions allow for insulation.
Can be used either alone or with a valve to regulate.





Appareil de mesure | Measuring device



Pour faciliter l'équilibrage des installations de chauffage et de climatisation, TECOFI a développé son appareil TEC'CONTROL combinant un boîtier de mesure et un logiciel (dispose des données des plus grandes marques).

To facilitate the balancing of heating and air conditioning systems, TECOFI has developed TEC'CONTROL device combining a measurement box and software (has the largest data brands).

RCCONTROLA

Mesureur électronique pour robinet d'équilibrage TEC'CONTROL
Electronic measurer for balancing valve TEC'CONTROL



Valise anti-choc complète comprenant :

- 1 Mesureur électronique
- 2 Prises de pression
- 2 Flexibles

Connection via Bluetooth avec application Tec'Control dédiée disponible sur Android et IOS.

Interface de mesure conviviale.

Boîtier IP65

Design ergonomique

- ✓ Location sur demande
- ✓ Fonctionne avec système de batterie à recharger sur prise standard.

NEW

Shockproof case comprised of:

- 1 Electronic Measurer
- 2 Test points
- 2 Hoses

Wireless connection with Tec'Control application available on Android and IOS. User friendly interface.

Case according IP65 protection level.

- ✓ Rent on request
- ✓ Works with battery system to be recharged on a standard socket.

Ref.

RCCONTROLA



Compatible avec plus de 17 marques !
Compatible with more than 17 brands !

Retrouvez l'application Tec'Control
disponible sur Android et Apple Store !

Find the Tec'Control app
in the Android and App Store!

Entrée de pression positive Positive pressure inlet

Entrée de pression négative
Negative pressure inlet

Bouton de mise à zéro
Reset button

Clavier
Keypad

Couvercle de la batterie
Battery cover



- Le mesureur Tec'Control est conçu pour l'équilibrage hydraulique des systèmes de chauffage et de refroidissement. Il permet de mesurer la pression statique, les pressions différentielles ainsi que le débit des réseaux.
- Le débit peut être mesuré dans toutes les branches du système hydraulique et le réseau entier peut être équilibré.

- The Tec'Control instrument is designed for hydraulic balancing of heating and cooling systems. It measures static pressure, differential pressures and flow in the systems.
- The flow can be measured in all branches of the whole hydraulic system and the whole system can be balanced.



PURGEURS D'AIR : PROTECTION DES RESEAUX AIR TRAPS: NETWORK PROTECTION



Purgeurs d'air | Air traps

La fonction du purgeur d'air est d'éliminer l'air présent dans la tuyauterie pendant le remplissage de l'installation avec de l'eau. La force du poids du flotteur agit sur un levier qui abaisse l'obturateur et permet l'évacuation de l'air.

The purpose of a float trap is to remove air present in the piping while the installation is being filled with water. The force of the weight of the float trap acts as a lever which brings down the valve and allows air to escape.

PU1100

Purgeur d'air automatique à flotteur

Automatic float air trap



Corps : Laiton chromé
Flotteur : Laiton
Chapeau : Laiton chromé
Pression max : 10 bar
Raccordement : Mâle BSP
Température max : +90°C

Body: Chromed brass
Float: Brass
Bonnet: Chromed brass
Max pressure: 10 bar
Connection: male BSP
Max temperature: +90°C

DN		L (mm)	Kg	Ref.
mm	inch			
10	3/8"	67,5	0,11	PU1100-0010
15	1/2"	67,5	0,12	PU1100-0015
20	3/4"	86	0,24	PU1100-0020
25	1"	86	0,24	PU1100-0025



À ajouter à la vanne opercule caoutchouc à partir du DN300 sur vanne verticale
For resilient seat gate valve from DN300 on vertical valve



Penser à monter une vanne d'isolement en amont type BS1152A, page 263.
Think about adding an isolation valve upstream ref BS1152A, on page 263.

PU3200

Purgeur d'air automatique à flotteur

Automatic float air trap



Corps : Laiton
Flotteur : Inox
Pression de service : 16 bar
Raccordement : Femelle BSP 3/4"
Température de service : -20°C/+120°C

Body: Brass
Float: Stainless steel
Working pressure: 16 bar
Connection: Female BSP 3/4"
Working temperature: -20°C/+120°C

DN		Ref.
mm	inch	
20	3/4"	PU3200-0020



Réf PU3200 : pour grand débit
Ref PU3200: For high flow



Penser à monter une vanne d'isolement en amont type BS1152C, page 264.
Think about adding an isolation valve upstream ref BS1152C, page 264.





ANTI-BÉLIERS : PROTECTION DES RESEAUX WATER HAMMER ARRESTER: NETWORK PROTECTION



Anti-béliers | water hammer arrester

✓ Amortissement des coups de bélier générés par l'arrêt ou le démarrage brutal des pompes et vannes des circuits de fluide.

✓ Damps water hammer generated by the stopping or abrupt start of pumps and valves in fluid circuits.

AB2140

Anti-bélier à membrane - bronze

Bronze no water hammer



Corps : Bronze
Membrane : NBR
Raccordement : Mâle BSP
Pression de service : 10 bar
Température de service : -15°C/+80°C

Body: Bronze
Diaphragm: NBR
Connection: Male BSP
Working pressure: 10 bar
Working temperature: -15°C/+80°C

DN		L (mm)	Kg	Ref.
mm	inch			
15	1/2"	74	0,3	AB2140-0015
20	3/4"	82	0,4	AB2140-0020
25	1"	95	0,5	AB2140-0025
40	1"1/2	120	1,4	AB2140-0040
50	2"	162	3,2	AB2140-0050



Penser à monter une vanne d'isolement en amont type BS1152C, page 264.
Think about adding an isolation valve upstream ref BS1152C, page 264.

AB6142

Anti-bélier à membrane - Inox 316

Stainless steel 316 no water hammer



Corps : Inox 316
Membrane : NBR
Raccordement : Mâle BSP
Pression de service : 12 bar
Température de service : -15°C/+80°C

Body: Stainless steel 316
Diaphragm: NBR
Connection: Male BSP
Working pressure: 12 bar
Working temperature: -15°C/+80°C

DN		L (mm)	kg	Ref.
mm	inch			
15	1/2"	74	0,3	AB6142-0015
20	3/4"	82	0,4	AB6142-0020
25	1"	95	0,5	AB6142-0025
40	1"1/2	120	1,4	AB6142-0040
50	2"	162	3,2	AB6142-0050



Penser à monter une vanne d'isolement en amont type BS1152C, page 264.
Think about adding an isolation valve upstream ref BS1152C, page 264.

AB3240

Anti-bélier à membrane - fonte

Cast iron no water hammer



Corps : Fonte EN-GJL 250
Membrane : NBR
Raccordement : Bride PN16
Pression de service : 12 bar
Température de service : -15°C/+80°C

Body: Cast iron EN-GJL 250
Diaphragm: NBR
Connection: Flange PN16
Working pressure: 12 bar
Working temperature: -15°C/+80°C

DN		L (mm)	kg	Ref.
mm	inch			
80	3"	240	16	AB3240-0080
100	4"	330	30	AB3240-0100
125	5"	330	30	AB3240-0125
150	6"	420	67	AB3240-0150
200	8"	510	93	AB3240-0200



Amortissement des coups de bélier générés par l'arrêt ou le démarrage brutal des pompes et des vannes sur les installations.
Damps water hammer generated by the stopping or abrupt start of pumps and valves in fluid circuits.



Penser à monter une vanne de sectionnement en amont.
Think about adding a block valve upstream.



ROBINET BOISSEAU SPHÉRIQUE

BALL VALVE

LAITON

BRASS

262 > 268

- Taraudé / Threaded 262
- À brides / Flanged 268
- 3 voies / 3-way 268

ACIER

STEEL

269 > 273

- Taraudé / Threaded 269
- 3 pièces / 3-piece 270
- À brides / Flanged 272
- 3 voies / 3-way 273

INOX

STAINLESS STEEL

274 > 288

- Taraudé / Threaded 274
- 3 pièces / 3-piece 277
- À brides / Flanged 282
- 3 voies / 3-way 287

NOTICE TECHNIQUE

TECHNICAL NOTES

289

ROBINET BOISSEAU SPHÉRIQUE

BALL VALVE

ROBINET À BOISSEAU

Le robinet à boisseau est un robinet quart de tour dont la sphère percée pivote sur un axe.

Ce type de robinet permet d'avoir peu de perte de charge, il se manœuvre simplement et rapidement, résistant, il assure une bonne étanchéité et son encombrement est réduit.

BALL VALVE

The ball valve is a quarter turn valve with a drilled ball that turns on an axis.

This type of valve has low head loss and is resistant. The valve is quick closing with perfect water tightness and a short face to face design.

LAITON | BRASS



ROBINETS À BOISSEAU SPHÉRIQUE LAITON TARAUDÉ THREADED BRASS BALL VALVES

BS1143

PN25 - ACS

Robinet à boisseau sphérique passage intégral femelle BSP - laiton - ACS

Full bore ball valve female BSP - Brass - ACS



ACS

JUSQU'À ÉPUISEMENT DES STOCKS
WHILE STOCKS LAST

Corps : Laiton nickelé CW617N

Sphère : Laiton chromé

Axe : Laiton

Étanchéité : PTFE

Raccordement : Femelle BSP

Pression de service max : 25 bar

Température de service : -20°C / +120°C

Passage intégral

Body: Nickel-plated brass CW617N

Ball: Chromed brass

Stem: Brass

Seal: PTFE

Connection: Female BSP

Maximum working pressure: 25 bar

Working temperature: -20°C / +120°C

Full bore

DN		L (mm)	Kg	Ref.
mm	inch			
8	1/4"	40	0,12	BS1143-0008
10	3/8"	43,8	0,14	BS1143-0010
15	1/2"	47	0,17	BS1143-0015
20	3/4"	53,3	0,23	BS1143-0020
25	1"	65	0,37	BS1143-0025
32	1 1/4"	73,1	0,60	BS1143-0032
40	1 1/2"	80,9	0,75	BS1143-0040
50	2"	98	1,30	BS1143-0050

BS1145

PN16 - ACS

Robinet à boisseau sphérique passage standard femelle BSP - laiton - ACS

Standard bore ball valve female BSP - Brass - ACS



ACS



Corps : Laiton nickelé CW617N

Sphère : Laiton chromé

Axe : Laiton

Étanchéité : PTFE

Raccordement : Femelle BSP

Pression de service max : 16 bar

Température de service : -10°C / +100°C

Passage standard

Body: Nickel-plated brass CW617N

Ball: Chromed brass

Stem: Brass

Seal: PTFE

Connection: Female BSP

Maximum working pressure: 16 bar

Working temperature: -10°C / +100°C

Standard bore

DN		L (mm)	Kg	Ref.
mm	inch			
65	2 1/2"	109	1,8	BS1145-0065
80	3"	129	3	BS1145-0080
100	4"	148	4,55	BS1145-0100



BS1152A | BS1152B

30 bar - ACS

Robinet à boisseau sphérique passage intégral 2 voies femelle BSP - laiton - ACS
2-way full bore ball valve female BSP - Brass - ACS



BS1152A
Poignée plate acier carbone chromé
Carbon steel chromed lever



Corps : Laiton nickelé CW617N
Sphère : Laiton chromé
Axe injectable : Laiton
Étanchéité : PTFE
Raccordement : Femelle BSP
Pression de service max : 30 bar
Température de service : -20°C / +120°C
Passage intégral

Body: Nickel-plated brass CW617N
Ball: Chromed brass
Anti blow out stem: Brass
Seal: PTFE
Connection: Female BSP
Maximum working pressure: 30 bar
Working temperature: -20°C / +120°C
Full bore

ACS en cours / in progress



Remplace | Replace
BS1143 / BS1145

Poignée plate acier carbone chromé Carbon steel chromed lever					
DN		L (mm)	Kg	Ref.	
mm	inch				
8	1/4"	40,6	0,13	BS1152A-02PF0008	
10	3/8"	40,6	0,11	BS1152A-02PF0010	
15	1/2"	47,8	0,17	BS1152A-02PF0015	
20	3/4"	55	0,25	BS1152A-02PF0020	
25	1"	66	0,45	BS1152A-02PF0025	
32	1 1/4"	80	0,61	BS1152A-02PF0032	
40	1 1/2"	91	0,88	BS1152A-02PF0040	
50	2"	106	1,47	BS1152A-02PF0050	
65	2 1/2"	131	2,68	BS1152A-02PF0065	
80	3"	151,5	4,08	BS1152A-02PF0080	
100	4"	168,8	5,84	BS1152A-02PF0100	



BS1152B
Poignée papillon aluminium
Aluminium Butterfly handle



Passage intégral
Full bore

Poignée papillon aluminium Aluminium butterfly handle					
DN		L (mm)	Kg	Ref.	
mm	inch				
8	1/4"	40,6	0,10	BS1152B-02PF0008	
10	3/8"	40,6	0,92	BS1152B-02PF0010	
15	1/2"	47,8	0,14	BS1152B-02PF0015	
20	3/4"	55	0,22	BS1152B-02PF0020	
25	1"	66	0,40	BS1152B-02PF0025	

BS1654

Mâle - Femelle BSP | Male female BSP

Robinet à boisseau sphérique passage intégral mâle - femelle BSP - laiton
Full bore ball valve male female BSP - Brass



Corps : Laiton nickelé CW617N
Sphère : Laiton
Axe : Laiton
Étanchéité : PTFE
Raccordement : Mâle-femelle BSP
Pression de service max : 25 bar
Température de service : -20°C/+120°C

Body: Nickel-plated brass CW617N
Ball: Brass
Stem: Brass
Seal: PTFE
Connection: Male-female BSP
Maximum working pressure: 25 bar
Working temperature: -20°C/+120°C



Passage intégral
Full bore

JUSQU'À ÉPUISEMENT DES STOCKS
WHILE STOCKS LAST

DN		L (mm)	Kg	Ref.	
mm	inch				
8	1/4"	49	0,13	BS1654-0008	
10	3/8"	51	0,12	BS1654-0010	
15	1/2"	54	0,17	BS1654-0015	
20	3/4"	60,3	0,24	BS1654-0020	
25	1"	73,5	0,40	BS1654-0025	
32	1 1/4"	81,8	0,63	BS1654-0032	
40	1 1/2"	90,4	0,78	BS1654-0040	
50	2"	106,5	1,35	BS1654-0050	

BS1653

Mâle - Femelle BSP | Male-female BSP

Robinet à boisseau sphérique passage intégral mâle - femelle BSP - poignée papillon
Full bore ball valve male female BSP - Brass - butterfly handle



Corps : Laiton nickelé
Sphère : Laiton chromé
Axe : Laiton
Étanchéité : PTFE
Raccordement : Mâle-femelle BSP
Pression de service max : 16 bar
Température de service : -20°C/+120°C

Body: Nickel-plated brass
Ball: Chromed brass
Stem: Brass
Seal: PTFE
Connection: Male-female BSP
Maximum working pressure: 16 bar
Working temperature: -20°C/+120°C



Passage intégral
Full bore

JUSQU'À ÉPUISEMENT DES STOCKS
WHILE STOCKS LAST

DN		L (mm)	Kg	Ref.	
mm	inch				
8	1/4"	49	0,12	BS1653-0008	
10	3/8"	48	0,12	BS1653-0010	
15	1/2"	57,5	0,17	BS1653-0015	
20	3/4"	63,5	0,27	BS1653-0020	
25	1"	69	0,48	BS1653-0025	

BS1152C | BS1152D

Mâle - Femelle BSP | Male-female BSP

Robinet à boisseau sphérique passage intégral 2 voies mâle - femelle BSP - laiton - ACS
2-way full bore ball valve male female BSP - Brass - ACS



BS1152C
Poignée plate acier carbone chromé
Carbon steel chromed lever



Corps : Laiton nickelé CW617N
Sphère : Laiton chromé
Axe : Laiton injectable
Étanchéité : PTFE
Raccordement : Male Femelle BSP
Pression de service max : 30 bar
Température de service : -20°C / +120°C
Passage intégral

Body: Nickel-plated brass CW617N
Ball: Chromed brass
Stem: Brass
Seal: PTFE
Connection: Male-female BSP
Maximum working pressure: 30 bar
Working temperature: -20°C / +120°C
Full bore

ACS en cours / in progress



Remplace | Replace
BS1654 / BS1653



BS1152D
Poignée papillon aluminium
Aluminium butterfly handle



Passage intégral
Full bore

Poignée plate acier carbone chromé Carbon steel chromed lever				
DN		L (mm)	Kg	Ref.
mm	inch			
8	1/4"	43,3	0,12	BS1152C-02PF0008
10	3/8"	43,3	0,11	BS1152C-02PF0010
15	1/2"	48,8	0,16	BS1152C-02PF0015
20	3/4"	56	0,24	BS1152C-02PF0020
25	1"	67	0,44	BS1152C-02PF0025
32	1 1/4	80	0,60	BS1152C-02PF0032
40	1 1/2	91	0,86	BS1152C-02PF0040
50	2"	107	1,43	BS1152C-02PF0050

Poignée papillon aluminium Aluminium Butterfly handle				
DN		L (mm)	Kg	Ref.
mm	inch			
8	1/4"	43,3	0,97	BS1152D-02PF0008
10	3/8"	43,3	0,90	BS1152D-02PF0010
15	1/2"	48,8	0,14	BS1152D-02PF0015
20	3/4"	56	0,22	BS1152D-02PF0020
25	1"	67	0,39	BS1152D-02PF0025

BS1162MML

Mâle BSP | Male BSP

Robinet à boisseau sphérique passage intégral mâle BSP - laiton
Full bore ball valve male BSP - Brass



Corps : Laiton nickelé CW617N
Sphère : Laiton
Axe : Laiton
Étanchéité : PTFE
Raccordement : Mâle BSP
Pression de service max : voir tableau
Température de service : -10°C/+120°C

Body: Nickel-plated brass CW617N
Ball: Brass
Stem: Brass
Seal: PTFE
Connection: Male BSP
Maximum working pressure: see chart
Working temperature: -10°C/+120°C



Passage intégral
Full bore

DN		P (bar)	L (mm)	Kg	Ref.
mm	inch				
10	3/8"	30	50,5	0,12	BS1162MML-0010
15	1/2"	30	57	0,17	BS1162MML-0015
20	3/4"	30	66,5	0,24	BS1162MML-0020
25	1"	30	75	0,40	BS1162MML-0025
32	1 1/4	20	90,5	0,63	BS1162MML-0032
40	1 1/2	20	104	0,78	BS1162MML-0040
50	2"	16	122,5	1,35	BS1162MML-0050

BS1143P

Robinet à boisseau sphérique passage standard femme BSP - laiton - avec purge
Standard bore ball valve female BSP - Brass - with drain plug



Corps : Laiton CW617N
Sphère : Laiton
Axe : Laiton
Étanchéité : PTFE
Raccordement : Femelle BSP
Pression de service max : 30 bar
Température de service : -20°C/+120°C
Avec purge papillon

Body: Brass CW617N
Ball: Brass
Stem: Brass
Seal: PTFE
Connection: Female BSP
Maximum working pressure: 30 bar
Working temperature: -20°C/+120°C
With butterfly drain plug

**JUSQU'À ÉPUISEMENT DES STOCKS
WHILE STOCKS LAST**



Passage intégral
Full bore



Avec purge
With drain plug

DN		L (mm)	Kg	Ref.
mm	inch			
15	1/2"	52	0,23	BS1143P-0015
20	3/4"	61	0,32	BS1143P-0020
25	1"	68,5	0,45	BS1143P-0025
32	1 1/4	85,5	0,68	BS1143P-0032
40	1 1/2	95,5	1,00	BS1143P-0040
50	2"	105,5	1,31	BS1143P-0050

BS1152E-02

Femelle BSP | Female BSP

Robinet à boisseau sphérique passage intégral femelle BSP - laiton - avec robinet de purge - ACS
Full bore ball valve female BSP - Brass - with drain plug - ACS



Corps : Laiton nickelé CW617N
Sphère : Laiton chromé
Axe : Laiton
Étanchéité : PTFE
Raccordement : Femelle BSP
Pression de service max : 25 bar
Température de service : -20°C/+120°C
Passage intégral



Remplace | Replace
BS1143P

Body: Nickel-plated brass CW617N
Ball: Chromed brass
Stem: Brass
Seal: PTFE
Connection: Female BSP
Maximum working pressure: 25 bar
Working temperature: -20°C/+120°C
Full bore



Avec purge
With drain plug

ACS en cours / in progress

DN		L (mm)	Kg	Ref.
mm	inch			
15	1/2"	55,5	0,24	BS1152E-02PF0015
20	3/4"	60	0,31	BS1152E-02PF0020
25	1"	72,5	0,46	BS1152E-02PF0025
32	1 1/4	81	0,68	BS1152E-02PF0032
40	1 1/2	93	1,02	BS1152E-02PF0040
50	2"	103	1,31	BS1152E-02PF0050



BS1143R

Avec réhausse | With stem extension

Robinet à boisseau sphérique passage intégral femelle BSP – laiton - avec réhausse
Full bore ball valve female BSP – Brass – with stem extension



Corps : Laiton nickelé CW617N
Sphère : Laiton nickelé
Axe : Laiton
Etanchéité : PTFE
Raccordement : Femelle BSP
Pression de service :
DN3/8" au DN1" : 30 bar
DN1"1/4 au DN1"1/2 : 20 bar
DN2" : 16 bar
Température de service :
-10°C/+120°C

Body: Nickel-plated brass CW617N
Ball: Brass
Stem: Brass
Seal: PTFE
Connection: Female BSP
Working pressure :
DN3/8" to DN1": 30 bar
DN1"1/4 to DN1"1/2: 20 bar
DN2": 16 bar
Working temperature:
-10°C/+120°C

DN		L (mm)	Kg	Ref.
mm	inch			
10	3/8"	44	0,17	BS1143R-0010
15	1/2"	49	0,23	BS1143R-0015
20	3/4"	56	0,30	BS1143R-0020
25	1"	66	0,46	BS1143R-0025
32	1"1/4	76	0,72	BS1143R-0032
40	1"1/2	87	0,97	BS1143R-0040
50	2"	103	1,52	BS1143R-0050



**Avec rehausse pour réseau calorifugé
With stem extension for insulation networks**

BS1160

Laiton dégraissé | Dry cleaned brass

Robinet à boisseau sphérique passage intégral femelle BSP – laiton dégraissé
Full bore ball valve female BSP – dry cleaned Brass



Corps : Laiton nickelé CW617N
Sphère : Laiton nickelé
Axe : Laiton
Etanchéité : PTFE
Raccordement : Femelle BSP
Pression de service :
DN1/4" au DN1" : 40 bar
DN1"1/4 : 32 bar
DN1"1/2 : 30 bar
DN2" : 25 bar
Température de service :
-20°C/+120°C

Body: Nickel-plated brass CW617N
Ball: Brass
Stem: Brass
Seal: PTFE
Connection: Female BSP
Working pressure:
DN1/4" to DN1": 40 bar
DN1"1/4: 32 bar
DN1"1/2: 30 bar
DN2": 25 bar
Working temperature:
-20°C/+120°C

DN		L (mm)	Kg	Ref.
mm	inch			
8	1/4"	46,5	0,14	BS1160-0008
10	3/8"	46,5	0,12	BS1160-0010
15	1/2"	62	0,26	BS1160-0015
20	3/4"	71	0,34	BS1160-0020
25	1"	81,5	0,60	BS1160-0025
32	1"1/4	92	0,87	BS1160-0032
40	1"1/2	102	1,33	BS1160-0040
50	2"	126	1,99	BS1160-0050



**Dégraissé pour application oxygène
Dry cleaned for oxygen application**

BS1161NPT

NPT

Robinet à boisseau sphérique passage intégral femelle NPT – laiton
Full bore ball valve female NPT – Brass



Corps : Laiton nickelé CW617N
Sphère : Laiton nickelé
Axe : Laiton
Etanchéité : PTFE
Raccordement : Femelle NPT
Pression de service : 40 bar
Température de service :
-10°C/+120°C

Body: Nickel-plated brass CW617N
Ball: Brass
Stem: Brass
Seal: PTFE
Connection: Female NPT
Working pressure: 40 bar
Working temperature:
-10°C/+120°C

DN		L (mm)	Kg	Ref.
mm	inch			
8	1/4"	46,5	0,14	BS1161NPT-0008
10	3/8"	46,5	0,12	BS1161NPT-0010
15	1/2"	62	0,26	BS1161NPT-0015
20	3/4"	71	0,34	BS1161NPT-0020
25	1"	81,5	0,60	BS1161NPT-0025

RP1105 | RP1105P

Robinet de puisage à boisseau sphérique mâle BSP – laiton - ACS
Bibcock ball valve male BSP – Brass – ACS



Corps : Laiton nickelé CW617N
Sphère : Laiton chromé
Sièges : PTFE
Raccordement : Mâle BSP
Pression de service max : 16 bar
Température max : 60°C

Body: Nickel-plated brass CW617N
Ball: Chromed brass
Seats: PTFE
Connection: Male BSP
Maximum working pressure: 16 bar
Working temperature: 60°C



**Robinet de puisage
Bibcock ball valve**

Poignée plate acier / Carbon steel lever

DN		L (mm)	Kg	racc. au nez hose coupling	Ref.
mm	inch				
15	1/2"	90	0,30	3/4"x19	RP1105-0015
20	3/4"	102	0,34	3/4"x19	RP1105-0020
25	1"	124	0,38	1"x20,5	RP1105-0025

Poignée papillon / Butterfly handle

DN		L (mm)	Kg	racc. au nez hose coupling	Ref.
mm	inch				
15	1/2"	55	0,17	3/4"x19	RP1105P-0015
20	3/4"	61	0,20	3/4"x19	RP1105P-0020

BS1169FFL | BS1169FFP

Femelle BSP | Female BSP

Robinet à boisseau sphérique passage intégral femelle BSP - laiton - certifié NF

Full bore ball valve female BSP - Brass - NF certified



Corps : Laiton CW617N
Sphère : Laiton chromé, percée afin d'éviter les rétentions de fluide
Axe : Laiton
Etanchéité : PTFE
Raccordement : Femelle BSP
Pression de service max :
 DN1/4" au DN3/4" : 40 bar
 DN1" au DN1"1/4" : 25 bar
 DN1"1/2 au DN2" : 16 bar
Température de service :
 -10°C/+120°C
FFL : Modèle à poignée
FFP : Modèle à manette papillon

Body : Brass CW617N
Ball : Chromed brass, drilled to avoid fluid stagnation
Stem : Brass
Seal : PTFE
Connection : Female BSP
Maximum working pressure:
 DN1/4" to DN3/4": 40 bar
 DN1" to DN1"1/4": 25 bar
 DN1"1/2 to DN2": 16 bar
Working Temperature :
 -10°C/+120°C
FFL : With lever
FFP : With butterfly handle

DN		L (mm)	Kg	Ref.
mm	inch			
8	1/4"	42,5	0,12 0,11	BS1169FFL-0008 BS1169FFP-0008
10	3/8"	42,5	0,11 0,09	BS1169FFL-0010 BS1169FFP-0010
15	1/2"	50,5	0,19 0,16	BS1169FFL-0015 BS1169FFP-0015
20	3/4"	61	0,28 0,25	BS1169FFL-0020 BS1169FFP-0020
25	1"	71	0,48 0,43	BS1169FFL-0025 BS1169FFP-0025
32	1"1/4	83,5	0,73	BS1169FFL-0032
40	1"1/2	93	0,99	BS1169FFL-0040
50	2"	112	1,80	BS1169FFL-0050

BS1169MFL | BS1169MFP

Mâle - Femelle BSP | Male-female BSP

Robinet à boisseau sphérique passage intégral mâle - femelle BSP - laiton - certifié NF

Full bore ball valve male-female BSP - Brass - NF certified



Corps : Laiton CW617N
Sphère : Laiton chromé, percée afin d'éviter les rétentions de fluide
Axe : Laiton
Etanchéité : PTFE
Raccordement : Mâle-femelle BSP
Pression de service max :
 DN1/4" au DN3/4" : 40 bar
 DN1" au DN1"1/4" : 25 bar
 DN1"1/2 au DN2" : 16 bar
Température max : -10°C/+120°C
MFL : Modèle à poignée
MFP : Modèle à manette papillon

Body : Brass CW617N
Ball : Chromed brass, drilled to avoid fluid stagnation
Stem : Brass
Seal : PTFE
Connection : Male-female BSP
Maximum working pressure:
 DN1/4" to DN3/4": 40 bar
 DN1" to DN1"1/4": 25 bar
 DN1"1/2 to DN2": 16 bar
Working temperature: -10°C/+120°C
MFL : With lever
MFP : With butterfly handle

DN		L (mm)	Kg	Ref.
mm	inch			
8	1/4"	49,5	0,12 0,11	BS1169MFL-0008 BS1169MFP-0008
10	3/8"	49,5	0,12 0,10	BS1169MFL-0010 BS1169MFP-0010
15	1/2"	56	0,19 0,16	BS1169MFL-0015 BS1169MFP-0015
20	3/4"	66,5	0,29 0,26	BS1169MFL-0020 BS1169MFP-0020
25	1"	78	0,50 0,45	BS1169MFL-0025 BS1169MFP-0025
32	1"1/4	91	0,76	BS1169MFL-0032
40	1"1/2	102	1,03	BS1169MFL-0040
50	2"	119	1,89	BS1169MFL-0050

BS1169MML | BS1169MMP

Mâle BSP | Male BSP

Robinet à boisseau sphérique passage intégrale mâle BSP - laiton titré - certifié NF

Full bore ball valve male BSP - Brass - NF Certified



Corps : Laiton CW617N
Sphère : Laiton chromé, percée afin d'éviter les rétentions de fluide
Axe : Laiton
Etanchéité : PTFE
Raccordement : Mâle BSP
Pression de service max :
 DN1/4" au DN3/4" : 40 bar
 DN1" au DN1"1/4" : 25 bar
 DN1"1/2 au DN2" : 16 bar
Température max : -5°C/+90°C
MML : Modèle à poignée
MMP : Modèle à manette papillon

Body : Brass CW617N
Ball : Chromed brass drilled to avoid fluid stagnation
Stem : Brass
Seal : PTFE
Connection : Male BSP
Maximum working pressure:
 DN1/4" to DN3/4": 40 bar
 DN1" to DN1"1/4": 25 bar
 DN1"1/2 to DN2": 16 bar
Working temperature: -5°C/+90°C
MML : With lever
MMP : With butterfly handle

DN		L (mm)	Kg	Ref.
mm	inch			
10	3/8"	49,5	0,12 0,10	BS1169MML-0010 BS1169MMP-0010
15	1/2"	55	0,19 0,16	BS1169MML-0015 BS1169MMP-0015
20	3/4"	66	0,28 0,24	BS1169MML-0020 BS1169MMP-0020
25	1"	77,5	0,48 0,43	BS1169MML-0025 BS1169MMP-0025
32	1"1/4	89	0,75	BS1169MML-0032
40	1"1/2	102	1,01	BS1169MML-0040
50	2"	116,5	1,80	BS1169MML-0050

BS1169FFR

Robinet à boisseau sphérique passage intégral femelle BSP - laiton - à réhausse certifié NF

Full bore ball valve female BSP- Brass - with stem extension NF certified



Corps : Laiton CW617N
 Sphère : Laiton chromé, percée afin d'éviter les rétentions de fluide
 Axe : Laiton
 Etanchéité : PTFE
 Raccordement : Femelle BSP
 Pression de service max :
 DN1/4" au DN3/4" : 40 bar
 DN1" au DN1"1/4" : 25 bar
 DN1"1/2 au DN2" : 16 bar
 Température de service : -5°C/+90°C

Body: Brass CW617N
 Ball: Chromed brass, drilled to avoid fluid stagnation
 Stem: Brass
 Seal: PTFE
 Connection: Female BSP
 Maximum working pressure:
 DN1/4" to DN3/4": 40
 DN1" to DN1"1/4": 25
 DN1"1/2 to DN2": 16
 Working temperature: -5°C/+90°C

DN		L (mm)	Kg	Ref.
mm	inch			
15	1/2"	51	0,27	BS1169FFR-0015
20	3/4"	61	0,36	BS1169FFR-0020
25	1"	71	0,56	BS1169FFR-0025
32	1"1/4"	84	0,88	BS1169FFR-0032
40	1"1/2"	93	1,16	BS1169FFR-0040
50	2"	112	1,88	BS1169FFR-0050



Avec réhausse pour réseau calorifugé
With stem extension for insulation networks

**BS1152**

Robinet à boisseau sphérique femelle BSP pour usage gaz - certifié NF

Ball valve female BSP- Brass - for gas use NF certified



Corps : Laiton CW617N
 Sphère : Laiton chromé
 Axe : Laiton
 Etanchéité : PTFE
 Raccordement : Femelle BSP
 Pression de service max : 5 bar
 Température max : -5°C/+60°C
Certificat NF ROB 027-R3

Body: Brass CW617N
 Ball: Chromed brass
 Stem: Brass
 Seal: PTFE
 Connection: Female BSP
 Maximum working pressure: 5 bar
 Max Temperature: -5°C/+60°C
NF ROB 027-R3 Certificate

DN		L (mm)	Kg	Ref.
mm	inch			
15	1/2"	62	0,24	BS1152-0015
20	3/4"	70	0,38	BS1152-0020
25	1"	82	0,62	BS1152-0025
32	1"1/4"	98	1,03	BS1152-0032
40	1"1/2"	109	1,39	BS1152-0040
50	2"	125	2,11	BS1152-0050



Application gaz
Gas application



**ROBINETS À BOISSEAU SPHÉRIQUE À BRIDES
FLANGED BALL VALVES**

BS1240

Robinet à boisseau sphérique passage intégral à brides - laiton

Flanged full bore ball valve - Brass



Corps : Laiton CW617N
Sphère : Laiton chromé
Axe : Laiton
Étanchéité : PTFE
Raccordement : A brides PN10/16
Pression de service max : 10 bar
Température de service : -10°C/+120°C

Body: Brass CW617N
Ball: Chromed brass
Stem: Brass
Seal: PTFE
Connection: PN10/16 flanged
Maximum working pressure: 10 bar
Working temperature: -10°C/+120°C

DN		L (mm)	Kg	Ref.
mm	inch			
15	1/2"	65	1,40	BS1240-0015
20	3/4"	80	1,80	BS1240-0020
25	1"	85	2,50	BS1240-0025
32	1"1/4	100	3,62	BS1240-0032
40	1"1/2	110	4,76	BS1240-0040
50	2"	125	6,50	BS1240-0050
65	2"1/2	140	8,90	BS1240-0065
80	3"	150	11,85	BS1240-0080
100	4"	170	15,60	BS1240-0100

BS3242

Fonte grise | Cast iron

Robinet à boisseau sphérique passage intégral à brides - fonte - écartement EN 558 série 14 (DN15 + DN150) | série 27 (DN15 à DN100 + DN200)

Flanged full bore ball valve - Cast iron - EN558 série 14 (DN15 + DN150) | Serie 27 (DN15 to DN100 + DN200)



Corps : Fonte grise ENGJL-250 (GG25)
Sphère : ASTM A182 F303
Pleine jusqu'au DN25
Creuse au-delà du DN25
Axe : Inox 304
Étanchéité : PTFE
Raccordement : A brides PN 10/16 - (DN200 PN16)
Pression de service max : 16 bar
Température de service : -10°C/+120°C
Platine ISO 5211
Ne convient pas pour la vapeur ni l'air comprimé

Body: ENGJL-250 (GG25) Cast iron
Ball: ASTM A182 F304
Solid Stainless steel ball up to DN25
Hollow ball beyond DN25
Stem: Stainless steel 304
Seal: PTFE
Connection: Flanged PN10/16 - (DN 200 PN16)
Maximum working pressure: 16 bar
Working temperature: -10°C/+120°C
ISO 5211 mounting plate
Not suitable for steam or compressed air

DN		L (mm)	Kg	Ref.
mm	inch			
15	1/2"	115	2,12	BS3242-0015
20	3/4"	120	2,72	BS3242-0020
25	1"	125	3,62	BS3242-0025
32	1"1/4	130	5,32	BS3242-0032
40	1"1/2	140	6,90	BS3242-0040
50	2"	150	9,00	BS3242-0050
65	2"1/2	170	11,68	BS3242-0065
80	3"	180	14,68	BS3242-0080
100	4"	190	20,23	BS3242-0100
125	5"	200	33,73	BS3242-0125
150	6"	210	49,77	BS3242-0150
200	8"	400	81,77	BS3242-0200



**ROBINETS À BOISSEAU SPHÉRIQUE LAITON 3 VOIES
3-WAY BRASS BALL VALVES**

BS1166 | BS1167

Robinet à boisseau sphérique modèle 3 voies femelle BSP

3-way ball valve female BSP



BS1166 : Passage en L / L port
BS1167 : Passage en T / T port

Corps : Laiton CW617N
Sphère : Laiton chromé
Axe : Laiton
Étanchéité : PTFE
Raccordement : Femelle BSP
Pression de service max : 16 bar
Pression différentielle : 5 bar maxi
Température de service : -10°C/+120°C



**3 voies
3-way**

Body: Brass CW617N
Ball: Chromed brass
Stem: Brass
Seal: PTFE
Connection: Female BSP
Maximum working pressure: 16 bar
Differential pressure: 5 bar maxi
Working temperature: -10°C/+120°C

DN		L (mm)	Kg	Ref.
mm	inch			
8	1/4"	81	0,69	BS1166-0008 BS1167-0008
10	3/8"	81	0,65	BS1166-0010 BS1167-0010
15	1/2"	82	0,66	BS1166-0015 BS1167-0015
20	3/4"	90,5	0,86	BS1166-0020 BS1167-0020
25	1"	105	1,41	BS1166-0025 BS1167-0025
32	1"1/4	116	1,89	BS1166-0032 BS1167-0032
40	1"1/2	140	3,61	BS1166-0040 BS1167-0040
50	2"	164	5,24	BS1166-0050 BS1167-0050



ACIER | STEEL



ROBINETS À BOISSEAU SPHÉRIQUE ACIER TARAUDÉ STEEL THREADED BALL VALVES

BS5179

Acier | Steel

Robinet à boisseau sphérique passage intégral femelle BSP - 2 pièces acier

2-piece full bore ball valve female BSP - Steel



Corps : ASTM A216 WCB
Sphère : ASTM A351 CF8M
Axe : ASTM A 182 F304
Étanchéité : PTFE chargé 3% verre
Raccordement : Femelle BSP
Pression de service :
DN1/4" au DN3/4" : 63 bar
DN1" au DN1 1/4" : 50 bar
DN1 1/2" au DN2" : 40 bar
DN2 1/2" au DN3" : 25 bar
Température de service :
-20°C/+180°C
ATEX : Groupe II, catégorie 2G/2D, zones 1 et 21, zones 2 et 22.

Body: ASTM A216 WCB
Ball: ASTM A351 CF8M
Stem: ASTM A 182 F304
Seal: 3% glass reinforced PTFE
Connection: female BSP
Working pressure:
DN1/4" to DN3/4": 63 bar
DN1" to DN1 1/4": 50 bar
DN1 1/2" to DN2": 40 bar
DN2 1/2" to DN3": 25 bar
Working temperature:
-20°C/+180°C
ATEX : Group II, cat. 2G/2D zone 1 & 21, zone 2 & 22.

DN		L (mm)	Kg	Ref.
mm	inch			
8	1/4"	50	0,27	BS5179-0008
10	3/8"	60	0,26	BS5179-0010
15	1/2"	75	0,32	BS5179-0015
20	3/4"	80	0,42	BS5179-0020
25	1"	90	0,67	BS5179-0025
32	1 1/4"	110	1,12	BS5179-0032
40	1 1/2"	120	1,73	BS5179-0040
50	2"	140	2,78	BS5179-0050
65	2 1/2"	185	5,78	BS5179-0065
80	3"	205	8,38	BS5179-0080



Passage intégral
Poignée cadenassable
Full bore
Lockable handle

BS5190

Robinet à boisseau sphérique haute pression passage réduit femelle BSP - acier

Reduced bore ball valve female BSP - Steel - high pressure



Corps : Acier 1.0737 galvanisé
Sphère : Acier 1.0737 chromé
Siège : POM
Raccordement : Femelle BSP
Pression de service :
DN1/4" au DN1/2" : 500 bar
DN3/4" au DN2" : 315 bar
Température de service :
-10°C/+100°C
ATEX : Groupe II, catégorie 2G/2D, zones 1 et 21, zones 2 et 22.

Body: Steel 1.0737 galvanized
Ball: Steel 1.0737 chromed
Seat: POM
Connection: Female BSP
Working pressure:
DN1/4" to DN1/2": 500 bar
DN3/4" to DN2": 315 bar
Working temperature:
-10°C/+100°C
ATEX : Group II, cat. 2G/2D, zone 1 & 21, zone 2 & 22.

DN		L (mm)	Kg	Ref.
mm	inch			
8	1/4"	71	0,49	BS5190-0008
10	3/8"	73	0,64	BS5190-0010
15	1/2"	83	0,76	BS5190-0015
20	3/4"	95	1,44	BS5190-0020
25	1"	112	2,22	BS5190-0025
32	1 1/4"	120	2,27	BS5190-0032
40	1 1/2"	131	7,39	BS5190-0040
50	2"	140	9,05	BS5190-0050



Haute pression
High pressure



ROBINETS À BOISSEAU SPHÉRIQUE ACIER 3 PIÈCES
3-PIECE STEEL BALL VALVES

BS5379BSP | BS5379BW | BS5379SW | BS5379NPT

Robinet à boisseau sphérique passage intégral à poignée - 3 pièces acier
3-piece full bore ball valve with lever - Steel



- BS5379BSP** : Femelle BSP / Female BSP
- BS5379BW** : A souder en bout / Butt welding connection
- BS5379SW** : A souder par emboîtement / Socket welding connection
- BS5379NPT** : Femelle NPT / Female NPT

Corps : ASTM A216 WCB
Sphère : ASTM A 182 F304
Axe : ASTM A 182 F304
Étanchéité : PTFE chargé 15% verre
Pression de service :
DN1/4" au DN3/4" : 63 bar
DN1" au DN2" : 40 bar
DN2"1/2 au DN4" : 25 bar
Température de service : -20°C/+180°C

Body: ASTM A216 WCB
Ball: ASTM A 182 F304
Stem: ASTM A 182 F304
Seal: 15% glass reinforced PTFE
Working pressure:
DN1/4" to DN3/4": 63 bar
DN1" to 2": DN40 bar
DN2"1/2 to DN4": 25 bar
Working temperature: -20°C/+180°C



Poignée cadenasable
Lockable handle

DN		L (mm)	Kg	Ref.
mm	inch			
8	1/4"	59	0,30	BS5379BSP-0008
				BS5379BW-0008
				BS5379SW-0008
				BS5379NPT-0008
10	3/8"	59	0,30	BS5379BSP-0010
				BS5379BW-0010
				BS5379SW-0010
				BS5379NPT-0010
15	1/2"	63,3	0,45	BS5379BSP-0015
				BS5379BW-0015
				BS5379SW-0015
				BS5379NPT-0015
20	3/4"	70,60	0,60	BS5379BSP-0020
				BS5379BW-0020
				BS5379SW-0020
				BS5379NPT-0020
25	1"	82	0,86	BS5379BSP-0025
				BS5379BW-0025
				BS5379SW-0025
				BS5379NPT-0025
32	1"1/4	97	1,32	BS5379BSP-0032
				BS5379BW-0032
				BS5379SW-0032
				BS5379NPT-0032
40	1"1/2	109	2,03	BS5379BSP-0040
				BS5379BW-0040
				BS5379SW-0040
				BS5379NPT-0040
50	2"	124,6	3,19	BS5379BSP-0050
				BS5379BW-0050
				BS5379SW-0050
				BS5379NPT-0050
65	2"1/2	162	7,06	BS5379BSP-0065
				BS5379BW-0065
				BS5379SW-0065
				BS5379NPT-0065
80	3"	175	10,70	BS5379BSP-0080
				BS5379BW-0080
				BS5379SW-0080
				BS5379NPT-0080
100	4"	216	20,95	BS5379BSP-0100
				BS5379BW-0100
				BS5379SW-0100
				BS5379NPT-0100

BS5379I-BSP | BS5379I-BW | BS5379I-SW

Robinet à boisseau sphérique passage intégral avec platine ISO - 3 pièces acier
3-piece full bore ball valve with ISO mounting plate - Steel



Platine ISO
ISO mounting plate



- BS5379I-BSP** : Femelle BSP / Female BSP
- BS5379I-BW** : A souder en bout / Butt welding connection
- BS5379I-SW** : A souder par emboîtement / Socket welding connection

Corps : ASTM A216 WCB
Sphère : ASTM A351 CF8M
Axe : ASTM A182 F316
Étanchéité : PTFE + inox ASTM A182 F316
Pression de service :
DN1/4" au DN2" : 63 bar
DN2"1/2 au DN4" : 40 bar
Température de service : -20°C/+220°C
Platine ISO 5211

Body: ASTM A216 WCB
Ball: ASTM A351 CF8M
Stem: ASTM A182 F316
Seal: PTFE + Stainless steel A182 F316
Working pressure:
DN1/4" to DN2": 63 bar
DN2"1/2 to DN4": 40 bar
Working temperature: -20°C/+220°C
ISO 5211 mounting plate



Poignée cadenasable
Lockable handle

DN		L (mm)	Kg	Ref.
mm	inch			
8	1/4"	63,50	0,64	BS5379I-BSP-0008
				BS5379I-BW-0008
				BS5379I-SW-0008
10	3/8"	63,50	0,62	BS5379I-BSP-0010
				BS5379I-BW-0010
				BS5379I-SW-0010
15	1/2"	63,50	0,58	BS5379I-BSP-0015
				BS5379I-BW-0015
				BS5379I-SW-0015
20	3/4"	75,50	0,75	BS5379I-BSP-0020
				BS5379I-BW-0020
				BS5379I-SW-0020
25	1"	81	1,03	BS5379I-BSP-0025
				BS5379I-BW-0025
				BS5379I-SW-0025
32	1"1/4	94,50	1,62	BS5379I-BSP-0032
				BS5379I-BW-0032
				BS5379I-SW-0032
40	1"1/2	108	2,50	BS5379I-BSP-0040
				BS5379I-BW-0040
				BS5379I-SW-0040
50	2"	121,50	3,70	BS5379I-BSP-0050
				BS5379I-BW-0050
				BS5379I-SW-0050
65	2"1/2	157,50	7,80	BS5379I-BSP-0065
				BS5379I-BW-0065
				BS5379I-SW-0065
80	3"	190	11,30	BS5379I-BSP-0080
				BS5379I-BW-0080
				BS5379I-SW-0080
100	4"	225	22	BS5379I-BSP-0100
				BS5379I-BW-0100
				BS5379I-SW-0100



PRODUITS ASSOCIÉS | RELATED PRODUCTS

Motorisation électrique et pneumatique | Electric and pneumatic actuator

N24 | N04

Motorisation électrique TEA pour BS5379I
TEA electric actuator for BS5379I



Moteur équipé de :
- 2 contacts fin de course
- 1 résistance de chauffe
Commande manuelle de secours
Indicateur visuel de position
ΔP de calcul indicatif : 10 bar

Actuator equipped:
- 2 limit switches
- 1 heating resistor
Emergency handwheel
Opening indicator
ΔP of indicative calculation: 10 bar

Protection IP67
IP67 protection



ATEX sur demande / ATEX on request

DN		Moteur électrique TECOFI TECOFI electric actuator MONO 230V/50/60Hz		Moteur électrique TECOFI TECOFI electric actuator TRI 400V/50/60Hz	
mm	inch	Type	Ref.	Type	Ref.
8	1/4"	TEA-05-N24	300200148	TEA-05-N04	300200142
10	3/8"	TEA-05-N24	300200148	TEA-05-N04	300200142
15	1/2"	TEA-05-N24	300200148	TEA-05-N04	300200142
20	3/4"	TEA-05-N24	300200148	TEA-05-N04	300200142
25	1"	TEA-05-N24	300200148	TEA-05-N04	300200142
32	1 1/4"	TEA-05-N24	300200148	TEA-05-N04	300200142
40	1 1/2"	TEA-05-N24	300200149	TEA-05-N04	300200143
50	2"	TEA-10-N24	300200150	TEA-10-N04	300200144
65	2 1/2"	TEA-10-N24	300200151	TEA-10-N04	300200145
80	3"	TEA-20-N24	300200152	TEA-20-N04	300200146
100	4"	TEA-40-N24	300200153	TEA-40-N04	300200147

N03 | N07

Motorisation pneumatique TDA | TSR pour BS5379I
TDA | TSR pneumatic actuator for BS5379I



Construction : Aluminium
Pression de service : 6 bar (air lubrifié)
Butées réglables
ΔP de calcul indicatif : 10 bar

Construction: Aluminium
Working pressure: 6 bar (air lubricated)
Stop bolt retaining nut
ΔP of indicative calculation: 10 bar



ATEX sur demande / ATEX on request

DN		Double effet Double-acting		Simple effet Single-acting	
mm	inch	Type	Ref.	Type	Ref.
8	1/4"	TDA-052	300200130	TSR-063	300200137
10	3/8"	TDA-052	300200130	TSR-063	300200137
15	1/2"	TDA-052	300200130	TSR-063	300200137
20	3/4"	TDA-052	300200131	TSR-083	300200138
25	1"	TDA-052	300200132	TSR-083	300200138
32	1 1/4"	TDA-063	300200132	TSR-083	300200138
40	1 1/2"	TDA-063	300200133	TSR-105	300200139
50	2"	TDA-083	300200134	TSR-105	300200139
65	2 1/2"	TDA-092	300200135	TSR-125	300200140
80	3"	TDA-092	300200135	TSR-125	300200140
100	4"	TDA-125	300200136	TSR-160	300200141



Retrouvez nos options et accessoires pour vérin pneumatique TECOFI page 57 à 64 (électropositionneurs, boîtiers fin de course, filtres, positionneurs).

Find all options and accessories p.57 to 64 for pneumatic actuator (solenoid valve, limit switch box, filters, positioners).

BS5378BSP | BS5378BW | BS5378SW | BS5378NPT

Robinet à boisseau sphérique 3 pièces avec platine ISO - Sécurité feu - haute température - acier
3-piece ball valve with ISO mounting plate and fire safe - High temperature - Steel



Poignée cadénassable
Lockable handle

Sécurité feu API 607
Fire safe API 607



BS5378BSP : Femelle BSP / Female BSP
BS5378BW : A souder en bout / Butt welding connection
BS5378SW : A souder par emboîtement / Socket welding connection
BS5378NPT : Femelle NPT / Female NPT

Corps : ASTM A216 WCB
Sphère : ASTM A351 CF8M
Axe : ASTM A182 F316
Etanchéité : PTFE renforcé 15% graphoil
Pression de service :
DN1/4" au DN1" : 140 bar
DN1"1/4 au DN2" : 100 bar
Température de service : -20°C/+218°C
Platine ISO 5211
ATEX : Groupe II, catégorie 2G/2D zones 1 et 21, zones 2 et 22.

Body: ASTM A216 WCB
Ball: ASTM A351 CF8M
Stem: ASTM A182 F316
Seal: PTFE reinforced 15% graphoil
Working pressure:
DN1/4" to DN1": 140 bar
DN1"1/4 to DN2": 100 bar
Working temperature: -20°C/+218°C
ISO 5211 mounting plate
ATEX: Group II, cat 2G/2D zone 1 & 21, zone 2 & 22.

DN		L (mm)	Kg	Ref.
mm	inch			
8	1/4"	64,8	0,74	BS5378BSP-0008 BS5378BW-0008 BS5378SW-0008 BS5378NPT-0008 BS5378BSP-0010 BS5378BW-0010 BS5378SW-0010 BS5378NPT-0010
10	3/8"	64,8	0,72	BS5378BSP-0015 BS5378BW-0015 BS5378SW-0015 BS5378NPT-0015 BS5378BSP-0020 BS5378BW-0020 BS5378SW-0020 BS5378NPT-0020
15	1/2"	72,5	0,72	BS5378BSP-0025 BS5378BW-0025 BS5378SW-0025 BS5378NPT-0025 BS5378BSP-0032 BS5378BW-0032 BS5378SW-0032 BS5378NPT-0032
20	3/4"	85,4	0,85	BS5378BSP-0040 BS5378BW-0040 BS5378SW-0040 BS5378NPT-0040 BS5378BSP-0050 BS5378BW-0050 BS5378SW-0050 BS5378NPT-0050
25	1"	105,3	1,35	
32	1"1/4	111	2,78	
40	1"1/2	127,3	4,08	
50	2"	145	6,74	



ROBINETS À BOISSEAU SPHÉRIQUE ACIER À BRIDES
FLANGED STEEL BALL VALVES

BS5261

2 pièces | Split body PN16/40

Robinet à boisseau sphérique 2 pièces - à brides - acier - PN16/40
Flanged split-body ball valve - Steel - PN16/40



Poignée cadénassable
Lockable handle

Sécurité feu API 607
Fire safe API 607



Corps : Acier EN 1.0619
Sphère : Inox EN 1.4408
Pleine jusqu'au DN100
Creuse du DN125 au DN200
Axe : Inox ASTM A276 316
Etanchéité : PTFE chargé 15% verre
Raccordement : A brides PN40 jusqu'au DN 50 - PN16 à partir du DN 65
Pression de service max :
DN15 au DN50 : 40 bar
DN65 au DN200 : 16 bar
(vapeur maxi 11 bar)
Température de service : -20°C/+200°C
Platine ISO 5211
ATEX : Groupe II, catégorie 2G/2D zones 1 et 21, zones 2 et 22

Body: Acier EN 1.0619
Ball: Stainless steel EN 1.4408
Solid ball up to DN100
Hollow ball beyond DN100
Stem: Stainless steel ASTM A276 316
Seal: 15% glass reinforced PTFE
Connection: PN40 flanged until DN50 - PN16 from DN 65
Maximum working pressure:
DN15 to DN50: 40 bar
DN65 to DN200: 16 bar
(steam maxi 11 bar)
Working temperature: -20°C/+200°C
ISO 5211 mounting plate
ATEX: Group II, cat. 2G/2D zone 1 & 21, zone 2 & 22

DN		L (mm)	Kg	Ref.
mm	inch			
15	1/2"	115	2,30	BS5261-0015
20	3/4"	120	3,00	BS5261-0020
25	1"	125	4,00	BS5261-0025
32	1"1/4	130	5,50	BS5261-0032
40	1"1/2	140	7,00	BS5261-0040
50	2"	150	9,30	BS5261-0050
65	2"1/2	170	14,40	BS5261-0065
80	3"	180	17,50	BS5261-0080
100	4"	190	23,30	BS5261-0100
125	5"	325	36,70	BS5261-0125
150	6"	350	52,00	BS5261-0150
200	8"	400	78,00	BS5261-0200

BSA5241

2 pièces | Split-body PN20 ANSI 150

Robinet à boisseau sphérique ISO PN20 ANSI 150 RF - 2 pièces - à brides - acier
 Flanged split-body ball valve ISO ANSI PN20 class 150 lbs - Steel

Option : ASA 300 sur demande / ASA 300 on request



Corps : ASTM A216 WCB
 Sphère : ASTM A351 CF8M
 Axe : ASTM A276 316
 Etanchéité : PTFE chargé 15% verre
 Raccordement : A brides ISO PN20 / ANSI 150 RF
 Pression de service max : 20 bar
 (vapeur 11 bar maxi)
 Température de service : -20°C/+200°C
 Platine ISO 5211
 ATEX : Zones 1 et 21 / Zones 2 et 22

DN		L (mm)	Kg	Ref.
mm	inch			
15	1/2"	108	1,58	BSA5241-0015
20	3/4"	117	2,04	BSA5241-0020
25	1"	127	3,18	BSA5241-0025
32	1 1/4"	140	4,48	BSA5241-0032
40	1 1/2"	165	6,00	BSA5241-0040
50	2"	178	8,51	BSA5241-0050
65	2 1/2"	190	14,46	BSA5241-0065
80	3"	203	17,60	BSA5241-0080
100	4"	229	26,70	BSA5241-0100



Poignée cadenassable
 Lockable handle

Sécurité feu API 607
 Fire safe API 607

Body: ASTM A216 WCB
 Ball: ASTM A351 CF8M
 Stem: ASTM A276 316
 Seal: 15% glass reinforced PTFE
 Connection: ISO PN20 / ANSI 150 RF flanged
 Maximum working pressure: 20 bar
 (steam maxi 11 bar)
 Working temperature: -20°C/+200°C
 ISO 5211 mounting plate
 ATEX: Zone 1 & 21 / Zone 2 & 22

BS5260

3 pièces | 3-piece PN40

Robinet à boisseau sphérique passage intégral 3 pièces - à brides - acier - PN40
 3-piece full bore flanged ball valve - Steel - PN40



Corps : ASTM A216 WCB
 Sphère : Inox AISI 304
 Axe : Inox AISI 304
 Etanchéité : PTFE chargé 15% verre
 Raccordement : À brides PN40
 Pression de service : 40 bar
 Température de service : -20°C/+180°C

DN		L (mm)	Kg	Ref.
mm	inch			
15	1/2"	130	2,10	BS5260-0015
20	3/4"	150	2,80	BS5260-0020
25	1"	160	3,64	BS5260-0025
32	1 1/4"	180	5,50	BS5260-0032
40	1 1/2"	200	7,30	BS5260-0040
50	2"	230	10,00	BS5260-0050
65	2 1/2"	290	19,50	BS5260-0065
80	3"	310	25,10	BS5260-0080
100	4"	350	36,30	BS5260-0100



Poignée cadenassable
 Lockable handle

Body: ASTM A216 WCB
 Ball: Stainless steel AISI 304
 Stem: Stainless steel AISI 304
 Seal: 15% glass reinforced PTFE
 Connection: Flanged PN40
 Working pressure: 40 bar
 Working temperature: -20°C/+180°C



ROBINETS BOISSEAU SPHÉRIQUE ACIER 3 VOIES
 3-WAY STEEL BALL VALVES

BS5241L | BS5241T

Acier | Steel

Robinet à boisseau sphérique 3 voies - à brides - acier
 3-way flanged ball valve - Steel



BS5241L : Lumière en L / L port
 BS5241T : Lumière en T / T port

Corps : Acier EN 1.0619
 Sphère : ASTM A351 CF8
 Axe : Inox AISI 304
 Etanchéité : PTFE chargé 15% verre
 Raccordement : A brides PN10/16
 Pression de service max : 16 bar
 Température de service : -20°C/+150°C
 Platine ISO 5211
 ATEX : Groupe II, catégorie 2G/2D zones 1 et 21, zones 2 et 22

DN		L (mm)	Kg	Ref.
mm	inch			
50	2"	253	19,00	BS5241L-0050
65	2 1/2"	278	23,75	BS5241L-0065
80	3"	292,2	34,50	BS5241L-0080
100	4"	360	67,40	BS5241L-0100
125	5"	416	95,00	BS5241L-0125
150	6"	473	124,00	BS5241L-0150



Levier cadenassable
 Lockable lever

Body: Steel EN 1.0619
 Ball: ASTM A351 CF8
 Stem: Inox AISI 304
 Seal: 15% glass reinforced PTFE
 Connection: PN10/16 flanged
 Maximum working pressure: 16 bar
 Working temperature: -20°C/+150°C
 ISO 5211 mounting plate
 ATEX: Groupe II, cat. 2G/2D zone 1 & 21, zone 2 & 22

DN		L (mm)	Kg	Ref.
mm	inch			
50	2"	253	19,00	BS5241T-0050
65	2 1/2"	278	23,75	BS5241T-0065
80	3"	292,2	34,50	BS5241T-0080
100	4"	360	61,80	BS5241T-0100
125	5"	416	95,00	BS5241T-0125
150	6"	473	127,00	BS5241T-0150

INOX | STAINLESS STEEL



ROBINETS BOISSEAU SPHÉRIQUE INOX TARAUDÉ STAINLESS STEEL THREADED BALL VALVES

BS6175BSP | BS6175NPT

Inox | Stainless Steel

Robinet à boisseau sphérique passage intégral 2 pièces femelle BSP - Inox
Split-body full bore ball valve female BSP - Stainless steel



BS6175BSP : Femelle BSP / Female BSP
BS6175NPT : Femelle NPT / Female NPT

Corps : ASTM A351 CF8M
Sphère : ASTM A351 CF8M
Axe : ASTM A 182 F316
Etanchéité : PTFE agrément FDA conforme à la norme FDA n° 21 CFR 177.1550
Raccordement : Femelle BSP ou NPT
Pression de service max :
DN1/4" au DN3/4" : 63 bar
DN1" au DN1 1/4" : 50 bar
DN1 1/2 au DN2" : 40 bar
DN2 1/2 au DN3" : 25 bar
Température de service : -20°C/+200°C

Body: ASTM A351 CF8M
Ball: ASTM A351 CF8M
Stem: ASTM A 182 F316
Seal: FDA PTFE
Compliant with FDA n° 21 CFR 177.1550
Connection: Female BSP or NPT
Working pressure:
DN1/4" to DN3/4": 63 bar
DN1" to DN1 1/4": 50 bar
DN1 1/2 to DN2": 40 bar
DN2 1/2 to DN3": 25 bar
Working temperature: -20°C/+200°C



Joint FDA
(agrément alimentaire)
FDA joint
(Food Drug Administration)



Poignée cadénassable
Lockable handle

DN		L (mm)	Kg	BSP	NPT
mm	inch			Ref.	Ref.
8	1/4"	46,8	0,18	BS6175BSP-0008	BS6175NPT-0008
10	3/8"	48,5	0,19	BS6175BSP-0010	BS6175NPT-0010
15	1/2"	58	0,26	BS6175BSP-0015	BS6175NPT-0015
20	3/4"	65,7	0,40	BS6175BSP-0020	BS6175NPT-0020
25	1"	77	0,59	BS6175BSP-0025	BS6175NPT-0025
32	1 1/4"	90	1,00	BS6175BSP-0032	BS6175NPT-0032
40	1 1/2"	98	1,32	BS6175BSP-0040	BS6175NPT-0040
50	2"	121	2,46	BS6175BSP-0050	BS6175NPT-0050
65	2 1/2"	145	4,83	BS6175BSP-0065	BS6175NPT-0065
80	3"	166	7,45	BS6175BSP-0080	BS6175NPT-0080

BS6162

Robinet à boisseau sphérique passage réduit monobloc - femelle BSP - Inox
1-piece body reduced bore ball valve - female BSP - Stainless steel



Monobloc
1-piece body



Corps : Inox CF8M
Sphère : Inox 316
Axe : Inox 316
Siège : PTFE chargé 15% verre
Raccordement : Femelle BSP
Pression de service : 40 bar
Température de service : -20°C/+180°C

Body: Stainless steel CF8M
Ball: Stainless steel 316
Stem: Stainless steel 316
Seat: 15% glass reinforced PTFE
Connection: Female BSP
Working pressure: 40 bar
Working temperature: -20°C/+180°C



Poignée cadénassable
Lockable handle

DN		L (mm)	Kg	Ref.
mm	inch			
8	1/4"	39	0,10	BS6162-0008
10	3/8"	44	0,10	BS6162-0010
15	1/2"	55	0,11	BS6162-0015
20	3/4"	59	0,25	BS6162-0020
25	1"	69	0,41	BS6162-0025
32	1 1/4"	77	0,61	BS6162-0032
40	1 1/2"	81	0,75	BS6162-0040
50	2"	97	1,28	BS6162-0050

BS6571

Mâle-femelle BSP | Male-female BSP

Robinet à boisseau sphérique passage intégral mâle-femelle BSP - modèle 2 pièces Inox
2-piece full bore ball valve - male-female BSP - Stainless steel



Corps : ASTM A351 CF8M
Sphère : Inox 316
Axe : Inox 316
Etanchéité : PTFE chargé 3% verre
Raccordement : Mâle-femelle BSP
Pression de service max :
DN1/4" au DN3/4" : 63 bar
DN1" au DN1 1/4" : 50 bar
DN1 1/2 au DN2" : 40 bar
Température de service : -10°C/+180°C

Body: ASTM A351 CF8M
Ball: Stainless steel 316
Stem: Stainless steel 316
Seal: 3% glass reinforced PTFE
Connection: Male-female BSP
Working pressure:
DN1/4" to DN3/4": 63 bar
DN1" to DN1 1/4": 50 bar
DN1 1/2 to DN2": 40 bar
Working temperature: -10°C/+180°C



Poignée cadénassable
Lockable handle

DN		L (mm)	Kg	Ref.
mm	inch			
8	1/4"	62,5	0,275	BS6571-0008
10	3/8"	63,5	0,270	BS6571-0010
15	1/2"	74	0,380	BS6571-0015
20	3/4"	82	0,550	BS6571-0020
25	1"	98,5	0,810	BS6571-0025
32	1 1/4"	112	1,320	BS6571-0032
40	1 1/2"	126	1,980	BS6571-0040
50	2"	151	3,260	BS6571-0050



BSM6179 | BSM6779

Robinet à boisseau sphérique 2 pièces femelle BSP / NPT - Inox
Split-body ball valve female BSP / NPT - Stainless steel



**BIENTÔT DISPONIBLE - AVRIL 2021
COMING SOON - APRIL 2021**



BSM6179 : Femelle BSP / female BSP
BSM6779 : Femelle NPT / female NPT

Corps : Acier inoxydable A351 CF8M
Sphère : Acier inoxydable AISI 316
Axe : Acier inoxydable AISI 316
Étanchéité : PTFE chargé 15% verre
Pression de service max : 63 bar
Température de service : -25°C/+180°C
Platine ISO 5211
ATEX : II 2 GD C T2

Body: Stainless steel A351 CF8M
Ball: Stainless steel AISI 316
Stem: Stainless steel AISI 316
Seal: 15% glass reinforced PTFE
Maximum working pressure: 63 bar
Working temperature: -25°C/+180°C
ISO 5211 mounting plate
ATEX: II 2 GD C T2



**Poignée cadenassable
Lockable handle**

A levier platine ISO Lever with ISO mounting plate				
mm	inch	L (mm)	Kg	Ref.
08	1/4"	56	0,37	BSM6179-02PV0008 BSM6779-02PV0008
10	3/8"	56	0,35	BSM6179-02PV0010 BSM6779-02PV0010
15	1/2"	57	0,37	BSM6179-02PV0015 BSM6779-02PV0015
20	3/4"	64	0,49	BSM6179-02PV0020 BSM6779-02PV0020
25	1"	77	0,74	BSM6179-02PV0025 BSM6779-02PV0025
32	1"1/4	90	1,18	BSM6179-02PV0032 BSM6779-02PV0032
40	1"1/2	105	1,94	BSM6179-02PV0040 BSM6779-02PV0040
50	2"	125	2,90	BSM6179-02PV0050 BSM6779-02PV0050
65	2"1/2	153	5,77	BSM6179-02PV0065 BSM6779-02PV0065
80	3"	172	8,45	BSM6179-02PV0080 BSM6779-02PV0080
100	4"	221	15,60	BSM6179-02PV0100 BSM6779-02PV0100

BSM6179-N03 | BSM6179-N07 | BSM6779-N03 | BSM6779-N07

Robinet à boisseau sphérique 2 pièces femelle BSP / NPT - Inox - à vérin pneumatique
Split-body ball valve female BSP / NPT - Stainless steel - with pneumatic actuator



BSM6179 : Femelle BSP / Female BSP
BSM6779 : Femelle NPT / Female NPT

Corps : Acier inoxydable A351 CF8M
Sphère : Acier inoxydable AISI 316
Axe : Acier inoxydable AISI 316
Étanchéité : PTFE chargé 15% verre
Pression de service max : 63 bar
Température de service : -25°C/+180°C
ΔP de calcul maxi : 10 bar

Body: Stainless steel A351 CF8M
Ball: Stainless steel AISI 316
Stem: Stainless steel AISI 316
Seal: 15% glass reinforced PTFE
Maximum working pressure: 63 bar
Working temperature: -25°C/+180°C
ΔP of max calculation: 10 bar



ATEX sur demande / ATEX on request



					Vérin pneumatique Pneumatic actuator	
					Double effet / Double-acting	Simple effet / Single-acting
DN		L (mm)	Kg	Ref.	Ref.	Ref.
mm	inch					
08	1/4"	56	1,75	BSM6179-N03PV0008 BSM6779-N03PV0008	BSM6179-N07PV0008 BSM6779-N07PV0008	
10	3/8"	56	1,72	BSM6179-N03PV0010 BSM6779-N03PV0010	BSM6179-N07PV0010 BSM6779-N07PV0010	
15	1/2"	57	1,75	BSM6179-N03PV0015 BSM6779-N03PV0015	BSM6179-N07PV0015 BSM6779-N07PV0015	
20	3/4"	64	1,87	BSM6179-N03PV0020 BSM6779-N03PV0020	BSM6179-N07PV0020 BSM6779-N07PV0020	
25	1"	77	2,12	BSM6179-N03PV0025 BSM6779-N03PV0025	BSM6179-N07PV0025 BSM6779-N07PV0025	
32	1"1/4	90	2,56	BSM6179-N03PV0032 BSM6779-N03PV0032	BSM6179-N07PV0032 BSM6779-N07PV0032	
40	1"1/2	105	3,97	BSM6179-N03PV0040 BSM6779-N03PV0040	BSM6179-N07PV0040 BSM6779-N07PV0040	
50	2"	125	4,93	BSM6179-N03PV0050 BSM6779-N03PV0050	BSM6179-N07PV0050 BSM6779-N07PV0050	
65	2"1/2	153	8,90	BSM6179-N03PV0065 BSM6779-N03PV0065	BSM6179-N07PV0065 BSM6779-N07PV0065	
80	3"	172	13,05	BSM6179-N03PV0080 BSM6779-N03PV0080	BSM6179-N07PV0080 BSM6779-N07PV0080	
100	4"	221	22,40	BSM6179-N03PV0100 BSM6779-N03PV0100	BSM6179-N07PV0100 BSM6779-N07PV0100	



**Retrouvez nos options et accessoires pour vérin pneumatique TECOFI page 57 à 64 (électropositionneurs, boîtiers fin de course, filtres, positionneurs).
Find all options and accessories p.57 to 64 for pneumatic actuator (solenoid valve, limit switch box, filters, positioners).**

BSM6179-N04 | BSM6179-N24 | BSM6779-N04 | BSM6779-N24

Robinet à boisseau sphérique 2 pièces femelle BSP / NPT - Inox - avec moteur TECOFI

Split-body ball valve female BSP / NPT - Stainless steel - with TECOFI actuator



BSM6179 : Femelle BSP / Female BSP
BSM6779 : Femelle NPT / Female NPT



Corps : Acier inoxydable A351 CF8M
Sphère : Acier inoxydable AISI 316
Axe : Acier inoxydable AISI 316
Étanchéité : PTFE chargé 15% verre
Pression de service max : 63 bar
Température de service : -25°C/+180°C
ΔP de calcul maxi : 10 bar

Body: Stainless steel A351 CF8M
Ball: Stainless steel AISI 316
Stem: Stainless steel AISI 316
Seal: 15% glass reinforced PTFE
Maximum working pressure: 63 bar
Working temperature: -25°C/+180°C
ΔP of max calculation: 10 bar



				Moteur électrique TECOFI TECOFI electric actuator	
				TRI 400V/50/60Hz	MONO 230V/50/60Hz
DN		T L (mm)	Kg	Ref.	Ref.
mm	inch				
40	1 1/2	105	4,14	BSM6179-N04PV0040	BSM6179-N24PV0040
				BSM6779-N04PV0040	BSM6779-N24PV0040
50	2"	125	5,10	BSM6179-N04PV0050	BSM6179-N24PV0050
				BSM6779-N04PV0050	BSM6779-N24PV0050
65	2 1/2	153	9,77	BSM6179-N04PV0065	BSM6179-N24PV0065
				BSM6779-N04PV0065	BSM6779-N24PV0065
80	3"	172	12,45	BSM6179-N04PV0080	BSM6179-N24PV0080
				BSM6779-N04PV0080	BSM6779-N24PV0080
100	4"	221	22,60	BSM6179-N04PV0100	BSM6179-N24PV0100
				BSM6779-N04PV0100	BSM6779-N24PV0100



ATEX sur demande / ATEX on request

BSM6179-U04 | BSM6179-U24 | BSM6779-U04 | BSM6779-U24

Robinet à boisseau sphérique 2 pièces femelle BSP / NPT - Inox - avec moteur AUMA

Split-body ball valve female BSP / NPT - Stainless steel - with AUMA actuator



BSM6179 : Femelle BSP / Female BSP
BSM6779 : Femelle NPT / Female NPT



Corps : Acier inoxydable A351 CF8M
Sphère : Acier inoxydable AISI 316
Axe : Acier inoxydable AISI 316
Étanchéité : PTFE chargé 15% verre
Pression de service max : 63 bar
Température de service : -25°C/+180°C
ΔP de calcul maxi : 10 bar

Body: Stainless steel A351 CF8M
Ball: Stainless steel AISI 316
Stem: Stainless steel AISI 316
Seal: 15% glass reinforced PTFE
Maximum working pressure: 63 bar
Working temperature: -25°C/+180°C
ΔP of max calculation: 10 bar



				Moteur électrique AUMA AUMA electric actuator	
				TRI 400V/50Hz	MONO 230V/50Hz
DN		T L (mm)	Kg	Ref.	Ref.
mm	inch				
40	1 1/2	105	5,94	BSM6179-U04PV0040	BSM6179-U24PV0040
				BSM6779-U04PV0040	BSM6779-U24PV0040
50	2"	125	6,9	BSM6179-U04PV0050	BSM6179-U24PV0050
				BSM6779-U04PV0050	BSM6779-U24PV0050
65	2 1/2	153	13,27	BSM6179-U04PV0065	BSM6179-U24PV0065
				BSM6779-U04PV0065	BSM6779-U24PV0065
80	3"	172	15,95	BSM6179-U04PV0080	BSM6179-U24PV0080
				BSM6779-U04PV0080	BSM6779-U24PV0080
100	4"	221	24,1	BSM6179-U04PV0100	BSM6179-U24PV0100
				BSM6779-U04PV0100	BSM6779-U24PV0100



ATEX sur demande / ATEX on request

BSM6179-B04 | BSM6179-B24 | BSM6779-B04 | BSM6779-B24

Robinet à boisseau sphérique 2 pièces femelle BSP / NPT - Inox - avec moteur BERNARD CONTROLS

Split-body ball valve female BSP / NPT - Stainless steel - with BERNARD CONTROLS actuator



BSM6179 : Femelle BSP / Female BSP
BSM6779 : Femelle NPT / Female NPT



Corps : Acier inoxydable A351 CF8M
Sphère : Acier inoxydable AISI 316
Axe : Acier inoxydable AISI 316
Étanchéité : PTFE chargé 15% verre
Pression de service max : 63 bar
Température de service : -25°C/+180°C
ΔP de calcul maxi : 10 bar

Body: Stainless steel A351 CF8M
Ball: Stainless steel AISI 316
Stem: Stainless steel AISI 316
Seal: 15% glass reinforced PTFE
Maximum working pressure: 63 bar
Working temperature: -25°C/+180°C
ΔP of max calculation: 10 bar



				Moteur électrique BERNARD CONTROLS BERNARD CONTROLS electric actuator	
				TRI 400V/50Hz	MONO 230V/50Hz
DN		T L (mm)	Kg	Ref.	Ref.
mm	inch				
40	1 1/2	105	8,94	BSM6179-B04PV0040	BSM6179-B24PV0040
				BSM6779-B04PV0040	BSM6779-B24PV0040
50	2"	125	9,9	BSM6179-B04PV0050	BSM6179-B24PV0050
				BSM6779-B04PV0050	BSM6779-B24PV0050
65	2 1/2	153	12,73	BSM6179-B04PV0065	BSM6179-B24PV0065
				BSM6779-B04PV0065	BSM6779-B24PV0065
80	3"	172	15,41	BSM6179-B04PV0080	BSM6179-B24PV0080
				BSM6779-B04PV0080	BSM6779-B24PV0080
100	4"	221	23,6	BSM6179-B04PV0100	BSM6179-B24PV0100
				BSM6779-B04PV0100	BSM6779-B24PV0100



ATEX sur demande / ATEX on request





ROBINETS À BOISSEAU SPHÉRIQUE INOX 3 PIÈCES
3-PIECE STAINLESS STEEL BALL VALVES

BS6375BSP | BS6375BW | BS6375SW | BS6375NPT

Robinet à boisseau sphérique passage intégral 3 pièces - Inox
 3-piece full bore ball valve - *Stainless steel*



Joint FDA (agrément alimentaire)
FDA joint (food grade approval)



- BS6375BSP** : Femelle BSP / Female BSP
- BS6375BW** : A souder en bout / Butt welding connection
- BS6375SW** : A souder par emboîtement / Socket welding connection
- BS6375NPT** : Femelle NPT / Female NPT

Corps : ASTM A351 CF8M
 Sphère : AISI 316
 Axe : AISI 316
 Etanchéité : PTFE FDA
 Pression de service max :
 DN1/4" - DN2" : 63 bar
 DN2"1/2 - DN4" : 50 bar
 Température de service : -20°C/+200°C

Body: ASTM A351 CF8M
 Ball: AISI 316
 Stem: AISI 316
 Seal: PTFE FDA
 Maximum working pressure:
 DN1/4" - DN2": 63 bar
 DN2"1/2 - DN4": 50 bar
 Working temperature: -20°C/+200°C

DN		Ps	L (mm)	Kg	Ref.
mm	inch				
8	1/4"	63	55	0,28	BS6375BSP-0008
					BS6375BW-0008
					BS6375SW-0008
10	3/8"	63	60	0,27	BS6375NPT-0008
					BS6375BSP-0010
					BS6375BW-0010
15	1/2"	63	75	0,44	BS6375SW-0010
					BS6375NPT-0010
					BS6375BSP-0015
20	3/4"	63	80	0,61	BS6375BW-0015
					BS6375SW-0015
					BS6375NPT-0015
25	1"	63	90	0,82	BS6375BSP-0020
					BS6375BW-0020
					BS6375SW-0020
32	1"1/4	63	110	1,47	BS6375NPT-0020
					BS6375BSP-0025
					BS6375BW-0025
40	1"1/2	63	120	1,8	BS6375SW-0025
					BS6375NPT-0025
					BS6375BSP-0040
50	2"	63	140	2,86	BS6375BW-0040
					BS6375SW-0040
					BS6375NPT-0040
65	2"1/2	50	162	5,64	BS6375BSP-0050
					BS6375BW-0050
					BS6375SW-0050
80	3"	50	184	8,24	BS6375NPT-0050
					BS6375BSP-0065
					BS6375BW-0065
100	4"	50	228	17,12	BS6375SW-0065
					BS6375NPT-0065
					BS6375BSP-0080
					BS6375BW-0080
					BS6375SW-0080
					BS6375NPT-0080
					BS6375BSP-0100
					BS6375BW-0100
					BS6375SW-0100
					BS6375NPT-0100

BS6375I-BSP

Robinet à boisseau sphérique passage intégral avec platine ISO - Inox - Sécurité feu

Full bore ball valve with ISO mounting plate - Stainless steel - Fire safe



Corps et sphère :
DN1/4" - 3/8" : CF8M
Au-delà : AISI 316
Pleine jusqu'au DN1"1/4
Creuse au-delà du DN1"1/4
Axe : AISI 316
Etanchéité : PTFE renforcé 15% graphoil
Pression de service :
DN1/4" - DN1" : 137,9 bar
DN1"1/4 - DN2" : 103,4 bar
Température de service : -20°C/+200°C
Platine ISO 5211
ATEX

**JUSQU'À ÉPUISEMENT DES STOCKS
WHILE STOCKS LAST**

DN		L (mm)	Kg	Ref.
mm	inch			
8	1/4"	65,7	0,70	BS6375I-BSP-0008
10	3/8"	65,7	0,70	BS6375I-BSP-0010
15	1/2"	75	0,90	BS6375I-BSP-0015
20	3/4"	80	1,20	BS6375I-BSP-0020
25	1"	93	2,30	BS6375I-BSP-0025
32	1"1/4	110	3,60	BS6375I-BSP-0032
40	1"1/2	120	5,10	BS6375I-BSP-0040
50	2"	140	7,60	BS6375I-BSP-0050
65	2"1/2	184	10,90	BS6375I-BSP-0065
80	3"	204	16,30	BS6375I-BSP-0080
100	4"	240	26	BS6375I-BSP-0100



Body and Ball:
DN1/4" - 3/8" : CF8M
DN beyond: AISI 316
Solid ball up to DN1"1/4
Hollow ball beyond DN1"1/4
Stem: AISI 316
Seal: 15% graphoil reinforced PTFE
Working pressure:
DN1/4" - DN1" : 137,9 bar
DN1"1/4 - DN2" : 103,4 bar
Working temperature: -20°C/+200°C
ISO 5211 mounting plate
ATEX

**Sécurité feu API 607
Fire safe API 607**

PRODUITS ASSOCIÉS | RELATED PRODUCTS

Motorisation électrique et pneumatique | Electric and pneumatic actuator

N24 | N04

Motorisation électrique TEA pour BS6375I
TEA electric actuator for BS6375I



Moteur équipé de :
- 2 contacts fin de course
- 1 résistance de chauffe
Commande manuelle de secours
Indicateur visuel de position
ΔP de calcul : 10 bar

Actuator equipped:
- 2 limit switches
- 1 heating resistor
Emergency handwheel
Opening indicator
ΔP of calculation: 10 bar

**Protection IP67
IP67 protection**

**Moteur électrique TECOFI /
TECOFI electric actuator
MONO 230V/50/60Hz**

**Moteur électrique TECOFI /
TECOFI electric actuator
TRI 400V/50/60Hz**

DN		Type	Ref.	Type	Ref.
mm	inch				
8	1/4"	TEA-05N24	300180335	TEA-05N04	300180334
10	3/8"	TEA-05N24	300180335	TEA-05N04	300180334
15	1/2"	TEA-05N24	300180156	TEA-05N04	300180157
20	3/4"	TEA-05N24	300180156	TEA-05N04	300180157
25	1"	TEA-05N24	300180158	TEA-05N04	300180159
32	1"1/4	TEA-05N24	300180158	TEA-05N04	300180159
40	1"1/2	TEA-05N24	300180160	TEA-05N04	300180161
50	2"	TEA-05N24	300180160	TEA-05N04	300180161
65	2"1/2	TEA-10N24	300180163	TEA-10N04	300180162
80	3"	TEA-20N24	300180164	TEA-20N04	300180165
100	4"	TEA-20N24	300180166	TEA-20N04	300180167

N03 | N07

Motorisation pneumatique TDA / TSR pour BS6375I
TDA / TSR pneumatic actuator for BS6375I



Construction : Aluminium
Pression de service : 6 bar (air lubrifié)
Butées réglables
ΔP de calcul : 10 bar

Construction: Aluminium
Working pressure: 6 bar (air lubricated)
Stop bolt retaining nut
ΔP of calculation: 10 bar



ATEX sur demande / ATEX on request

Double effet / Double-acting

Simple effet / Single-acting

DN		Type	Ref.	Type	Ref.
mm	inch				
8	1/4"	TDA-052	300180145	TSR-052	300180142
10	3/8"	TDA-052	300180145	TSR-052	300180142
15	1/2"	TDA-052	300180145	TSR-052	300180144
20	3/4"	TDA-032	300180143	TSR-052	300180144
25	1"	TDA-052	300180145	TSR-052	300180146
32	1"1/4	TDA-052	300180145	TSR-063	300180147
40	1"1/2	TDA-063	300180148	TSR-075	300180149
50	2"	TDA-063	300180148	TSR-075	300180149
65	2"1/2	TDA-083	300180150	TSR-092	300180151
80	3"	TDA-092	300180152	TSR-125	300180153
100	4"	TDA-105	300180154	TSR-125	300180155



**Retrouvez nos options et accessoires pour vérin pneumatique TECOFI page 57 à 64 (électropositionneurs, boîtiers fin de course, filtres, positionneurs).
Find all options and accessories p.57 to 64 for pneumatic actuator (solenoid valve, limit switch box, filters, positioners).**

BSE6189 | BSE6789 | BSE6389 | BSE6989

Robinet à boisseau sphérique 3 pièces BSP / NPT / SW / BW - Inox
 3-piece ball valve - BSP/NPT/SW/BW connection - Stainless steel

**BIENTÔT DISPONIBLE - AVRIL 2021
 COMING SOON - APRIL 2021**



Modèle NPT
NPT type



- BSE6189** : Femelle BSP / Female BSP
- BSE6789** : Femelle NPT / Female NPT
- BSE6389** : SW (à souder par emboîtement / Socket welding connection)
- BSE6989** : BW (à souder en bout / Butt welding connection)

Corps : Acier inoxydable A351 CF8M
 Sphère : Acier inoxydable AISI 316
 Axe : Acier inoxydable AISI 316
 Etanchéité : PTFE
 Pression de service max : 130 bar
 Température de service : -25°C/+180°C
 Platine ISO 5211
 ATEX : II 2 GD C T2

Body: Stainless steel A351 CF8M
 Ball: Stainless steel AISI 316
 Stem: Stainless steel AISI 316
 Seal: PTFE
 Maximum working pressure: 130 bar
 Working temperature: -25°C/+180°C
 ISO 5211 mounting plate
 ATEX: II 2 GD C T2



**Replace
 Replace
 BS63751**



**Haute pression
 Sécurité feu
 High pressure
 Fire safe**

**Poignée cadenassable
 Lockable handle**

A levier platine ISO Lever with ISO mounting plate					
DN		L (mm)	Kg	Raccordement Connection	Ref.
mm	inch				
08	1/4"	50	0,51	BSP	BSE6189-02PV0008
				NPT	BSE6789-02PV0008
				SW	BSE6389-02PV0008
				BW	BSE6989-02PV0008
10	3/8"	60	0,56	BSP	BSE6189-02PV0010
				NPT	BSE6789-02PV0010
				SW	BSE6389-02PV0010
				BW	BSE6989-02PV0010
15	1/2"	75	0,82	BSP	BSE6189-02PV0015
				NPT	BSE6789-02PV0015
				SW	BSE6389-02PV0015
				BW	BSE6989-02PV0015
20	3/4"	80	1,36	BSP	BSE6189-02PV0020
				NPT	BSE6789-02PV0020
				SW	BSE6389-02PV0020
				BW	BSE6989-02PV0020
25	1"	90	1,83	BSP	BSE6189-02PV0025
				NPT	BSE6789-02PV0025
				SW	BSE6389-02PV0025
				BW	BSE6989-02PV0025
32	1"1/4	110	3,22	BSP	BSE6189-02PV0032
				NPT	BSE6789-02PV0032
				SW	BSE6389-02PV0032
				BW	BSE6989-02PV0032
40	1"1/2	120	4,47	BSP	BSE6189-02PV0040
				NPT	BSE6789-02PV0040
				SW	BSE6389-02PV0040
				BW	BSE6989-02PV0040
50	2"	140	6,37	BSP	BSE6189-02PV0050
				NPT	BSE6789-02PV0050
				SW	BSE6389-02PV0050
				BW	BSE6989-02PV0050
65	2"1/2	185	8,58	BSP	BSE6189-02PV0065
				NPT	BSE6789-02PV0065
				SW	BSE6389-02PV0065
				BW	BSE6989-02PV0065
80	3"	205	13,3	BSP	BSE6189-02PV0080
				NPT	BSE6789-02PV0080
				SW	BSE6389-02PV0080
				BW	BSE6989-02PV0080
100	4"	240	22,3	BSP	BSE6189-02PV0100
				NPT	BSE6789-02PV0100
				SW	BSE6389-02PV0100
				BW	BSE6989-02PV0100

ROBINET BOISSEAU
SPHÉRIQUE | BALL VALVE

BSE6189-N03 | BSE6789-N03 | BSE6389-N03 | BSE6989-N03 | BSE6189-N07 | BSE6789-N07 | BSE6389-N07 | BSE6989-N07

Robinet à boisseau sphérique 3 pièces BSP / NPT / SW / BW - Inox - à vérin pneumatique

3-piece ball valve - BSP/NPT/SW/BW connection - Stainless steel with pneumatic actuator



Modèle NPT
NPT type



Haute pression
High pressure



BSE6189 : Femelle BSP / Female BSP
BSE6789 : Femelle NPT / Female NPT
BSE6389 : SW (à souder par emboîtement / Socket welding connection)
BSE6989 : BW (à souder en bout / Butt welding connection)

Corps : Acier inoxydable A351 CF8M
Sphère : Acier inoxydable AISI 316
Axe : Acier inoxydable AISI 316
Étanchéité : PTFE
Pression de service max : 130 bar
Température de service : -25°C/+180°C
ΔP de calcul maxi : 10 bar

Body: Stainless steel A351 CF8M
Ball: Stainless steel AISI 316
Stem: Stainless steel AISI 316
Seal: PTFE
Maximum working pressure: 130 bar
Working temperature: -25°C/+180°C
ΔP of max calculation: 10 bar



ATEX sur demande / ATEX on request

				Vérin pneumatique Pneumatic actuator	
				Double effet / Double-acting	Simple effet / Single-acting
DN		L (mm)	Kg	Ref.	Ref.
mm	inch				
08	1/4"	50	2,11	BSE6189-N03PV0008 BSE6789-N03PV0008 BSE6389-N03PV0008 BSE6989-N03PV0008	BSE6189-N07PV0008 BSE6789-N07PV0008 BSE6389-N07PV0008 BSE6989-N07PV0008
10	3/8"	60	2,16	BSE6189-N03PV0010 BSE6789-N03PV0010 BSE6389-N03PV0010 BSE6989-N03PV0010	BSE6189-N07PV0010 BSE6789-N07PV0010 BSE6389-N07PV0010 BSE6989-N07PV0010
15	1/2"	75	2,20	BSE6189-N03PV0015 BSE6789-N03PV0015 BSE6389-N03PV0015 BSE6989-N03PV0015	BSE6189-N07PV0015 BSE6789-N07PV0015 BSE6389-N07PV0015 BSE6989-N07PV0015
20	3/4"	80	2,74	BSE6189-N03PV0020 BSE6789-N03PV0020 BSE6389-N03PV0020 BSE6989-N03PV0020	BSE6189-N07PV0020 BSE6789-N07PV0020 BSE6389-N07PV0020 BSE6989-N07PV0020
25	1"	90	3,21	BSE6189-N03PV0025 BSE6789-N03PV0025 BSE6389-N03PV0025 BSE6989-N03PV0025	BSE6189-N07PV0025 BSE6789-N07PV0025 BSE6389-N07PV0025 BSE6989-N07PV0025
32	1 1/4"	110	5,25	BSE6189-N03PV0032 BSE6789-N03PV0032 BSE6389-N03PV0032 BSE6989-N03PV0032	BSE6189-N07PV0032 BSE6789-N07PV0032 BSE6389-N07PV0032 BSE6989-N07PV0032
40	1 1/2"	120	6,5	BSE6189-N03PV0040 BSE6789-N03PV0040 BSE6389-N03PV0040 BSE6989-N03PV0040	BSE6189-N07PV0040 BSE6789-N07PV0040 BSE6389-N07PV0040 BSE6989-N07PV0040
50	2"	140	8,4	BSE6189-N03PV0050 BSE6789-N03PV0050 BSE6389-N03PV0050 BSE6989-N03PV0050	BSE6189-N07PV0050 BSE6789-N07PV0050 BSE6389-N07PV0050 BSE6989-N07PV0050
65	2 1/2"	185	11,71	BSE6189-N03PV0065 BSE6789-N03PV0065 BSE6389-N03PV0065 BSE6989-N03PV0065	BSE6189-N07PV0065 BSE6789-N07PV0065 BSE6389-N07PV0065 BSE6989-N07PV0065
80	3"	205	17,9	BSE6189-N03PV0080 BSE6789-N03PV0080 BSE6389-N03PV0080 BSE6989-N03PV0080	BSE6189-N07PV0080 BSE6789-N07PV0080 BSE6389-N07PV0080 BSE6989-N07PV0080
100	4"	240	29,07	BSE6189-N03PV0100 BSE6789-N03PV0100 BSE6389-N03PV0100 BSE6989-N03PV0100	BSE6189-N07PV0100 BSE6789-N07PV0100 BSE6389-N07PV0100 BSE6989-N07PV0100

BSE6189-N04 | BSE6789-N04 | BSE6389-N04 | BSE6989-N04 | BSE6189-N24 | BSE6789-N24 | BSE6389-N24 | BSE6989-N24

Robinet à boisseau sphérique 3 pièces BSP / NPT / SW / BW - Inox - avec moteur TECOFI

3-piece ball valve - BSP/NPT/SW/BW connection - Stainless steel with TECOFI electric actuator



Modèle NPT
NPT type



Haute pression
High pressure



BSE6189 : Femelle BSP / Female BSP
BSE6789 : Femelle NPT / Female NPT
BSE6389 : SW (à souder par emboîtement / Socket welding connection)
BSE6989 : BW (à souder en bout / Butt welding connection)

Corps : Acier inoxydable A351 CF8M
Sphère : Acier inoxydable AISI 316
Axe : Acier inoxydable AISI 316
Étanchéité : PTFE
Pression de service max : 130 bar
Température de service : -25°C/+180°C
ΔP de calcul maxi : 10 bar

Body: Stainless steel A351 CF8M
Ball: Stainless steel AISI 316
Stem: Stainless steel AISI 316
Seal: PTFE
Maximum working pressure: 130 bar
Working temperature: -25°C/+180°C
ΔP of max calculation: 10 bar



ATEX sur demande / ATEX on request

				Moteur électrique TECOFI / TECOFI electric actuator	
				TRI 400V/50/60Hz	MONO 230V/50/60Hz
DN		L (mm)	Kg	Ref.	Ref.
mm	inch				
32	1 1/4"	110	5,42	BSE6189-N04PV0032 BSE6789-N04PV0032 BSE6389-N04PV0032 BSE6989-N04PV0032	BSE6189-N24PV0032 BSE6789-N24PV0032 BSE6389-N24PV0032 BSE6989-N24PV0032
40	1 1/2"	120	6,67	BSE6189-N04PV0040 BSE6789-N04PV0040 BSE6389-N04PV0040 BSE6989-N04PV0040	BSE6189-N24PV0040 BSE6789-N24PV0040 BSE6389-N24PV0040 BSE6989-N24PV0040
50	2"	140	8,57	BSE6189-N04PV0050 BSE6789-N04PV0050 BSE6389-N04PV0050 BSE6989-N04PV0050	BSE6189-N24PV0050 BSE6789-N24PV0050 BSE6389-N24PV0050 BSE6989-N24PV0050
65	2 1/2"	185	12,58	BSE6189-N04PV0065 BSE6789-N04PV0065 BSE6389-N04PV0065 BSE6989-N04PV0065	BSE6189-N24PV0065 BSE6789-N24PV0065 BSE6389-N24PV0065 BSE6989-N24PV0065
80	3"	205	17,3	BSE6189-N04PV0080 BSE6789-N04PV0080 BSE6389-N04PV0080 BSE6989-N04PV0080	BSE6189-N24PV0080 BSE6789-N24PV0080 BSE6389-N24PV0080 BSE6989-N24PV0080
100	4"	240	29,3	BSE6189-N04PV0100 BSE6789-N04PV0100 BSE6389-N04PV0100 BSE6989-N04PV0100	BSE6189-N24PV0100 BSE6789-N24PV0100 BSE6389-N24PV0100 BSE6989-N24PV0100

BSE6189-U04 | BSE6789-U04 | BSE6389-U04 | BSE6989-U04 | BSE6189-U24 | BSE6789-U24 | BSE6389-U24 | BSE6989-U24

Robinet à boisseau sphérique 3 pièces BSP / NPT / SW / BW - Inox - avec moteur AUMA

3-piece ball valve - BSP/NPT/SW/BW connection - Stainless steel with AUMA electric actuator



auma
Technik für ein weltweites Netzwerk

Modèle NPT
NPT type



**Haute pression
High pressure**



- BSE6189** : Femelle BSP / Female BSP
- BSE6789** : Femelle NPT / Female NPT
- BSE6389** : SW (à souder par emboîtement / Socket welding connection)
- BSE6989** : BW (à souder en bout / Butt welding connection)

Corps : Acier inoxydable A351 CF8M
Sphère : Acier inoxydable AISI 316
Axe : Acier inoxydable AISI 316
Étanchéité : PTFE
Pression de service max : 130 bar
Température de service : -25°C/+180°C
ΔP de calcul maxi : 10 bar

Body: Stainless steel A351 CF8M
Ball: Stainless steel AISI 316
Stem: Stainless steel AISI 316
Seal: PTFE
Maximum working pressure: 130 bar
Working temperature: -25°C/+180°C
ΔP of maxi calculation: 10 bar



ATEX sur demande / ATEX on request

				Moteur électrique AUMA AUMA electric actuator	
				TRI 400V/50Hz	MONO 230V/50Hz
DN		L (mm)	Kg	Ref.	
mm	inch				
32	1 1/4	110	7,22	BSE6189-U04PV0032 BSE6789-U04PV0032 BSE6389-U04PV0032 BSE6989-U04PV0032	BSE6189-U24PV0032 BSE6789-U24PV0032 BSE6389-U24PV0032 BSE6989-U24PV0032
40	1 1/2	120	8,47	BSE6189-U04PV0040 BSE6789-U04PV0040 BSE6389-U04PV0040 BSE6989-U04PV0040	BSE6189-U24PV0040 BSE6789-U24PV0040 BSE6389-U24PV0040 BSE6989-U24PV0040
50	2"	140	10,37	BSE6189-U04PV0050 BSE6789-U04PV0050 BSE6389-U04PV0050 BSE6989-U04PV0050	BSE6189-U24PV0050 BSE6789-U24PV0050 BSE6389-U24PV0050 BSE6989-U24PV0050
65	2 1/2	185	16,08	BSE6189-U04PV0065 BSE6789-U04PV0065 BSE6389-U04PV0065 BSE6989-U04PV0065	BSE6189-U24PV0065 BSE6789-U24PV0065 BSE6389-U24PV0065 BSE6989-U24PV0065
80	3"	205	20,8	BSE6189-U04PV0080 BSE6789-U04PV0080 BSE6389-U04PV0080 BSE6989-U04PV0080	BSE6189-U24PV0080 BSE6789-U24PV0080 BSE6389-U24PV0080 BSE6989-U24PV0080
100	4"	240	29,8	BSE6189-U04PV0100 BSE6789-U04PV0100 BSE6389-U04PV0100 BSE6989-U04PV0100	BSE6189-U24PV0100 BSE6789-U24PV0100 BSE6389-U24PV0100 BSE6989-U24PV0100

BSE6189-B04 | BSE6789-B04 | BSE6389-B04 | BSE6989-B04 | BSE6189-B24 | BSE6789-B24 | BSE6389-B24 | BSE6989-B24

Robinet à boisseau sphérique 3 pièces BSP / NPT / SW / BW - Inox - avec moteur BERNARD CONTROLS

3-piece ball valve - BSP/NPT/SW/BW connection - Stainless steel with BERNARD CONTROLS electric actuator



**BERNARD
CONTROLS**

Modèle NPT
NPT type



**Haute pression
High pressure**



- BSE6189** : Femelle BSP / Female BSP
- BSE6789** : Femelle NPT / Female NPT
- BSE6389** : SW (à souder par emboîtement / Socket welding connection)
- BSE6989** : BW (à souder en bout / Butt welding connection)

Corps : Acier inoxydable A351 CF8M
Sphère : Acier inoxydable A351 CF8M
Axe : Acier inoxydable AISI 316
Étanchéité : PTFE
Pression de service max : 130 bar
Température de service : -25°C/+180°C
ΔP de calcul maxi : 10 bar

Body: Stainless steel A351 CF8M
Ball: Stainless steel AISI 316
Stem: Stainless steel AISI 316
Seal: PTFE
Maximum working pressure: 130 bar
Working temperature: -25°C/+180°C
ΔP of max calculation: 10 bar



ATEX sur demande / ATEX on request

				Moteur électrique BERNARD CONTROLS BERNARD CONTROLS electric actuator	
				TRI 400V/50Hz	MONO 230V/50Hz
DN		L (mm)	Kg	Ref.	
mm	inch				
32	1 1/4	110	10,22	BSE6189-B04PV0032 BSE6789-B04PV0032 BSE6389-B04PV0032 BSE6989-B04PV0032	BSE6189-B24PV0032 BSE6789-B24PV0032 BSE6389-B24PV0032 BSE6989-B24PV0032
40	1 1/2	120	11,47	BSE6189-B04PV0040 BSE6789-B04PV0040 BSE6389-B04PV0040 BSE6989-B04PV0040	BSE6189-B24PV0040 BSE6789-B24PV0040 BSE6389-B24PV0040 BSE6989-B24PV0040
50	2"	140	13,37	BSE6189-B04PV0050 BSE6789-B04PV0050 BSE6389-B04PV0050 BSE6989-B04PV0050	BSE6189-B24PV0050 BSE6789-B24PV0050 BSE6389-B24PV0050 BSE6989-B24PV0050
65	2 1/2	185	15,54	BSE6189-B04PV0065 BSE6789-B04PV0065 BSE6389-B04PV0065 BSE6989-B04PV0065	BSE6189-B24PV0065 BSE6789-B24PV0065 BSE6389-B24PV0065 BSE6989-B24PV0065
80	3"	205	20,26	BSE6189-B04PV0080 BSE6789-B04PV0080 BSE6389-B04PV0080 BSE6989-B04PV0080	BSE6189-B24PV0080 BSE6789-B24PV0080 BSE6389-B24PV0080 BSE6989-B24PV0080
100	4"	240	29,3	BSE6189-B04PV0100 BSE6789-B04PV0100 BSE6389-B04PV0100 BSE6989-B04PV0100	BSE6189-B24PV0100 BSE6789-B24PV0100 BSE6389-B24PV0100 BSE6989-B24PV0100

ROBINET BOISSEAU SPHÉRIQUE | BALL VALVE



ROBINETS À BOISSEAU SPHÉRIQUE INOX À BRIDES
STAINLESS STEEL FLANGED BALL VALVES

BS6245

Robinet à boisseau sphérique passage intégral WAFER trous taraudés - Inox - PN16

Flanged full bore ball valve - stainless steel - PN16



Modèle / Serie
DN125-150



Modèle / Serie
DN15-100



Corps : CF8M
 Sphère : AISI 316
 Axe : AISI 316
 Etanchéité : PTFE
 Raccordement : A brides PN10/16
 DN15 à DN100 : Entre brides
 DN125 - DN150 : A brides
 Pression de service max : 16 bar
 Température de service : -20°C/+200°C

Body: CF8M
 Ball: AISI 316
 Stem: AISI 316
 Tightness: PTFE
 Connection: PN10/16 flanged
 DN15 à DN100: Wafer
 DN125 - 150: Flanged
 Maximum working pressure: 16 bar
 Working temperature: -20°C/+200°C

A levier platine ISO Lever with ISO mounting plate				
DN		L (mm)	Kg	Ref.
mm	inch			
15	1/2"	36	1,2	BS6245-0015
20	3/4"	38	1,4	BS6245-0020
25	1"	43	1,9	BS6245-0025
32	1"1/4	51	2,9	BS6245-0032
40	1"1/2	63	4,4	BS6245-0040
50	2"	70	5,6	BS6245-0050
65	2"1/2	107	9,9	BS6245-0065
80	3"	120	12,6	BS6245-0080
100	4"	152	19,7	BS6245-0100
125	5"	180	29,2	BS6245-0125
150	6"	236	39,8	BS6245-0150

BS6245-N03 | BS6245-N07

Robinet à boisseau sphérique passage intégral WAFER trous taraudés PN16 - Inox - à vérin pneumatique

Flanged full bore ball valve - Stainless steel - PN16 - with pneumatic actuator



Modèle / Serie
DN125-150



Corps : CF8M
 Sphère : AISI 316
 Axe : AISI 316
 Etanchéité : PTFE
 Raccordement : A brides PN10/16
 DN15 à DN100 : Entre brides
 DN125 - DN150 : A brides
 Pression de service max : 16 bar
 Température de service : -20°C/+200°C
 ΔP de calcul maxi : 10 bar

Body: CF8M
 Ball: AISI 316
 Stem: AISI 316
 Tightness: PTFE
 Connection: PN10/16 flanged
 DN15 à DN100: Wafer
 DN125 - DN150: Flanged
 Maximum working pressure: 16 bar
 Working temperature: -20°C/+200°C
 ΔP of maxi calculation: 10 bar

					Vérin pneumatique Pneumatic actuator	
					Double effet / Double-acting	Simple effet / Single-acting
DN		L (mm)	Kg	Ref.	Ref.	Ref.
mm	inch					
15	1/2"	36	2,96	BS6245-N03-0015		BS6245-N07-0015
20	3/4"	38	3,16	BS6245-N03-0020		BS6245-N07-0020
25	1"	43	3,66	BS6245-N03-0025		BS6245-N07-0025
32	1"1/4	51	4,66	BS6245-N03-0032		BS6245-N07-0032
40	1"1/2	63	7,21	BS6245-N03-0040		BS6245-N07-0040
50	2"	70	8,41	BS6245-N03-0050		BS6245-N07-0050
65	2"1/2	107	13,99	BS6245-N03-0065		BS6245-N07-0065
80	3"	120	16,69	BS6245-N03-0080		BS6245-N07-0080
100	4"	152	26,10	BS6245-N03-0100		BS6245-N07-0100
125	5"	180	36,94	BS6245-N03-0125		BS6245-N07-0125
150	6"	236	51,40	BS6245-N03-0150		BS6245-N07-0150

BS6245-N04 | BS6245-N24

Robinet à boisseau sphérique passage intégral WAFER trous taraudés PN16 - Inox - avec moteur électrique TECOFI

Flanged full bore ball valve - Stainless steel - PN16 - with TECOFI electric actuator



Modèle / Serie
DN125-150



Corps : CF8M
 Sphère : AISI 316
 Axe : AISI 316
 Etanchéité : PTFE
 Raccordement : A brides PN10/16
 DN15 à DN100 : Entre brides
 DN125 - DN150 : A brides
 Pression de service max : 16 bar
 Température de service : -20°C/+200°C
 ΔP de calcul maxi : 10 bar

Body: CF8M
 Ball: AISI 316
 Stem: AISI 316
 Tightness: PTFE
 Connection: PN10/16 flanged
 DN15 à DN100: Wafer
 DN125 - DN150: Flanged
 Maximum working pressure: 16 bar
 Working temperature: -20°C/+200°C
 ΔP of maxi calculation: 10 bar

					Moteur électrique TECOFI TECOFI electric actuator	
					TRI 400V/50/60Hz	MONO 230V/50/60Hz
DN		L (mm)	Kg	Ref.	Ref.	Ref.
mm	inch					
15	1/2"	36	3,67	BS6245-N04-0015		BS6245-N24-0015
20	3/4"	38	3,87	BS6245-N04-0020		BS6245-N24-0020
25	1"	43	4,37	BS6245-N04-0025		BS6245-N24-0025
32	1"1/4	51	5,37	BS6245-N04-0032		BS6245-N24-0032
40	1"1/2	63	7,23	BS6245-N04-0040		BS6245-N24-0040
50	2"	70	8,43	BS6245-N04-0050		BS6245-N24-0050
65	2"1/2	107	14,92	BS6245-N04-0065		BS6245-N24-0065
80	3"	120	17,62	BS6245-N04-0080		BS6245-N24-0080
100	4"	152	27,54	BS6245-N04-0100		BS6245-N24-0100
125	5"	180	36,44	BS6245-N04-0125		BS6245-N24-0125
150	6"	236	56,75	BS6245-N04-0150		BS6245-N24-0150

BSD6249

Robinet à boisseau sphérique 2 pièces à brides - Inox
2-piece flanged ball valve - split body - Stainless steel

**BIENTÔT DISPONIBLE - AVRIL 2021
COMING SOON - APRIL**



Corps : Acier inoxydable A351 CF8M
Sphère : Acier inoxydable AISI 316
Axe : Acier inoxydable AISI 316
Étanchéité : PTFE chargé 15% verre
Raccordement :
A brides PN16/40 jusqu'au DN50
A brides PN16 du DN65 au DN200
Pression de service max :
40 bar jusqu'au DN50
16 bar du DN65 au DN200
Température de service :
-25°C/+180°C
Platine ISO 5211
ATEX : II 2 GD C T2

Body : Stainless steel A351 CF8M
Ball : Stainless steel AISI 316
Stem : Stainless steel AISI 316
Seal : 15% glass reinforced PTFE
Connection :
Flanged PN16/40 up through DN50
Flanged PN16 from DN65 through DN200
Maximum working pressure :
40 bar up through DN50
16 bar from DN65 through DN200
Working temperature :
-25°C/+180°C
ISO 5211 mounting plate
ATEX : II 2 GD C T2



**Sécurité feu
API 607
Fire safe API 607**



**Passage intégral
Poignée cadenassable
Full bore
Lockable handle**

A levier platine ISO Lever with ISO mounting plate				
DN		L (mm)	Kg	Ref.
mm	inch			
15	1/2"	115	2,08	BSD6249-02PV0015
20	3/4"	120	2,8	BSD6249-02PV0020
25	1"	125	3,73	BSD6249-02PV0025
32	1"1/4	130	5,18	BSD6249-02PV0032
40	1"1/2	140	6,56	BSD6249-02PV0040
50	2"	150	8,9	BSD6249-02PV0050
65	2"1/2"	170	13,4	BSD6249-02PV0065
80	3"	180	18,2	BSD6249-02PV0080
100	4"	190	25,7	BSD6249-02PV0100
125	5"	325	50,5	BSD6249-02PV0125
150	6"	350	76,8	BSD6249-02PV0150
200	8"	400	125	BSD6249-02PV0200

BSD6249-N03 | BSD6249-N07

Robinet à boisseau sphérique 2 pièces à brides - Inox - à vérin pneumatique
2-piece flanged ball valve - split body - Stainless steel with pneumatic actuator



Corps : Acier inoxydable A351 CF8M
Sphère : Acier inoxydable AISI 316
Axe : Acier inoxydable AISI 316
Étanchéité : PTFE
Raccordement :
A brides PN16/40 jusqu'au DN50
A brides PN16 du DN65 au DN200
Pression de service max :
40 bar jusqu'au DN50
16 bar du DN65 au DN200
Température de service : -25°C/+180°C
ΔP de calcul maxi : 10 bar

Body : Stainless steel A351 CF8M
Ball : Stainless steel AISI 316
Stem : Stainless steel AISI 316
Seal : PTFE
Connection :
Flanged PN16/40 up through DN50
Flanged PN16 from DN65 through DN200
Maximum working pressure :
40 bar up through DN50
16 bar from DN65 through DN200
Working temperature : -25°C/+180°C
ΔP of maxi calculation : 10 bar



ATEX sur demande / ATEX on request

					Vérin pneumatique Pneumatic actuator	
DN		L (mm)	Kg			
mm	inch			Double effet Double-acting	Simple effet Single-acting	
				Ref.	Ref.	
15	1/2"	115	3	BSD6249-N03PV0015	BSD6249-N07PV0015	
20	3/4"	120	4,18	BSD6249-N03PV0020	BSD6249-N07PV0020	
25	1"	125	5,11	BSD6249-N03PV0025	BSD6249-N07PV0025	
32	1"1/4	130	6,56	BSD6249-N03PV0032	BSD6249-N07PV0032	
40	1"1/2	140	8,59	BSD6249-N03PV0040	BSD6249-N07PV0040	
50	2"	150	10,93	BSD6249-N03PV0050	BSD6249-N07PV0050	
65	2"1/2"	170	16,53	BSD6249-N03PV0065	BSD6249-N07PV0065	
80	3"	180	22,8	BSD6249-N03PV0080	BSD6249-N07PV0080	
100	4"	190	32,47	BSD6249-N03PV0100	BSD6249-N07PV0100	
125	5"	325	59,4	BSD6249-N03PV0125	BSD6249-N07PV0125	
150	6"	350	90,05	BSD6249-N03PV0150	BSD6249-N07PV0150	
200	8"	400	138,25	BSD6249-N03PV0200	BSD6249-N07PV0200	



Retrouvez nos options et accessoires pour vérin pneumatique TECOFI page 57 à 64 (électropositionneurs, boîtiers fin de course, filtres, positionneurs).
Find all options and accessories p.57 to 64 for pneumatic actuator (solenoid valve, limit switch box, filters, positioners).

BSD6249-N04 | BSD6249-N24

Robinet à boisseau sphérique 2 pièces à brides - Inox - avec moteur TECOFI

2-piece flanged ball valve - split body - Stainless steel with TECOFI electric actuator



Corps : Acier inoxydable A351 CF8M
 Sphère : Acier inoxydable AISI 316
 Axe : Acier inoxydable AISI 316
 Etanchéité : PTFE
 Raccordement :
 A brides PN16/40 jusqu'au DN50
 A brides PN16 du DN65 au DN200
 Pression de service max :
 40 bar jusqu'au DN50
 16 bar du DN65 au DN200
 Température de service : -25°C/+180°C
 ΔP de calcul maxi : 10 bar

Body: Stainless steel A351 CF8M
 Ball: Stainless steel AISI 316
 Stem: Stainless steel AISI 316
 Seal: PTFE
 Connection:
 Flanged PN16/40 up through DN50
 Flanged PN16 from DN65 through DN200
 Maximum working pressure:
 40 bar up through DN50
 16 bar from DN65 through DN200
 Working temperature: -25°C/+180°C
 ΔP of maxi calculation: 10 bar

				Moteur électrique TECOFI TECOFI electric actuator	
				TRI 400V/50/60Hz	MONO 230V/50/60Hz
DN		L (mm)	Kg	Ref.	Ref.
mm	inch				
25	1"	125	5,93	BSD6249-N04PV0025	BSD6249-N24PV0025
32	1"1/4	130	7,38	BSD6249-N04PV0032	BSD6249-N24PV0032
40	1"1/2	140	8,76	BSD6249-N04PV0040	BSD6249-N24PV0040
50	2"	150	11,1	BSD6249-N04PV0050	BSD6249-N24PV0050
65	2"1/2"	170	17,4	BSD6249-N04PV0065	BSD6249-N24PV0065
80	3"	180	22,2	BSD6249-N04PV0080	BSD6249-N24PV0080
100	4"	190	32,7	BSD6249-N04PV0100	BSD6249-N24PV0100
125	5"	325	58,3	BSD6249-N04PV0125	BSD6249-N24PV0125
150	6"	350	84,6	BSD6249-N04PV0150	BSD6249-N24PV0150
200	8"	400	132,8	BSD6249-N04PV0200	BSD6249-N24PV0200



ATEX sur demande / ATEX on request

BSD6249-U04 | BSD6249-U24

Robinet à boisseau sphérique 2 pièces à brides - Inox - avec moteur AUMA

2-piece flanged ball valve - split body - Stainless steel with AUMA electric actuator



Corps : Acier inoxydable A351 CF8M
 Sphère : Acier inoxydable AISI 316
 Axe : Acier inoxydable AISI 316
 Etanchéité : PTFE
 Raccordement :
 A brides PN16/40 jusqu'au DN50
 A brides PN16 du DN65 au DN200
 Pression de service max :
 40 bar jusqu'au DN50
 16 bar du DN65 au DN200
 Température de service : -25°C/+180°C
 ΔP de calcul maxi : 10 bar

Body: Stainless steel A351 CF8M
 Ball: Stainless steel AISI 316
 Stem: Stainless steel AISI 316
 Seal: PTFE
 Connection:
 Flanged PN16/40 up through DN50
 Flanged PN16 from DN65 through DN200
 Maximum working pressure:
 40 bar up through DN50
 16 bar from DN65 through DN200
 Working temperature: -25°C/+180°C
 ΔP of maxi calculation: 10 bar

				Moteur électrique AUMA AUMA electric actuator	
				TRI 400V/50Hz	MONO 230V/50Hz
DN		L (mm)	Kg	Ref.	Ref.
mm	inch				
25	1"	125	7,73	BSD6249-U04PV0025	BSD6249-U24PV0025
32	1"1/4	130	9,18	BSD6249-U04PV0032	BSD6249-U24PV0032
40	1"1/2	140	10,56	BSD6249-U04PV0040	BSD6249-U24PV0040
50	2"	150	12,9	BSD6249-U04PV0050	BSD6249-U24PV0050
65	2"1/2"	170	20,9	BSD6249-U04PV0065	BSD6249-U24PV0065
80	3"	180	25,7	BSD6249-U04PV0080	BSD6249-U24PV0080
100	4"	190	33,2	BSD6249-U04PV0100	BSD6249-U24PV0100
125	5"	325	65,5	BSD6249-U04PV0125	BSD6249-U24PV0125
150	6"	350	76,8	BSD6249-U04PV0150	BSD6249-U24PV0150
200	8"	400	125	BSD6249-U04PV0200	BSD6249-U24PV0200



ATEX sur demande / ATEX on request



BSD6249-B04 | BSD6249-B24

Robinet à boisseau sphérique 2 pièces à brides - Inox - avec moteur BERNARD CONTROLS

2-piece flanged ball valve - split body - Stainless steel with BERNARD CONTROLS electric actuator



Corps : Acier inoxydable A351 CF8M
 Sphère : Acier inoxydable AISI 316
 Axe : Acier inoxydable AISI 316
 Etanchéité : PTFE
 Raccordement :
 A brides PN16/40 jusqu'au DN50
 A brides PN16 du DN65 au DN200
 Pression de service max :
 40 bar jusqu'au DN50
 16 bar du DN65 au DN200
 Température de service : -25°C/+180°C
 ΔP de calcul maxi : 10 bar

Body: Stainless steel A351 CF8M
 Ball: Stainless steel AISI 316
 Stem: Stainless steel AISI 316
 Seal: PTFE
 Connection:
 Flanged PN16/40 up through DN50
 Flanged PN16 from DN65 through DN200
 Maximum working pressure:
 40 bar up through DN50
 16 bar from DN65 through DN200
 Working temperature: -25°C/+180°C
 ΔP of max calculation: 10 bar

DN		L (mm)	Kg
mm	inch		
25	1"	125	10,73
32	1 1/4"	130	12,18
40	1 1/2"	140	13,56
50	2"	150	15,9
65	2 1/2"	170	20,36
80	3"	180	25,16
100	4"	190	32,7
125	5"	325	63,5
150	6"	350	91,8
200	8"	400	140

Moteur électrique BERNARD CONTROLS BERNARD CONTROLS electric actuator		
TRI 400V/50Hz		MONO 230V/50Hz
Ref.		Ref.
BSD6249-B04PV0025		BSD6249-B24PV0025
BSD6249-B04PV0032		BSD6249-B24PV0032
BSD6249-B04PV0040		BSD6249-B24PV0040
BSD6249-B04PV0050		BSD6249-B24PV0050
BSD6249-B04PV0065		BSD6249-B24PV0065
BSD6249-B04PV0080		BSD6249-B24PV0080
BSD6249-B04PV0100		BSD6249-B24PV0100
BSD6249-B04PV0125		BSD6249-B24PV0125
BSD6249-B04PV0150		BSD6249-B24PV0150
BSD6249-B04PV0200		BSD6249-B24PV0200



ATEX sur demande / ATEX on request

BSD6239

ASA 150

Robinet à boisseau sphérique 2 pièces à brides - Inox - ASA 150

2-piece flanged ball valve - split body - Stainless steel - ASA 150

**BIENTÔT DISPONIBLE - AVRIL 2021
COMING SOON - APRIL 2021**



Corps : Acier inoxydable A351 CF8M
 Sphère : Acier inoxydable AISI 316
 Axe : Acier inoxydable AISI 316
 Etanchéité : PTFE
 Raccordement : A brides ASA 150
 Pression de service max : 20 bar
 Température de service :
 -25°C/+180°C

Body: Stainless steel A351 CF8M
 Ball: Stainless steel AISI 316
 Stem: Stainless steel AISI 316
 Seal: PTFE
 Connection: Flanged ASA 150
 Maximum working pressure: 20 bar
 Working temperature:
 -25°C/+180°C

A levier platine ISO Lever with ISO mounting plate				
DN		L (mm)	Kg	Ref.
mm	inch			
15	1/2"	108	2,08	BSD6239-02PV0015
20	3/4"	117	2,8	BSD6239-02PV0020
25	1"	127	3,73	BSD6239-02PV0025
32	1 1/4"	140	5,18	BSD6239-02PV0032
40	1 1/2"	165	6,56	BSD6239-02PV0040
50	2"	178	8,9	BSD6239-02PV0050
65	2 1/2"	190	13,4	BSD6239-02PV0065
80	3"	203	18,2	BSD6239-02PV0080
100	4"	229	25,7	BSD6239-02PV0100
150	6"	394	76,8	BSD6239-02PV0150
200	8"	457	125	BSD6239-02PV0200



**Poignée cadennassable
Lockable handle**

BSD6239-N03 | BSD6239-N07

Robinet à boisseau sphérique 2 pièces à brides - Inox - ASA 150 - à vérin pneumatique

2-piece flanged ball valve - split body - Stainless steel - ASA 150 - with pneumatic actuator



Corps : Acier inoxydable A351 CF8M
 Sphère : Acier inoxydable AISI 316
 Axe : Acier inoxydable AISI 316
 Etanchéité : PTFE
 Raccordement : A brides ASA 150
 Pression de service max : 20 bar
 Température de service : -25°C/+180°C
 ΔP de calcul maxi : 10 bar

Body: Stainless steel A351 CF8M
 Ball: Stainless steel AISI 316
 Stem: Stainless steel AISI 316
 Seal: PTFE
 Connection: Flanged ASA 150
 Maximum working pressure: 20 bar
 Working temperature: -25°C/+180°C
 ΔP of max calculation: 10 bar

DN		L (mm)	Kg
mm	inch		
15	1/2"	108	3
20	3/4"	117	4,18
25	1"	127	5,11
32	1 1/4"	140	6,56
40	1 1/2"	165	8,59
50	2"	178	10,93
65	2 1/2"	190	16,53
80	3"	203	22,8
100	4"	229	32,47
150	6"	394	90,05
200	8"	457	138,25

Vérin pneumatique Pneumatic actuator		
Double effet / Double-acting		Simple effet / Single-acting
Ref.		Ref.
BSD6239-N03PV0015		BSD6239-N07PV0015
BSD6239-N03PV0020		BSD6239-N07PV0020
BSD6239-N03PV0025		BSD6239-N07PV0025
BSD6239-N03PV0032		BSD6239-N07PV0032
BSD6239-N03PV0040		BSD6239-N07PV0040
BSD6239-N03PV0050		BSD6239-N07PV0050
BSD6239-N03PV0065		BSD6239-N07PV0065
BSD6239-N03PV0080		BSD6239-N07PV0080
BSD6239-N03PV0100		BSD6239-N07PV0100
BSD6239-N03PV0150		BSD6239-N07PV0150
BSD6239-N03PV0200		BSD6239-N07PV0200



ATEX sur demande / ATEX on request



Retrouvez nos options et accessoires pour vérin pneumatique TECOFI page 57 à 64 (électropositionneurs, boîtiers fin de course, filtres, positionneurs).

Find all options and accessories p.57 to 64 for pneumatic actuator (solenoid valve, limit switch box, filters, positioners).

BSD6239-N04 | BSD6239-N24

Robinet à boisseau sphérique 2 pièces à brides - Inox - ASA 150 - avec moteur TECOFI

2-piece flanged ball valve - split body - Stainless steel - ASA 150 - with TECOFI electric actuator



Corps : Acier inoxydable A351 CF8M
 Sphère : Acier inoxydable AISI 316
 Axe : Acier inoxydable AISI 316
 Etanchéité : PTFE
 Raccordement : A brides ASA 150
 Pression de service max : 20 bar
 Température de service : -25°C/+180°C
 ΔP de calcul maxi : 10 bar

Body: Stainless steel A351 CF8M
 Ball: Stainless steel AISI 316
 Stem: Stainless steel AISI 316
 Seal: PTFE
 Connection: Flanged ASA 150
 Maximum working pressure: 20 bar
 Working temperature: -25°C/+180°C
 ΔP of max calculation: 10 bar



ATEX sur demande / ATEX on request

				Moteur électrique TECOFI TECOFI electric actuator	
				TRI 400V/50/60Hz	MONO 230V/50/60Hz
DN		L (mm)	Kg	Ref.	Ref.
mm	inch				
25	1"	127	5,93	BSD6239-N04PV0025	BSD6239-N24PV0025
32	1 1/4"	140	7,38	BSD6239-N04PV0032	BSD6239-N24PV0032
40	1 1/2"	165	8,76	BSD6239-N04PV0040	BSD6239-N24PV0040
50	2"	178	11,1	BSD6239-N04PV0050	BSD6239-N24PV0050
65	2 1/2"	190	17,4	BSD6239-N04PV0065	BSD6239-N24PV0065
80	3"	203	22,2	BSD6239-N04PV0080	BSD6239-N24PV0080
100	4"	229	32,7	BSD6239-N04PV0100	BSD6239-N24PV0100
150	6"	394	84,6	BSD6239-N04PV0150	BSD6239-N24PV0150
200	8"	457	132,8	BSD6239-N04PV0200	BSD6239-N24PV0200

BSD6239-U04 | BSD6239-U24

Robinet à boisseau sphérique 2 pièces à brides - Inox - ASA 150 - avec moteur AUMA

2-piece flanged ball valve - split body - Stainless steel - ASA 150 - with AUMA electric actuator



Corps : Acier inoxydable A351 CF8M
 Sphère : Acier inoxydable AISI 316
 Axe : Acier inoxydable AISI 316
 Etanchéité : PTFE
 Raccordement : A brides ASA 150
 Pression de service max : 20 bar
 Température de service : -25°C/+180°C
 ΔP de calcul maxi : 10 bar

Body: Stainless steel
 Ball: Stainless steel AISI 316
 Stem: Stainless steel AISI 316
 Seal: PTFE
 Connection: Flanged ASA 150
 Maximum working pressure: 20 bar
 Working temperature: -25°C/+180°C
 ΔP of max calculation: 10 bar



ATEX sur demande / ATEX on request

				Moteur électrique AUMA AUMA electric actuator	
				TRI 400V/50Hz	MONO 230V/50Hz
DN		L (mm)	Kg	Ref.	Ref.
mm	inch				
25	1"	127	7,73	BSD6239-U04PV0025	BSD6239-U24PV0025
32	1 1/4"	140	9,18	BSD6239-U04PV0032	BSD6239-U24PV0032
40	1 1/2"	165	10,56	BSD6239-U04PV0040	BSD6239-U24PV0040
50	2"	178	12,9	BSD6239-U04PV0050	BSD6239-U24PV0050
65	2 1/2"	190	20,9	BSD6239-U04PV0065	BSD6239-U24PV0065
80	3"	203	25,7	BSD6239-U04PV0080	BSD6239-U24PV0080
100	4"	229	33,2	BSD6239-U04PV0100	BSD6239-U24PV0100
150	6"	394	76,8	BSD6239-U04PV0150	BSD6239-U24PV0150
200	8"	457	125	BSD6239-U04PV0200	BSD6239-U24PV0200

BSD6239-B04 | BSD6239-B24

Robinet à boisseau sphérique 2 pièces à brides - Inox - ASA 150 - avec moteur BERNARD CONTROLS

2-piece flanged ball valve - split body - Stainless steel - ASA 150 - with BERNARD CONTROLS electric actuator



Corps : Acier inoxydable A351 CF8M
 Sphère : Acier inoxydable AISI 316
 Axe : Acier inoxydable AISI 316
 Etanchéité : PTFE
 Raccordement : A brides ASA 150
 Pression de service max : 20 bar
 Température de service : -25°C/+180°C
 ΔP de calcul maxi : 10 bar

Body: Stainless steel A351 CF8M
 Ball: Stainless steel AISI 316
 Stem: Stainless steel AISI 316
 Seal: PTFE
 Connection: Flanged ASA 150
 Maximum working pressure: 20 bar
 Working temperature: -25°C/+180°C
 ΔP of max calculation: 10 bar



ATEX sur demande / ATEX on request

				Moteur électrique BERNARD CONTROLS BERNARD CONTROLS electric actuator	
				TRI 400V/50Hz	MONO 230V/50Hz
DN		L (mm)	Kg	Ref.	Ref.
mm	inch				
25	1"	127	10,73	BSD6239-B04PV0025	BSD6239-B24PV0025
32	1 1/4"	140	12,18	BSD6239-B04PV0032	BSD6239-B24PV0032
40	1 1/2"	165	13,56	BSD6239-B04PV0040	BSD6239-B24PV0040
50	2"	178	15,9	BSD6239-B04PV0050	BSD6239-B24PV0050
65	2 1/2"	190	20,36	BSD6239-B04PV0065	BSD6239-B24PV0065
80	3"	203	25,16	BSD6239-B04PV0080	BSD6239-B24PV0080
100	4"	229	32,7	BSD6239-B04PV0100	BSD6239-B24PV0100
150	6"	394	91,8	BSD6239-B04PV0150	BSD6239-B24PV0150
200	8"	457	140	BSD6239-B04PV0200	BSD6239-B24PV0200



BS6260

PN40

Robinet à boisseau sphérique passage intégral - modèle 3 pièces à brides PN40 à levier - Inox
 3-piece full bore flanged lever ball valve PN40 - Stainless steel



Corps : ASTM A351 CF8M
 Sphère : AISI 316
 Axe : AISI 316
 Étanchéité : PTFE chargé 15% verre
 Raccordement : à brides PN40
 Pression de service : 40 bar
 Température de service : -20°C/+180°C

Body: ASTM A351 CF8M
 Ball: AISI 316
 Stem: AISI 316
 Seal: 15% glass reinforced PTFE
 Connection: Flanged PN40
 Working pressure: 40 bar
 Working temperature: -20°C/+180°C

DN		L (mm)	Kg	Ref.
mm	inch			
15	1/2"	130	2,10	BS6260-0015
20	3/4"	150	2,80	BS6260-0020
25	1"	160	3,64	BS6260-0025
32	1 1/4"	180	5,50	BS6260-0032
40	1 1/2"	200	7,30	BS6260-0040
50	2"	230	10,00	BS6260-0050
65	2 1/2"	290	19,50	BS6260-0065
80	3"	310	25,10	BS6260-0080
100	4"	350	36,30	BS6260-0100



Poignée cadénassable
 Lockable handle



ROBINETS À BOISSEAU SPHÉRIQUE INOX 3 VOIES
 3-WAY STAINLESS STEEL BALL VALVES

BST6169 | BSL6169

BSP

Robinet à boisseau sphérique passage standard femelle BSP 3 voies à levier - Inox
 3-way standard bore female BSP threaded lever ball valve - Stainless steel



BST6169 : Lumière en T / T port
 BSL6169 : Lumière en L / L port

Corps : Inox EN 1.4408
 Sphère : AISI 316
 Axe : AISI 316
 Étanchéité : PTFE chargé 15% verre
 Raccordement : femelle BSP
 Pression de service max : 40 bar
 Température de service : -25°C/+180°C
 Platine ISO 5211 pour motorisation
 ATEX : Groupe II, catégorie 2G/2D zones 1 et 21, zones 2 et 22

Body: Stainless steel EN 1.4408
 Ball: AISI 316
 Stem: AISI 316
 Seal: 15% glass reinforced PTFE
 Connection: female BSP
 Maximum working pressure: 40 bar
 Working temperature: -25°C/+180°C
 ISO 5211 mounting plate for actuator
 ATEX: Group II, cat. 2G/2D zone 1 & 21, zone 2 & 22

BST6169				
DN		L (mm)	Kg	Ref.
mm	inch			
8	1/4"	75	0,70	BST6169-02PV0008
10	3/8"	75	0,70	BST6169-02PV0010
15	1/2"	75	0,75	BST6169-02PV0015
20	3/4"	85	0,94	BST6169-02PV0020
25	1"	100	1,39	BST6169-02PV0025
32	1 1/4"	122	2,91	BST6169-02PV0032
40	1 1/2"	131	3,66	BST6169-02PV0040
50	2"	158	6,31	BST6169-02PV0050

BSL6169				
DN		L (mm)	Kg	Ref.
mm	inch			
8	1/4"	75	0,70	BSL6169-02PV0008
10	3/8"	75	0,70	BSL6169-02PV0010
15	1/2"	75	0,75	BSL6169-02PV0015
20	3/4"	85	0,94	BSL6169-02PV0020
25	1"	100	1,39	BSL6169-02PV0025
32	1 1/4"	122	2,91	BSL6169-02PV0032
40	1 1/2"	131	3,66	BSL6169-02PV0040
50	2"	158	6,31	BSL6169-02PV0050



Poignée cadénassable
 Lockable handle



3 voies
 3-way

ROBINET BOISSEAU SPHÉRIQUE | BALL VALVE

BS6241L | BS6241T

A brides | Flanged

Robinet à boisseau sphérique à brides modèle 3 voies - Inox

3-way flanged ball valve - Stainless steel



BS6241L : Lumière en L / L port
BS6241T : Lumière en T / T port

Corps : Inox EN 1.4408
Sphère : ASTM A351 CF8M
Axe : AISI 316
Étanchéité : PTFE chargé 15% verre
Raccordement : A brides PN10/16
Pression de service max : 16 bar
Température de service : -30°C/+150°C
Platine ISO 5211
ATEX : Groupe II, catégorie 2G/2D zones 1 et 21, zones 2 et 22

Body: Stainless steel EN 1.4408
Ball: ASTM A351 CF8M
Stem: AISI 316
Seal: 15% glass reinforced PTFE
Connection: PN10/16 flanged
Maximum working pressure: 16 bar
Working temperature: -30°C/+150°C
ISO mounting plate 5211
ATEX: Groupe II, cat 2G/2D zone 1 & 21, zone 2 & 22

DN		L (mm)	Kg	Ref.
mm	inch			
50	2"	253	19,00	BS6241L-0050
65	2 1/2"	278	23,75	BS6241L-0065
80	3"	292,2	34,50	BS6241L-0080
100	4"	360	61,80	BS6241L-0100
125	5"	416	95,00	BS6241L-0125
150	6"	473	127,00	BS6241L-0150

DN		L (mm)	Kg	Ref.
mm	inch			
50	2"	253	19,00	BS6241T-0050
65	2 1/2"	278	23,75	BS6241T-0065
80	3"	292,2	34,50	BS6241T-0080
100	4"	360	61,80	BS6241T-0100
125	5"	416	95,00	BS6241T-0125
150	6"	473	127,00	BS6241T-0150



Levier cadenassable
Lockable lever

PVC | PVC



ROBINET À BOISSEAU SPHÉRIQUE PVC
PVC BALL VALVE

BS9540

PVC

Robinet à boisseau sphérique PVC femelle à coller - PN16

PVC solvent socket female ball valve - PN16



Corps : PVC
Joints : EPDM
Raccordement : Femelle à coller PVC
Pression de service max : 16 bar
DN10-50 : PN16
DN65-100 : PN10
Température de service max : +60°C (à 4 bar)
Consulter le passeport technique pour la courbe P/T°
Montage toute position

Body: PVC
Gasket: EPDM
Connection: PVC Solvent socket female
Maximum working pressure: 16 bar
DN10-50: PN16
DN65-100: PN10
Maximum working temperature: +60°C (at 4 bar)
Consult the technical data sheet for the P/T° curve
Design to work in any position



DN		Ø ext. Tuyau / Tube	L (mm)	Kg	Ref.
mm	inch				
10	3/8"	16	95	0,17	BS9540-0016
15	1/2"	20	95	0,166	BS9540-0020
20	3/4"	25	104	0,221	BS9540-0025
25	1"	32	116	0,33	BS9540-0032
32	1 1/4"	40	133	0,491	BS9540-0040
40	1 1/2"	50	149	0,834	BS9540-0050
50	2"	63	167	1,233	BS9540-0063
65	2 1/2"	75	225	2,749	BS9540-0075
80	3"	90	146	3,91	BS9540-0090
100	4"	110	309	7,51	BS9540-0110



Variante joint FPM (VITON) nous consulter.
Variante raccordement à visser BSP, nous consulter.

Contact us for FPM (VITON) gasket.
Contact us for coupling with BSP screw connection.



ROBINETS À BOISSEAU SPHÉRIQUE | BALL VALVES



GÉNÉRALITÉS

Maintenir le robinet ou l'entraîner en rotation du côté du vissage seulement : par le 6 pans ; au moyen d'une clé plate ou d'une clé à molette.

Éviter d'utiliser des pinces ou des clés à griffes qui peuvent détériorer le revêtement externe.

Ne jamais pincer les corps des robinets dans un étau.

Serrer modérément l'appareil de robinetterie ou le raccord. Ne pas bloquer avec des rallonges de clé (rupture des bouts ou déformation permanente du corps).

D'une manière générale et pour toute la petite robinetterie équipant le bâtiment, ne pas dépasser le couple de 30 Nm à l'occasion d'un serrage.

Lors d'un pré-montage, le robinet ne doit pas supporter la tuyauterie.

Sauf en cas de nécessité absolue, ne pas démonter les éléments des appareils de robinetterie neufs. Chaque appareil a subi les épreuves hydrauliques ou pneumatiques de réception qui garantissent un assemblage correct des éléments et l'étanchéité de l'ensemble.

Le raccordement d'un robinet à boisseau sphérique étant généralement assuré par un filetage «GAZ», étanche dans le filet (filetage du tube conique, filetage du manchon cylindrique), ces filetages doivent répondre aux prescriptions de la norme NF E 03-004, elle-même conforme à ISO/R7. Toutefois, les longueurs taraudées des manchons étant souvent plus petites que les longueurs théoriques ISO/R7, ainsi que l'admet la norme NF E 03-004, il est indispensable :

- de limiter la longueur filetée du tube ;
- d'employer un produit (ruban PTFE ou similaire) assurant l'étanchéité du raccordement ;
- de vérifier que l'extrémité du tube ne bute pas sur l'épaulement du siège (jeu obligatoire : 1 mm minimum).*

GENERALITIES

Maintain the valve or drive it in rotation only on the screwed side: by the 6-sided end with a plane wrench or an adjustable wrench.

Avoid using grips or hook spanners which can damage the external coating.

Never grip the valve bodies in a vice.

Tighten moderately, when screwing, valves and fittings.

Do not block with key extensions (breaking of the butts or permanent buckling of the body).

In a general manner, and for all the small valves and fittings equipping the building, not to exceed the tightening torque of 30 Nm.

When beginning installation, the valve should not support the piping.

Except in the event of absolute necessity, do not dismantle the elements of the new valves. Each apparatus underwent hydraulic or pneumatic tests which guarantee a correct assembly of the elements and the overall tightness.

Connection of a ball valve being generally ensured by a threading «BSP», water tight in the threads (threading of the conical tube, threading of the split coupling), these threads must fulfill the criteria of the standard NF E 03-004, itself conforms to ISO/R7. Nevertheless, the tapped lengths of the sleeves being often smaller than theoretical lengths ISO/R7, which the standard NF E 03-004 permits, it is essential to:

- Limit the threaded length of the tube,
- Use a product (PTFE ribbon or similar) ensuring connection water tightness,
- Check that the tube extremity does not butt against the shoulder of the seat (required clearance: 1mm minimum).

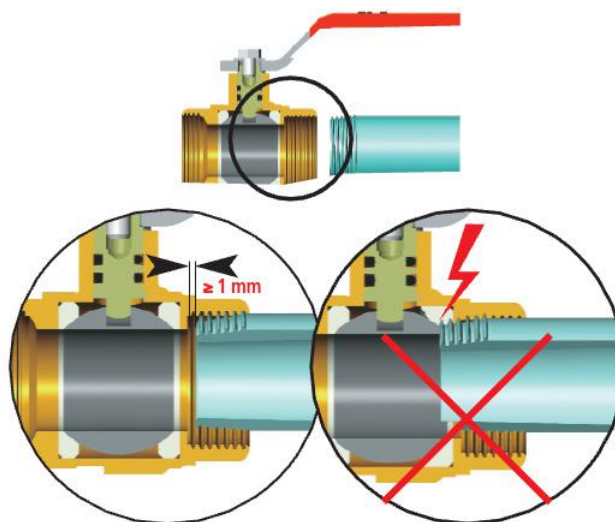



MESURE | CONTRÔLE MEASURE | CONTROL

**THERMOMÈTRES
THERMOMETERS**

293 > 294

**MANOMÈTRES
PRESSURE GAUGES**

295 > 296

**ROBINETS
VALVES**

297 > 300

**DÉTECTEUR DE NIVEAU
LEVEL SWITCH**

301

**COMPTEURS
FLOW METERS**

302 > 303

**DÉBITMÈTRE
ÉLECTROMAGNÉTIQUE
ELECTROMAGNETIC
FLOW METER**

304 > 305

**STABILISATEUR
D'ÉCOULEMENT
SUSTAINING FLOW VALVE**

306

**CONTRÔLEURS DE
CIRCULATION
SIGHT GLASSES**

307

MESURE - CONTRÔLE - NIVEAU

MEASURES | CONTROLS | GAUGES



THERMOMÈTRES

Ils permettent à partir d'appareils spécifiques (thermomètres, thermostat, capteur de température) de mesurer une température.

THERMOMETERS

They are specific devices (thermometers, thermostats, temperature sensors) measure temperatures.

MANOMÈTRES

Les mesures de pression peuvent être effectuées à partir d'appareils comme les manomètres, pressostats, capteur de pression.

PRESSURE GAUGES

Pressure measurements can be carried out by devices like pressure gauges, pressure switches and pressure sensors.

DÉTECTEURS DE NIVEAU

Sa fonction est d'indiquer à l'extérieur d'une cuve, le niveau présent à l'intérieur.

LEVEL SWITCH

Its purpose is to show, on the outside of a tank, the present level inside.

COMPTEURS D'EAU

Ils permettent de relever à distance la quantité d'eau passée au travers d'une canalisation.

WATER METERS

From a distance they allow you to measure the amount of water passing through pipes.

DÉBITMÈTRES

Ils désignent une quantité écoulee par facteur temps. Les différents appareils pour mesurer un débit sont les débitmètres, les compteurs volumétriques...

FLOWMETERS

They describe the amount flowing through an area for a given time period. Different devices for measuring a flow are flowmeters, volumeters, etc.

CONTRÔLEURS DE CIRCULATION

Ils ont pour fonction de visualiser la circulation d'un fluide. Le contrôle se fait soit par transparence pour des liquides colorés, soit à l'aide d'indicateur mécanique tel qu'une bille, une palette, une hélice...

FLOW INDICATORS

They aim to show the flow of a fluid. They check the flow either via transparency for colored liquids, or with the help of a mechanical indicator such as a ball, a blade or a propeller.





**THERMOMÈTRES
THERMOMETERS**

TB1101AL

Thermomètre industriel à boîtier modèle droit
Straight type industrial thermometer



Boîtier : Aluminium anodisé couleur laiton
Plonge : Laiton
Raccordement : Laiton mâle BSP 1/2»
Pression max : 16 bar
Graduation : -30/+50°C; 0/+60°C;
0/+120°C; 0/+200°C
Normes : selon DIN 16195
(M) : Moyen modèle
(G) : Grand modèle



**Idéal HVAC
Perfect for HVAC**

Casing: Brass-colored anodized aluminium
Bulb: Brass
Connection: Brass male BSP 1/2"
Max Pressure: 16 bar
Scale: -30/+50; 0/+60; 0/+120; 0/+200
Standards: DIN 16195
(M): Medium type
(G): Large type

Hauteur Height	L Plonge bulb (mm)	Kg	Ref.
150 (M)	63	0,19	TB1101AL063M-0060 TB1101AL063M-3050 TB1101AL063M-0120
200 (G)	63	0,30	TB1101AL063G-0060 TB1101AL063G-3050 TB1101AL063G-0120
150 (M)	100	0,30	TB1101AL100M-0060 TB1101AL100M-3050 TB1101AL100M-0120
200 (G)	100	0,32	TB1101AL100G-0060 TB1101AL100G-0120

TB1102AL

Thermomètre industriel à boîtier modèle équerre
Angle type industrial thermometer



Boîtier : Aluminium anodisé couleur laiton
Plonge : Laiton
Raccordement : Laiton mâle BSP 1/2»
Pression max : 16 bar
Graduation : -30/+50°C; 0/+60°C;
0/+120°C; 0/+200°C
(M) : Moyen modèle
(G) : Grand modèle



**Idéal HVAC
Perfect for HVAC**

Casing: Brass-colored anodized alu
Bulb: Brass
Connection: Brass male BSP 1/2"
Max Pressure: 16 bar
Scale: -30/+50; 0/+60; 0/+120; 0/+200
(M): Medium type
(G): Large type

Hauteur Height	L Plonge bulb (mm)	Kg	Ref.
150 (M)	63	0,19	TB1102AL063M-0060 TB1102AL063M-3050 TB1102AL063M-0120
200 (G)	63	0,30	TB1102AL063G-0060 TB1102AL063G-3050 TB1102AL063G-0120
150 (M)	100	0,30	TB1102AL100M-0060 TB1102AL100M-3050 TB1102AL100M-0120
200 (G)	100	0,32	TB1102AL100G-0060 TB1102AL100G-3050 TB1102AL100G-0120

TC7100

Thermomètre de chauffage à cadran plonge arrière
Heating dial thermometer back bulb



Boîtier : Acier chromé / Voyant verre
Raccordement : Laiton mâle BSP 1/2"
(DN 40 3/8")
Pression max : 6 bar
Graduation : 0/120°C
Autres °C : -30/+50; 0/+60; 0/+120;
0/+200
Classe 2



**Idéal HVAC
Perfect for HVAC**

Casing: Chromed steel / Glass indicator
Connection: Brass male BSP 1/2"
(DN 40 3/8")
Pressure: 6 bar
Scale: 0/120°C
Other °C: -30/+50; 0/+60; 0/+120; 0/+200
Class 2

DN	L Plonge bulb (mm)		Kg	Ref.
	mm	inch		
63	2"1/2	40	0,05	TC7100AL063040-120
63	2"1/2	60	0,09	TC7100AL063060-120
63	2"1/2	100	0,20	TC7100AL063100-120
80	3"	40	0,05	TC7100AL080040-120
80	3"	63	0,09	TC7100AL080060-120
80	3"	100	0,20	TC7100AL080100-120
100	4"	40	0,05	TC7100AL100040-120
100	4"	63	0,09	TC7100AL100060-120
100	4"	100	0,20	TC7100AL100100-120



**Plongeur horizontal ø9mm livré avec doigt de gant laiton ø11mm PN6
Horizontal plunger ø9mm supplied with immersion sleeve ø11mm PN6**



**Le doigt de gant est utilisé pour permettre un changement ou faciliter la maintenance du thermomètre grâce à un démontage sans purge du système. Il protège également l'instrument en cas de pression élevée supérieure à 16 bar.
An immersion sleeve is used to change or facilitate maintenance of thermometers, allowing disassembly without purging the system. It also protects instruments in the case of the pressure raising above 16 bar.**

TC7101

Thermomètre de chauffage à cadran plonge verticale
Heating dial thermometer vertical bulb



Boîtier : Acier zingué et lunette Inox
Raccordement : Laiton mâle BSP 1/2"
Pression max : 6 bar
Graduation : 0/120°C
Autres °C : -30/+50; 0/+60; 0/+120;
0/+200
Classe 2.5

Casing: Chromed steel
Connection: Brass male BSP 1/2"
Pressure: 6 bar
Scale: 0/120°C
Other °C: -30/+50; 0/+60; 0/+120; 0/+200
Class 2.5

DN	L Plonge bulb (mm)		Kg	Ref.
	mm	inch		
80	3"	40	0,10	TC7101AC080045-120
80	3"	63	0,12	TC7101AC080063-120
80	3"	100	0,17	TC7101AC080100-120
100	4"	63	0,12	TC7101AC100063-120
100	4"	100	0,17	TC7101AC100100-120



**Plongeur vertical ø9mm livré avec doigt de gant laiton ø11mm PN6
Horizontal plunger ø9mm supplied with brass immersion sleeve ø11mm PN6**

PT100L-3FILS

Sonde de température électrique 3 fils
Temperature sensor 3 wires



Plonge : Inox 316 Ti
Classe A selon IEC 60751
Température de service : -50°C / +250°C
Entrée : M20 x 1.5
Sortie : 3 fils
Indice de protection : IP65
Pression de service max : 25 bar



Idéal biogaz
Perfect for biogas

Bulb: Stainless steel 316 Ti
Class A according to IEC 60751
Working temperature: -50°C / +250°C
Entry: M20 x 1.5
Output: 3 wires
Protection: IP65
Maximum working pressure: 25 bar



ATEX sur demande / ATEX on request



Plonge / Bullo L (mm)	Ref.
50	PT100L-3FILS-050
63	PT100L-3FILS-063
100	PT100L-3FILS-100
150	PT100L-3FILS-150

PT100L-2FILS

Sonde de température électrique 2 fils 4-20mA
Temperature sensor 2 wires 4-20mA



Plonge : Inox 316 Ti
Classe A selon IEC 60751
Température de service : -50°C / +250°C
Protection IP65
Entrée : M20 x 1.5
Sortie : 2 fils 4-20mA
Indice de protection : IP65
Pression de service max : 25 bar



Idéal biogaz
Perfect for biogas

Bulb: Stainless steel 316 Ti
Class A according to IEC 60751
Working temperature: -50°C / +250°C
IP65 protection
Entry: M20 x 1.5
Output: 2 wires 4-20mA
Protection: IP65
Maximum working pressure: 25 bar



ATEX sur demande / ATEX on request



Plonge / Bullo L (mm)	Ref.
50	PT100L-2FILS-050
63	PT100L-2FILS-063
100	PT100L-2FILS-100
150	PT100L-2FILS-150



Raccordement de la sonde avec le convertisseur sortie 4-20mA
Connection of the sensor with the 4-20mA output converter

PT100L-RACC

Raccord coulissant
Sliding connector



Matière : Inox 316 Ti
Raccordement : 1/2"G

Material: Stainless steel 316 Ti
Connection: 1/2"G

DN	Ref.
1/2G	PT100L-RACC



Permet d'adapter la longueur de la sonde
Allows the length of the sensor to be adapted

PT100L-DOIGT

Doigt de gant
Immersion sleeve



Matière : Inox 316 Ti
1/2"G Ø8mm int.

Material: Stainless steel 316 Ti
1/2"G Ø8mm int.

DN	L	Ref.
1/2G	40	PT100L-DOIGT-040
1/2G	63	PT100L-DOIGT-063
1/2G	100	PT100L-DOIGT-100
1/2G	160	PT100L-DOIGT-160



Autre matière sur demande
Other material on request





**MANOMÈTRES
PRESSURE GAUGES**

MANOMÈTRES | PRESSURE GAUGE

Dans la technique des mesures de pression, les manomètres sont, du fait de leur solidité et de leur facilité d'utilisation, très répandus.

Les manomètres possèdent des organes moteurs qui, sous l'effet d'une pression, se déforment élastiquement.

Les organes moteurs sont fabriqués normalement en alliage de cuivre ou d'acier ou, pour des applications particulières de mesure, en matériaux spéciaux.

On différencie les manomètres d'après le principe de mesure et selon la forme de l'organe moteur.

Choisir le bon manomètre

- > Quelle pression mesurez-vous?
- > Quel fluide est concerné ?
- > Quel raccord avez-vous (1/4" Gaz ø63 / 1/2" Gaz ø100) ?
- > Raccord vertical (RV) ou raccord axial (RA)?

For pressure measurement technology, pressure gauges are very common due to their strength and ease of use.

Pressure gauges have driving members which, under the effect of pressure, elastically deform.

The components are normally made from brass or SS, for special measurement applications, special materials are available.

We differentiate pressure gauges according to the principle of measurement and according to the shape of the driving component.

Choose the right pressure gauge

- > What kind of pressure do you want to measure?
- > Which kind of fluid is involved?
- > What type of connection do you have?
- > Vertical connection or axial connection?

Graduation PSI sur demande / PSI graduation on request

MA5100

Manomètre à raccord vertical boîtier sec - tube de bourdon et raccord laiton

Pressure gauge with vertical connection with dry casing - bourdon tube pressure gauge with brass connection



Boîtier : DN 63 ABS / DN 80 et 100 acier
 Mécanisme : Alliage cuivreux
 Raccordement : Laiton mâle BSP
 Température max : -20°C/+60°C
 Graduation : 0/16 bar - autres sur demande entre -1 à +60 bar

Casing: DN 63 ABS / DN 80 et 100 steel
 Mechanism: Brass
 Connection: Brass male BSP
 Max Temperature: -20°C/+60°C
 Scale: 0/16 bar - other scales on request between -1 up to +60 bar

Ø	Raccordement connection	Kg	Ref.
63	1/4"	0,25	MA510063-000/006
			MA510063-000/010
			MA510063-000/016
			MA510063-000/025
100	1/2"	0,97	MA5100100-000/006
			MA5100100-000/010
			MA5100100-000/016
			MA5100100-000/025
			MA5100100-000/040

MA5102

Manomètre à raccord vertical boîtier à bain de glycérine - tube de bourdon et raccord laiton

Pressure gauge with vertical connection and glycerin filled - bourdon tube pressure gauge with brass connection



Boîtier : Inox
 Mécanisme : Alliage cuivreux
 Raccordement : Laiton mâle BSP
 Température max : -20°C/+60°C
 Graduation : 0/16 bar - autres sur demande entre 0 à +60 bar
 Conforme à la norme EN 837-1

Casing: Stainless steel
 Mechanism: Brass
 Connection: Brass male BSP
 Max Temperature: -20°C/+60°C
 Scale: 0/16 bar - other scales on request between 0 up to +60 bar
 According to EN 837-1

Ø	Raccordement connection	Kg	Ref.
63	1/4"	0,25	MA5102063-000/006
			MA5102063-000/010
			MA5102063-000/016
			MA5102063-000/025
100	1/2"	0,97	MA5102100-000/006
			MA5102100-000/010
			MA5102100-000/016
			MA5102100-000/025
			MA5102100-000/040

MA6100

Manomètre à raccord vertical boîtier tout Inox sec remplissable

All Stainless steel dry refillable pressure gauge with vertical connection



Corps : Inox 304
 Mécanisme : Tube de bourdon et raccord en Inox 316L
 Raccordement : Inox 316L mâle BSP
 Température max : +200°C
 Graduation : 0/16 bar - autres sur demande 0,6 à +60 bar
 Option : Glycérine (sur demande)
 Conforme à la norme EN 837-1

Casing: Stainless steel
 Mechanism: Stainless steel
 Connection: Stainless steel male BSP
 Max Temperature: +200°C
 Scale: 0/16 bar - other one on request 0,6 up to +60 bar
 Option: Glycerine (on request)
 According to EN 837-1



**Idéal vapeur, eau
For steam, water**

Ø	Raccordement connection	Kg	Ref.
63	1/4"	0,16	MA610063-000/006
			MA610063-000/010
			MA610063-000/016
			MA610063-000/025
100	1/2"	0,6	MA6100100-000/006
			MA6100100-000/010
			MA6100100-000/016
			MA6100100-000/025
			MA6100100-000/040

Certificat d'étalonnage possible
Calibration certificate possible

MA6105

Manomètre à contact

Pressure gauge with contact



Construction : Inox
Modèle à glycérine
Cadran : Plastique
Raccordement : Vertical mâle 1/2"G
Protection : IP44
1 contact

Construction: Stainless steel
Glycerine type
Dial: Plastic
Connection: Male vertical 1/2"G
Protection: IP44
1 contact

DN		Ø	Ref.
mm	inch		
15	1/2"	100	MA6105100-000/006
15	1/2"	100	MA6105100-000/010

MA6106 | MA6107

Manomètre à capsule pour faible pression

Gas capsule pressure gauge for low pressure



Boîtier : Inox 304
Raccord vertical laiton mâle
Cadran sec
Température de service : 0/+60°C
Pression : 0/600mbar

Case: Stainless steel 304
Brass male vertical connection
Dry dial
Working temperature: 0/+60°C
Pressure: 0/600mbar

DN		Ø	Class	Ref.
mm	inch			
8	1/4"	63	2,5	MA6106-000/060
8	1/4"	63	2,5	MA6106-000/100
8	1/4"	63	2,5	MA6106-000/250
8	1/4"	63	2,5	MA6106-000/400
8	1/4"	63	2,5	MA6106-000/600

DN		Ø	Class	Ref.
mm	inch			
15	1/2"	100	1,6	MA6107-000/060
15	1/2"	100	1,6	MA6107-000/100
15	1/2"	100	1,6	MA6107-000/250
15	1/2"	100	1,6	MA6107-000/400
15	1/2"	100	1,6	MA6107-000/600



Spécial gaz basse pression
Special for low pressure gas

MAE9000

Manomètre digital

Digital pressure gauge



Boîtier : Polycarbonate Ø76,5mm
Protection IP65
Ecran : 40 x 30mm
Température d'utilisation : -20°C / +85°C
Classe : 0,25
Alimentation : 2 piles lithium 3,6V

Case: Polycarbonate Ø76,5mm
IP65 protection
Screen: 40 x 30 mm
Working conditions: -20°C / +85°C
Class: 0,25
Power: 2 x 3,6V lithium batteries

DN		Ø	Kg	Ref.
mm	inch			
15	1/2"	76,5	0,3	MAE9000-0/16b
15	1/2"	76,5	0,3	MAE9000-0/250b

MS6100G100

Manomètre tout Inox sec remplissable monté sur séparateur - raccord fileté

Stainless steel dry refillable pressure gauge with diaphragm seal - threaded connection



Manomètre corps : Inox 316L
Membrane inox 316L raccord fileté 1/2"G
Température de service :
-10°C / + 200°C
Pression max de service : 40 bar

Manometer: Stainless steel 316L
Stainless steel 316L diaphragm male
threaded connection 1/2"G
Working temperature: -10°C / + 200°C
Max working pressure: 40 bar

DN		Ø	Ref.
mm	inch		
15	1/2"	100	MS6100G100-15-00/10



Monté et testé !
Assembled and tested!



Idéal STEP - Compatible fluides pâteux grâce au séparateur permettant de ne pas obstruer le tube de bourdon.
For WTP - Compatible with pasty fluids thanks to the separator so as not to obstruct the drone tube.





**ROBINETS
VALVES**

BC1100

Robinet à boisseau pour manomètre mâle / femelle BSP - PN16
Male / female BSP plug valve for pressure gauge - PN16



Corps : Laiton
Pression max : 16 bar
Température max : +80°C
Raccordement : Mâle femelle BSP
Avec trou de décompression

Body: Brass
Maximum pressure: 16 bar
Max Temperature: +80°C
Connection: Male female BSP
With air relief hole

DN		L	Kg	Ref.
mm	inch			
8	1/4"	46	0,13	BC1100-0008
10	3/8"	50	0,14	BC1100-0010
15	1/2"	56	0,18	BC1100-0015

BC1103

Robinet à boisseau pour manomètre
Ball valve for pressure gauge



Corps : Laiton nickelé
Température max : +80°C
Raccordement : Mâle femelle BSP
Avec trou de décompression

Body: Nickel plated brass
Max Temperature: +80°C
Connection: Male female BSP
With air relief hole

DN		PN	Ref.
mm	inch		
8	1/4"	25	BC1103-0010
15	1/2"	40	BC1103-0015

RP1690

Laiton | Brass

Robinet à pointe pour manomètre
Brass needle valve for pressure gauge



Corps : Laiton
Pointeau : Acier
Raccord : Mâle femelle BSP
Pression max : 250 bar
Température max : +120°C
Avec trou de décompression

Casing: Brass
Needle: Steel
Ends: Male female BSP
Max Pressure: 250 bar
Max Temperature: +120°C
With air relief hole

DN		L	Kg	Ref.
mm	inch			
15	1/2"	100	0,58	RP1690-0015

MAN2V-FF | MAN2V-MF

Manifold 2 voies NPT
NPT 2-way manifold



MAN2V-FF : Raccordement 1/2" femelle NPT
MAN2V-MF : Raccordement 1/2" mâle / femelle NPT

MAN2V-FF : Connection 1/2" female NPT
MAN2V-MF : Connection 1/2" male / female NPT

Corps : Inox 316L
Tige : Inox 316L
Garniture : PTFE/Graphite
Purge : 1/4" femelle NPT with cap

Body: Stainless steel 316L
Stem: Stainless steel 316L
Packing: PTFE/Graphite
Drain plug: 1/4" female NPT

DN		L	Ref.
mm	inch		
15	1/2"	117	MAN2V-FF
15	1/2"	117	MAN2V-MF

MESURE / CONTRÔLE
MEASURE / CONTROL

RP5690

Acier | Steel

Robinet à pointeau PN400

Steel needle valve PN400



Corps : Acier
 Pointeau : Inox
 Presse étoupe : PTFE
 Pression de service max : 400 bar
 Température de service max : +200°C
 Raccordement : Male / Ecrou femelle BSP

Body: Steel
 Needle: Stainless steel
 Packing: PTFE
 Max working pressure: 400 bar
 Max working temperature: +200°C
 Connection: Male BSP / Nut female BSP

DN		L	Kg	Ref.
mm	inch			
15	1/2"	100	0,60	RP5690-0015

RP6690

Inox | Stainless steel

Robinet à pointeau PN400

Stainless steel needle valve PN400



Corps : Inox
 Pointeau : Inox
 Presse étoupe : PTFE
 Pression de service maxi : 400 bar
 Température de service max : +200°C
 Raccordement : Male BSP / Ecrou femelle BSP

Body: Stainless steel
 Needle: Stainless steel
 Packing: PTFE
 Max working pressure: 400 bar
 Max working temperature: +200°C
 Connection: Male BSP / Nut female BSP

DN		L	Kg	Ref.
mm	inch			
15	1/2"	100	0,6	RP6690-0015



ATEX sur demande / ATEX on request

AILETTE-15

Ailette de refroidissement pour capteur

Cooling tower



Construction : Inox 303
 Raccordement : 1/2" Mâle/Femelle

Construction: Stainless steel 303
 Connection: 1/2" Male/Female

DN		L	Kg	Ref.
mm	inch			
15	1/2"	123	0,325	AILETTE-15





Siphon | Syphon

- ✓ Refroidit la température avant le contact au manomètre (jusqu'à 100°C maximum).
- ✓ Protège contre les pulsations.
- ✓ A l'intérieur du siphon se produit une condensation qui empêche le fluide surchauffé de pénétrer dans le manomètre.
- ✓ Remplir le siphon avant montage du manomètre.

- ✓ Cools the temperature before contact with the pressure gauge (up to 100°C maximum).
- ✓ Protects against pulses.
- ✓ The interior of the syphon forms condensation that stops overheated fluid from entering the manometer.
- ✓ Fill the syphon before mounting the manometer.

SC5691

Acier | Steel

Siphon corps de chasse M/F - Acier
Steel syphon M/F



Construction : Acier
Raccordement : Mâle/Femelle
Pression de service :
100 bar à 120°C
63 bar à 400°C

Construction: Steel
Connection: Male/Female
Working pressure:
100 bar at 120°C
63 bar at 400°C

DN		Ref.
mm	inch	
15	1/2"	SC5691-0015

SC6691

Inox | Stainless steel

Siphon corps de chasse M/F - Inox
Stainless steel syphon M/F



Construction : Inox 316 Ti
Raccordement : Mâle/Femelle
Pression de service : 100 bar à 120°C / 63 bar à 400°C

Construction: Stainless steel 316 Ti
Connection: Male/Female
Working pressure: 100 bar at 120°C / 63 bar at 400°C

DN		Ref.
mm	inch	
15	1/2"	SC6691-0015



Pensez au corps de chasse dans vos réseaux vapeur !
Think about a syphon in your steam network!

INSTRUCTION DE MONTAGE MANOMÈTRE | INSTALLATION INSTRUCTIONS FOR PRESSURE GAUGES

Précautions | Precautions

Avant tout montage et mise en service d'un manomètre ou d'un manomètre avec séparateur, vous devez vérifier l'adéquation de l'instrument avec les conditions de service (gamme de pression et température de travail, compatibilité des matériaux), afin de prendre toutes les mesures nécessaires à un bon fonctionnement, en toute sécurité.
Before mounting and operating a pressure gauge or a pressure gauge with separator, you must check that the instrument meets the operating conditions (pressure range and working temperature, compatibility of materials), in order to take all the measures necessary for safe and proper operation.

Type de montage | Mounting type

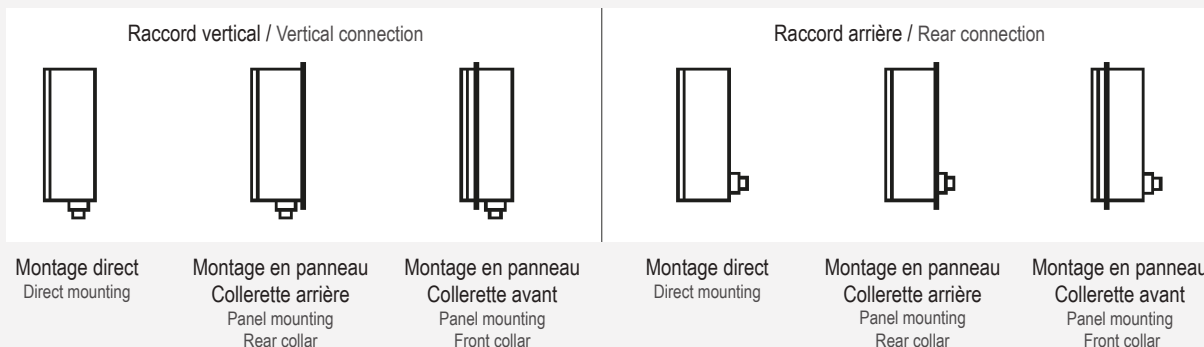

Position de montage Mounting position

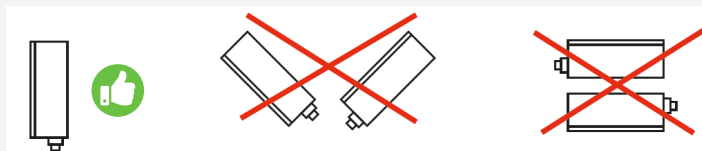

Raccordement : Filetage cylindrique : L'étanchéité sera assurée par un joint plat (selon EN 837-1) ou des joints profilés à choisir selon la nature, la température et la pression du fluide.

Filetage conique : L'étanchéité sera assurée par un rajout autour du filetage d'un ruban d'étanchéité (voir EN 837-2) tel que le ruban PTFE.

Bride : Respecter les consignes de montage qui correspondent à la norme de définition de la bride.

Montage : Le vissage sera efficace si vous utilisez une clé sur les six pans et en aucun cas en utilisant le corps du manomètre. Dès la mise sous pression de l'installation (ouvrir doucement les vannes pour éviter un coup de bélier) vérifiez l'étanchéité de l'ensemble. Si le manomètre est équipé d'un dispositif de décharge de surpression (pastille d'éclatement à l'arrière du boîtier), il ne devra pas être installé à moins de 20 mm de tout obstacle.

Chocs mécaniques : Les manomètres ne doivent pas être soumis à des chocs mécaniques, même accidentels. Si l'installation présente un risque de créer des chocs sur le manomètre, ce dernier devra être déporté (capillaire à rajouter) et installé en un lieu sécurisé.

Vibrations : Les manomètres ne doivent pas être soumis à des vibrations. Si l'installation engendre de faibles vibrations, utiliser un manomètre à bain d'huile (le liquide minimise l'effet des vibrations sur le mouvement mécanique). Dans le cas de vibrations fortes ou continues, prévoir de déporter le manomètre (capillaire à rajouter) pour l'installer sur un support stable.

Régime de battement de la pression : Ce type de régime écourt la vie du capteur et du mouvement mécanique. Il est aisément réparable par le déplacement en va et vient de l'aiguille sur une grande étendue (pression instable variant par à-coups). Il faut réduire cet effet de battement en installant un amortisseur entre le manomètre et la prise de pression.

Pression excessive : Des excès de pression répétés (en deçà de la pression limite acceptable) peuvent écourter la vie de l'instrument (fatigue du capteur) et même provoquer sa destruction (dynamique violente de l'augmentation de pression). Il faut donc installer un manomètre dont le maximum de l'échelle soit plus élevé que la pression maximale de service (ou accidentelle). L'effet des excès de pression peut être diminué en insérant dans le montage un clapet de décharge.

Température : Température ambiante : Il est difficile de protéger un manomètre d'une température ambiante trop élevée ou trop basse. Une solution est de déporter le manomètre pour l'éloigner de la source de chaleur ou de froid. Pour les manomètres de grande précision, Classe 0.6 où il sera nécessaire d'apporter une correction à la lecture dès lors que la température ambiante est différente de la température de référence (à laquelle sont gradués les manomètres) i.e. 20 °C +/- 2 °C (sauf spécification contraire).

Température du fluide : Le manomètre sera protégé d'une température excessive du fluide (ou qui pourrait provoquer une condensation du gaz dans le capteur) en intercalant un siphon ou un refroidisseur prévu à cet effet. Le fluide qui est à l'intérieur du capteur ne doit pas y cristalliser ou y geler. Pour des conditions de service extrêmes il est recommandé de monter le manomètre sur un séparateur qui l'isolera du fluide. Le liquide de remplissage et les matériaux seront choisis avec précaution.

Certificat de non-contamination : Certaines applications requièrent l'absence d'un contaminant donné pour les parties en contact avec le fluide sans. Dans ce cas il est de la responsabilité de l'installateur de s'assurer que le matériel est bien certifié pour les exigences du process avant de le monter.

Mise en service : Comme pour toute installation, la mise en pression doit être réalisée en douceur pour éviter les pressions excessives ou les variations brusques de température. Pour cette raison il est conseillé d'ouvrir progressivement les vannes d'arrêt.

Maintenance : La sécurité de l'installation dépend aussi du bon état des manomètres. Les indications du ou des manomètres doivent être fiables. En cas d'une lecture laissant un doute sur la qualité de la mesure, il faut remplacer le manomètre ou le vérifier et le cas échéant le re-étalonner. Des tests d'étalonnage doivent être effectués régulièrement. Ces tests doivent être réalisés par du personnel qualifié.

Les séparateurs doivent être régulièrement (chaque semestre) déposés du process (le manomètre ne doit pas être désolidarisé) pour procéder au nettoyage de la membrane (côté process). Utiliser un solvant adéquat en évitant tout objet solide pouvant détériorer la membrane.

Connection: Cylindrical thread: Tightness will be ensured with a flat gasket (according to EN 837-1) or with profile gaskets to choose according to the nature, temperature and pressure of the fluid.

Conical thread: Tightness will be ensured by adding sealing tape around the thread (see EN 837-2) such as PTFE.

Flange: Observe the mounting instructions which correspond to flange standards.

Mounting : Screwing should be done with a hexagon wrench and in no case done with the body of the pressure gauge. As soon as the system is pressurized, gently open the valves to avoid water hammer and check the tightness of the assembly. If the pressure gauge is fitted with an overpressure relief device (burst pad on the back of the housing), it must not be installed within 20 mm of any obstacle.

Mechanical shocks: Manometers must not be subjected to mechanical shocks, even accidentally. If the installation presents a risk of creating shocks on the pressure gauge, it must be removed (capillary to be added) and installed in a secure place.

Vibrations: The pressure gauges must not be subjected to vibrations. If the installation generates weak vibrations, use an oil bath pressure gauge (the liquid minimizes the effect of vibrations on the mechanical movement). In the case of strong or continuous vibrations, plan to move the pressure gauge (capillary to be added) to install it on a stable support.

Pressure flapping regime: This type of shortens the life of the sensor and mechanical movement. It can be easily repaired by moving the needle back and forth over a large span (unstable pressure varying in spurts). This pulsing effect must be reduced by installing a shock absorber between the pressure gauge and the pressure tap.

Excessive pressure: Repeated excess pressure (below the acceptable limit pressure) can shorten the life of the instrument (sensor fatigue) and even cause its destruction (violent and dynamic pressure increase). It is therefore necessary to install a pressure gauge whose maximum of the scale is higher than the maximum operating (or accidental) pressure. The effect of excess pressure can be reduced by inserting a relief valve in the assembly.

Temperature: Ambient temperature : It is difficult to protect a pressure gauge from an ambient temperature that is either too high or too low. One solution is to move the pressure gauge away from the source of heat or cold. For high precision pressure gauges, Class 0.6 where it will be necessary to make a reading correction as soon as the ambient temperature is different from the reference temperature (at which the pressure gauges are graduated) ie 20 °C +/- 2 °C (unless otherwise specified).

Fluid temperature : The pressure gauge will be protected from excessive fluid temperature (on which could cause gas condensation in the sensor) by inserting a siphon or a coolant provided for this purpose. The fluid inside the sensor should not crystallize or freeze there. For extreme service conditions it is recommended to mount the pressure gauge on a separator which will isolate it from the fluid. The filling liquid and the materials should be chosen with care.

Certificat of non contamination: Certain applications require the absence of a given contaminant for parts in contact with the fluid (for example, without traces of oil for oxygen pressure gauges). In this case it is the responsibility of the installer to ensure that the equipment is properly certified for the process requirements before installing it.

Commissioning: As with any installation, pressurization must be carried out gently to avoid excessive pressure or sudden temperature variations. For this reason it is advisable to gradually open the shut-off valves.

Maintenance: The safety of the installation also depends on the good condition of the pressure gauges. The indications of the pressure gauge(s) must be reliable. In the event of a reading leaving a doubt about the quality of the measurement, the pressure gauge must be replaced or checked and if necessary recalibrated. Calibration tests should be performed regularly. These tests must be carried out by qualified personnel. The separators must be removed regularly (every six months) from the line (the pressure gauge must not be separated) to clean the membrane (process side). Use a suitable solvent, avoiding any solid object which could damage the membrane.



DÉTECTEUR DE NIVEAU
LEVEL SWITCHES

TP6000/TP6001

Transmetteur de pression
Pressure transmitter



Capteur céramique
Corps : Inox 1.4301
Alimentation : 8-32 VDC
Sortie 4-20mA 2 fils
Température du fluide : -25°C / +125°C
Protection IP65
Classe 0.5

Ceramic sensor
Body: Stainless steel 1.4301
Voltage: 8-32 VDC
Output 4-20mA 2 wires
Fluid temperature: -25°C / +125°C
IP65 protection
Class 0.5

DN		Kg	Ref.
mm	inch		
8	1/4"	0,12	TP6000-0/10b
8	1/4"	0,12	TP6000-0/6b
15	1/2"	0,12	TP6001-0/10b
15	1/2"	0,12	TP6001-0/6b

P7101

Pressostat à différentiel réglable
Pressure switches



Boîtier : Métal
Raccordement : 1/4"G femelle
Courant d'utilisation : 220V-250V-380V
Protection IP40

Case: Metal
Connection: 1/4"G female
Voltage: 220V-250V-380V
IP40 protection

Echelle (b) Range (b)	L	Kg	Ref.
0,2 à 8	95	0,47	P7101-01
5 à 16	95	0,47	P7101-02
8 à 28	95	0,46	P7101-03



Pour la protection de pompe (ballon d'eau)
For pump protection

SN6000

Sonde de niveau immergeable
Immersible pressure transmitter



Matière : Inox 316L
Joint : FKM
Protection : IP68
Sortie 4-20mA
Température de service : -10°C / +70°C

Construction: Stainless steel 316L
Gasket: FKM
Protection: IP68
Output 4-20mA
Working temperature: -10°C / +70°C

Cable	L	Kg	Ref.
10 m	115	0,2	SN6000-0.6B
20 m	115	0,2	SN6000-1B



ACCESSOIRE
ACCESSORIE

CN9500

Contacteur à flotteur
Level switch



Corps : Polypropylène
Raccordement : 3 fils 230V
Température max : +50°C
Livré avec un contrepoids

Body: Polypropylene
Connection: 3 wires 230V
Max Temperature: +50°C
Counterweight included

L Cable	Ref.
5 m	CN9500-0005
10 m	CN9500-0010
20 m	CN9500-0020



Permet une bonne gestion du niveau
Allows good level management



Utilisation en eaux claires et chargées
Use in clear and charged water



**COMPTEURS
FLOW METERS**

CE1140EF

Compteur d'eau jet unique
Single jet water meter



Corps : Laiton
Chapeau : Plastique
Cadrant : Sec
Raccordement : Mâle BSP
Pression, maxi. : 16 bar
Pour eau froide : 30°C
Montage : Vertical ou horizontal

Body: Brass
Bonnet: Plastic
Dial: Dry
Connection: Male BSP
Max Pressure: 16 bar
For cold water: 30°C
Mounting: Vertical or horizontal

ACS

DN inch	Débit flow M3/H	Calibre Bore	L	Kg	Ref.
3/4"	1,5	15	110	0,5	CE1140EF-0015
1"	2,5	20	130	0,6	CE1140EF-0020

EN OPTION | OPTION

**Dispositif émetteur d'impulsion
Pulse emitting device**

CE1150EF

Compteur d'eau jet multiple cadran sec
Dry dial multi jet water meter



Corps : Laiton
Chapeau : Laiton
Raccordement : Mâle BSP
Pression max : 16 bar
Pour eau froide : 30°C
Montage : Horizontal

Body: Brass
Bonnet: Brass
Connection: Male BSP
Max Pressure: 16 bar
For cold water: 30°C
Mounting: Horizontal

ACS

DN inch	Débit/flow M3/H	Calibre Bore	L	Kg	Ref.
3/4"	1,5	15	170	1,4	CE1150EF-0015
1"	2,5	20	190	1,6	CE1150EF-0020
1"1/4	3	25	260	2,2	CE1150EF-0025
1"1/2	5	30	260	2,3	CE1150EF-0032
2"	10	40	300	4,2	CE1150EF-0040
2"1/2	15	50	300	4,4	CE1150EF-0050

EN OPTION | OPTION

**Dispositif émetteur d'impulsion
Pulse emitting device**

CE1141EF

Compteur d'eau jet unique
Single jet water meter



Corps : Laiton
Chapeau : Plastique
Cadrant : Sec
Raccordement : Femelle BSP
Pression max : 16 bar
Pour eau froide : 40°C
Montage : Vertical ou horizontal

Body: Brass
Bonnet: Plastic
Dial: Dry
Connection: Female BSP
Max pressure: 16 bar
For cold water: 40°C
Mounting: Vertical or horizontal

DN		L	Kg	Ref.
mm	inch			
15	1/2"	110	0,65	CE1141EF-0015
20	3/4"	130	0,85	CE1141EF-0020

CE11RACC

Raccord de compteur laiton mâle - femelle BSP
Male - female BSP meter fitting



Prix unitaire / Unit price

DN Racc. Femelle DN Female nut		Ø racc. Mâle Ø male nipple	Ref.
mm	inch		
15	1/2"	3/8"	CE11RACC-015010
20	3/4"	1/2"	CE11RACC-020015
20	3/4"	3/4"	CE11RACC-020020
25	1"	3/4"	CE11RACC-025020
32	1"1/4	1"	CE11RACC-032025
40	1"1/2	1"1/4	CE11RACC-040032
50	2"	1"1/2	CE11RACC-050040
60	2"1/2	2"	CE11RACC-065050





Compteur Woltmann | Woltmann type water meter

- ✓ Très grande précision
- ✓ Faible perte de charge
- ✓ Maintenance facile
- ✓ Very high precision
- ✓ Low pressure drop
- ✓ Easy maintenance

CE4242

PN16

Compteur d'eau à brides PN16 type Woltmann - Cadran sec
Woltmann type flanged water meter PN16



ACS



**Peinture époxy 170 microns
Epoxy coated 170 microns**



Corps : Fonte ductile GGG40
Chapeau : Plastique
Raccordement : Brides PN16 (DN>150 PN10/16)
Pression max : 16 bar
Pour eau froide : 40°C
Voir passeport technique pour les débits max/mini

Body: Ductile iron GGG40
Bonnet: Plastic
Connection: Flanged PN16 (DN>150 PN10/16)
Max pressure: 16 bar
For cold water: 40°C
See on the technical sheet the max/min flow

EN OPTION | OPTION

**Dispositif émetteur d'impulsion
Pulse emitting device**

DN		L	Kg	Débit Flow (m3/h)	Ref.
mm	inch				
50	2"	200	1,1	40	CE4242-0050
65	2"1/2	200	1,3	63	CE4242-0065
80	3"	225	1,4	63	CE4242-0080
100	4"	250	1,9	100	CE4242-0100
125	5"	250	2,2	160	CE4242-0125
150	6"	300	4,4	250	CE4242-0150
200	8"	350	5,3	400	CE4242-0200
250	10"	450	10,3	630	CE4242-0250
300	12"	500	11,5	1000	CE4242-0300
400	16"	600	23,0	1600	CE4242-0400
500	20"	800	32,0	2500	CE4242-0500

CE4252

PN25

Compteur d'eau à brides PN25 type Woltmann - Cadran sec
Woltmann type flanged water meter PN25



ACS



Corps : Fonte ductile GGG40
Chapeau : Plastique
Raccordement : Brides PN25
Pression max : 25 bar
Pour eau froide : 40°C
Voir passeport technique pour les débits max/mini

Body: Ductile iron GGG40
Bonnet: Plastic
Connection: Flanged PN25
Max pressure: 25 bar
For cold water: 40°C
See on the technical sheet the max/min flow

EN OPTION | OPTION

**Dispositif émetteur d'impulsion
Pulse emitting device**

*sur demande / on request

DN		L	Kg	Débit Flow (m3/h)	Ref.
mm	inch				
50	2"	200	*	40	CE4252-0050
65	2"1/2	200	*	63	CE4252-0065
80	3"	225	*	63	CE4252-0080
100	4"	250	*	100	CE4252-0100
125	5"	250	*	160	CE4252-0125
150	6"	300	*	250	CE4252-0150
200	8"	350	*	400	CE4252-0200
250	10"	450	*	630	CE4252-0250
300	12"	500	*	1000	CE4252-0300
400	16"	600	*	1600	CE4252-0400
500	20"	800	*	2500	CE4252-0500

CE4262

PN40

Compteur d'eau à brides PN40 type Woltmann - Cadran sec
Woltmann type flanged water meter PN40



ACS



Corps : Fonte ductile GGG40
Chapeau : Plastique
Raccordement : Brides PN40
Pression max : 40 bar
Pour eau froide : 40°C
Voir passeport technique pour les débits max/mini

Body: Ductile iron GGG40
Bonnet: Plastic
Connection: Flanged PN40
Max pressure: 40 bar
For cold water: 40°C
See on the technical sheet the max/min flow

EN OPTION | OPTION

**Dispositif émetteur d'impulsion
Pulse emitting device**

*sur demande / on request

DN		L	Kg	Débit Flow (m3/h)	Ref.
mm	inch				
50	2"	200	*	40	CE4262-0050
65	2"1/2	200	*	63	CE4262-0065
80	3"	225	*	63	CE4262-0080
100	4"	250	*	100	CE4262-0100
125	5"	250	*	160	CE4262-0125
150	6"	300	*	250	CE4262-0150
200	8"	350	*	400	CE4262-0200
250	10"	450	*	630	CE4262-0250
300	12"	500	*	1000	CE4262-0300
400	16"	600	*	1600	CE4262-0400
500	20"	800	*	2500	CE4262-0500



DÉBITMÈTRE ÉLECTROMAGNÉTIQUE ELECTROMAGNETIC FLOW METER

MUT2200EL

Débitmètre électromagnétique
Electromagnetic flow meter



Corps : Acier carbone (cartouche dure qui protège le corps)
Raccordement : Brides PN10/16/25/40
Revêtement intérieur : Ebonite (sauf DN<125 en PTFE)
Température de service : 0°/+70°C
4 électrodes de mesure hastelloy
Convertisseur compact MC608 avec écran LED
Alimentation : 90-265 VAC
Sortie 4-20mA + 485 MODBUS
Interface IRCOM
IP68

Body: Steel (hard cartridge that protects the body)
Connection: Flanged PN10/16/25/40
Internal liner: Ebonite (except DN<125 in PTFE)
Working temperature: 0°/+70°C
4 electrodes in hastelloy
Compact MC608 converter with LED screen
Power: 90-265 VAC
4-20mA + 485 MODBUS output
IRCOM interface
IP68



Boîtier aluminium IP68
Aluminium case IP68



Affiche le débit dans le tuyau en simultané
Displays the flow in the pipe simultaneously

DN			PN10	PN16	PN25	PN40
mm	inch	L	Ref.	Ref.	Ref.	Ref.
15	1/2"	200	MUT2200ELPN10-0015	MUT2200ELPN16-0015	MUT2200ELPN25-0015	MUT2200ELPN40-0015
20	3/4"	200	MUT2200ELPN10-0020	MUT2200ELPN16-0020	MUT2200ELPN25-0020	MUT2200ELPN40-0020
25	1"	200	MUT2200ELPN10-0025	MUT2200ELPN16-0025	MUT2200ELPN25-0025	MUT2200ELPN40-0025
32	1 1/4"	200	MUT2200ELPN10-0032	MUT2200ELPN16-0032	MUT2200ELPN25-0032	MUT2200ELPN40-0032
40	1 1/2"	200	MUT2200ELPN10-0040	MUT2200ELPN16-0040	MUT2200ELPN25-0040	MUT2200ELPN40-0040
50	2"	200	MUT2200ELPN10-0050	MUT2200ELPN16-0050	MUT2200ELPN25-0050	MUT2200ELPN40-0050
65	2 1/2"	200	MUT2200ELPN10-0065	MUT2200ELPN16-0065	MUT2200ELPN25-0065	MUT2200ELPN40-0065
80	3"	200	MUT2200ELPN10-0080	MUT2200ELPN16-0080	MUT2200ELPN25-0080	MUT2200ELPN40-0080
100	4"	250	MUT2200ELPN10-0100	MUT2200ELPN16-0100	MUT2200ELPN25-0100	MUT2200ELPN40-0100
125	5"	250	MUT2200ELPN10-0125	MUT2200ELPN16-0125	MUT2200ELPN25-0125	MUT2200ELPN40-0125
150	6"	300	MUT2200ELPN10-0150	MUT2200ELPN16-0150	MUT2200ELPN25-0150	MUT2200ELPN40-0150
200	8"	350	MUT2200ELPN10-0200	MUT2200ELPN16-0200	MUT2200ELPN25-0200	MUT2200ELPN40-0200
250	10"	450	MUT2200ELPN10-0250	MUT2200ELPN16-0250	MUT2200ELPN25-0250	MUT2200ELPN40-0250
300	12"	500	MUT2200ELPN10-0300	MUT2200ELPN16-0300	MUT2200ELPN25-0300	MUT2200ELPN40-0300
350	14"	550	MUT2200ELPN10-0350	MUT2200ELPN16-0350	MUT2200ELPN25-0350	MUT2200ELPN40-0350
400	16"	600	MUT2200ELPN10-0400	MUT2200ELPN16-0400	MUT2200ELPN25-0400	MUT2200ELPN40-0400
450	18"	450	MUT2200ELPN10-0450	MUT2200ELPN16-0450	MUT2500ELPN25-0450	MUT2200ELPN40-0450
500	20"	500	MUT2200ELPN10-0500	MUT2200ELPN16-0500	MUT2500ELPN25-0500	MUT2200ELPN40-0500
600	24"	600	MUT2200ELPN10-0600	MUT2200ELPN16-0600	MUT2500ELPN25-0600	MUT2200ELPN40-0600
700	28"	700	MUT2200ELPN10-0700	MUT2200ELPN16-0700	MUT2500ELPN25-0700	MUT2200ELPN40-0700
800	32"	800	MUT2200ELPN10-0800	MUT2200ELPN16-0800	MUT2500ELPN25-0800	MUT2200ELPN40-0800
900	36"	900	MUT2200ELPN10-0900	MUT2200ELPN16-0900	MUT2500ELPN25-0900	MUT2200ELPN40-0900
1000	40"	1000	MUT2200ELPN10-1000	MUT2200ELPN16-1000	MUT2500ELPN25-1000	MUT2200ELPN40-1000
1200	48"	1200	MUT2200ELPN10-1200	MUT2200ELPN16-1200	MUT2500ELPN25-1200	MUT2200ELPN40-1200
1400	56"	1400	MUT2200ELPN10-1400	MUT2200ELPN16-1400	MUT2500ELPN25-1400	MUT2200ELPN40-1400
1600	64"	1600	MUT2500ELPN10-1600	MUT2200ELPN16-1600	MUT2500ELPN25-1600	MUT2200ELPN40-1600
1800	72"	1800	MUT2200ELPN10-1800	MUT2200ELPN16-1800	MUT2500ELPN25-1800	MUT2200ELPN40-1800
2000	80"	2000	MUT2200ELPN10-2000	MUT2200ELPN16-2000	MUT2500ELPN25-2000	MUT2200ELPN40-2000



PRODUITS ASSOCIÉS | RELATED PRODUCTS

MUT2200KITDEPORT

Kit de déportation pour débitmètre MUT2200EL
 Deportation kit for flow meter MUT2200EL



Comprenant : bouchon de protection sur manchette et sur convertisseur + équerre de fixation Inox (pour fixation murale du convertisseur).
Option à rajouter sur le prix du modèle MUT2200EL
 + rajouter MUT2200CABLE (longueur souhaitée voir ci-dessous).

Includes: protection plug on the sleeve and the converter + Stainless steel mounting bracket (to wall mount the converter).
Option to add to the price of model MUT2200EL + add
 MUT2200CABLE (with desired length).

Ref.
MUT2200KITDEPORT



Permet de déporter le convertisseur électronique type MC 608 jusqu'à 100 mètres
To separate the electronic MC 608 type converter up to 100 meters

MUT2200CABLE

Kit de câble pour débitmètre MUT2200
 Cable kit for flow meter MUT2200



Comprenant : 1 Câble gris pour connection bobine + 1 câble noir pour connection électrodes
 Longueur mini 5m / Maxi 100m
 Ensemble pré-cablé en usine et testé sur banc d'essai MID.

Includes: 1 grey cable for connection coil + 1 black cable for connection electrodes. Min. length 5m/ Max. length 100m
Ensemble pre-cabled in factory and tested on MID test bench.

Ref.
MUT2200CABLE

Mètre linéaire de câble par multiple de 5 ne pouvant pas dépasser 100 mètres.

Linear meter cable length in multiples of 5, not exceeding 100 meters.

MUT1222

Débitmètre électromagnétique à insertion
 Electromagnetic insertion flowmeter



Corps : Inox 304
Pression : 20 bar max
Composé de :
 - 2 électrodes inox 316L
 - 1 vanne à sphère inox 1"
Unité de la tête : 22mm
Sonde : 12mm
 Prise de connection pour manomètre
 Poignée avec direction du flux
 Température max de service : 80°C
 Convertisseur compact MC608A avec écran LED - Alimentation 90-265 VAC. Boitier aluminium IP68
 Sortie 4-20mA + RS485 sortie MODBUS Interface IRCOM

Body: Stainless steel 304
Pressure: 20 bar max
Composed of:
 - 2 Stainless steel 316L electrodes
 - 1 Stainless steel ball valve 1"
Head of the unit: 22mm
Probe: 12mm
 Input connection for pressure gauge
 Handle grips with flow direction
 Max temperature of service: 80°C
 Compact MC608A with LED screen
 Voltage 90-265 VAC. Aluminium case IP68
 4-20mA output + RS485 MODBUS output IRCOM interface

Tube	Ref.
50-600	MUT1222S
200-1500	MUT1222M
450-2000	MUT1222L

Voir passeport technique pour les débits

See on the technical sheet the flow



L'ensemble de notre gamme de débitmètres est testée sur un banc d'essai dynamique agréé MID. Chaque débitmètre est fourni avec certificat d'essais.
Our flowmeter range is tested on an MID-approved test bench. Each flowmeter is supplied with a test certificate.



STABILISATEUR D'ÉCOULEMENT SUSTAINING FLOW VALVE

STABPN1016 | STABPN10 | STABPN16 | STABPN25

Stabilisateur d'écoulement
Sustaining flow valve

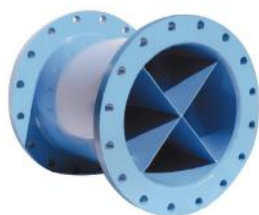

**Pour stabiliser le débit
To stabilize the flow**



Corps : Acier mécano-soudé Epoxy
Raccordement : A brides

Body: Epoxy-coated welded steel
Connection: Flanged

DN		PN10	PN16	PN25
mm	inch	Ref.	Ref.	Ref.
50	2"	voir / see PN16	STABPN1016-0050	STABPN25-0050
65	2"1/2		STABPN1016-0065	STABPN25-0065
80	3"		STABPN1016-0080	STABPN25-0080
100	4"		STABPN1016-0100	STABPN25-0100
125	5"		STABPN1016-0125	STABPN25-0125
150	6"		STABPN1016-0150	STABPN25-0150
200	8"	STABPN10-0200	STABPN16-0200	STABPN25-0200
250	10"	STABPN10-0250	STABPN16-0250	STABPN25-0250
300	12"	STABPN10-0300	STABPN16-0300	STABPN25-0300
350	14"	STABPN10-0350	STABPN16-0350	STABPN25-0350
400	16"	STABPN10-0400	STABPN16-0400	STABPN25-0400
500	20"	STABPN10-0500	STABPN16-0500	STABPN25-0500
600	24"	STABPN10-0600	STABPN16-0600	STABPN25-0600
700	28"	STABPN10-0700	STABPN16-0700	STABPN25-0700
800	32"	STABPN10-0800	STABPN16-0800	STABPN25-0800
900	36"	STABPN10-0900	STABPN16-0900	STABPN25-0900
1000	40"	STABPN10-1000	STABPN16-1000	STABPN25-1000





CONTRÔLEURS DE CIRCULATION
SIGHT GLASSES

CD2140

Contrôleur de circulation à bille
Sight glass with ball



Corps :
- Laiton (1/2" - 1")
- Bronze (1"1/4 - 2")
Glace : Double glace en verre trempé
Raccordement : Femelle BSP
Température de service : +5°C/+80°C
Pression max : 16 bar

Body:
- Brass (1/2" - 1")
- Bronze (1"1/4 - 2")
Glass: Hardened double glass window
Connection: Female BSP
Working temperature: +5°C/+80°C
Max Pressure: 16 bar

DN		L	Ref.
mm	inch		
15	1/2"	95	CD2140-0015
20	3/4"	100	CD2140-0020
25	1"	107	CD2140-0025
32	1"1/4	126	CD2140-0032
40	1"1/2	137	CD2140-0040
50	2"	170	CD2140-0050

CD3140

Contrôleur de circulation femelle BSP
BSP female threaded Sight flow indicator



Corps : Fonte EN-GJL -200
Glace : Double glace en verre trempé
Raccordement : Femelle BSP
Température de service : -10°C/+180°C
Pression max : 16 bar

Body: Cast iron EN-GJL -200
Glass: Hardened double glass window
Connection: Female BSP
Working temperature: -10°C/+180°C
Max Pressure: 16 bar

DN		L	Kg	Ref.
mm	inch			
15	1/2"	75	0,70	CD3140-0015
20	3/4"	90	1,00	CD3140-0020
25	1"	90	1,20	CD3140-0025
32	1"1/4	120	2,10	CD3140-0032
40	1"1/2	120	2,10	CD3140-0040
50	2"	140	3,30	CD3140-0050

CD3241

Contrôleur de circulation à brides
Flanged sight flow indicator



Corps : Fonte EN-GJL -250
Glace : Double glace en verre trempé
Raccordement : A brides ISO PN 10/16
Température de service : +5°C/+180°C
Pression max : 16 bar

Body: Cast iron EN-GJL -250
Glass: Hardened double glass window
Connection: PN 10/16 flanged
Working temperature: +5°C/+180°C
Max Pressure: 16 bar

Autres diamètres sur demande / Other diameters on request

DN		L	Kg	Ref.
mm	inch			
15	1/2"	130	2,90	CD3241-0015
20	3/4"	150	3,50	CD3241-0020
25	1"	160	4,00	CD3441-0025
32	1"1/4	180	6,00	CD3241-0032
40	1"1/2	200	6,50	CD3241-0040
50	2"	230	9,00	CD3241-0050
65	2"1/2	290	15,00	CD3241-0065
80	3"	310	17,70	CD3241-0080
100	4"	350	24,90	CD3241-0100

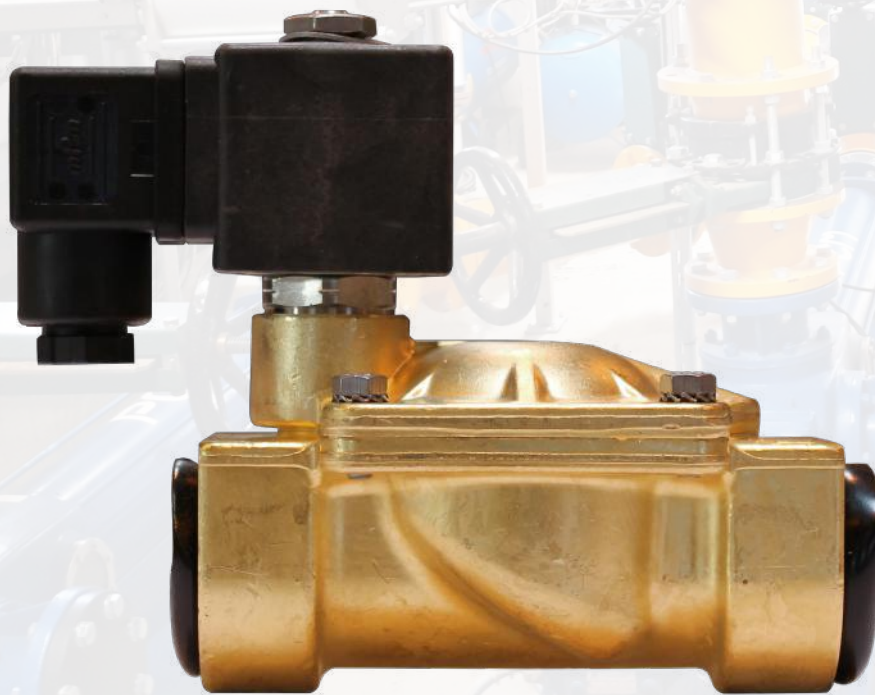

ÉLECTROVANNE SOLENOID VALVE

ÉLECTROVANNES 2/2
2/2 SOLENOID VALVES

310 > 312

ÉLECTROVANNES 3/2
3/2 SOLENOID VALVES

313

ÉLECTROVANNE

SOLENOID VALVE



ÉLECTROVANNES POUR FLUIDES

Une électrovanne est un appareil de robinetterie qui ouvre ou ferme un circuit par l'envoi d'un courant électrique. Elle actionne un champ électromagnétique créé par la bobine montée sur l'électrovanne.

SOLENOID VALVES

Solenoid valves open or close a circuit via sending an electrical current that acts on an electromagnetic field created by the coil mounted on the solenoid valve.



ÉLECTROVANNES TYPE 2/2 - 2 VOIES - 2 POSITIONS

2/2 - 2 WAY - 2 POSITIONS PILOT SOLENOID VALVES

EV1140

Normalement Fermée | Normally Closed

Electrovanne Normalement Fermée femelle BSP

Female BSP solenoid valve Normally Closed



Corps : Laiton
 Etanchéité : NBR
 Raccordement : Femelle BSP
 Pression max : DN ≤ 1" 20 bar
 DN > 1" 10 bar
 Température max de service : +90°C
 Pression différentielle mini :
 DN ≤ 2" 0,1 bar
 DN > 2" 0,5 bar
 Tension :
 Voir ref EVBOBINE pour les tensions standards (autres, nous consulter)

Autres membranes sur demande (EPDM, FPM ...)

Body: Brass
 Seal: NBR
 Connection: Female BSP
 Pressure max: DN ≤ 1" 20 bar
 DN > 1" 10 bar
 Max Temperature: +90°C
 Min. differential pressure:
 DN ≤ 2" 0,1 bar
 DN > 2" 0,5 bar
 Voltage:
 See ref EVBOBINE for standard voltages (others, on request)

Other membrane materials on request (EPDM, FPM ...)

DN		L	Kg	Ref.
mm	inch			
10	3/8"	69	0,5	EV1140-0010
15	1/2"	72	0,5	EV1140-0015
20	3/4"	100	0,8	EV1140-0020
25	1"	104	1,1	EV1140-0025
32	1"1/4	145	2,5	EV1140-0032
40	1"1/2	145	3	EV1140-0040
50	2"	173	4,6	EV1140-0050
65	2"1/2	245	9,4	EV1140-0065
80	3"	250	11,2	EV1140-0080



EV1141

Normalement Ouverte | Normally Opened

Electrovanne Normalement Ouverte femelle BSP

Female BSP solenoid valve **Normally Opened**

Corps : Laiton
 Etanchéité : NBR
 Raccordement : Femelle BSP
 Pression max :
 DN ≤ 1" 20 bar
 DN > 1" 10 bar
 Température max de service : +90°C
 Pression différentielle min : DN ≤ 2" 0,1 bar
 DN > 2" 0,5 bar
 Tension :
 voir ref EVBOBINE ci-dessous pour les tensions standards (autres, nous consulter)

Autres membranes sur demande
 (EPDM, FPM ...)

Body: Brass
 Seal: NBR
 Connection: female BSP
 Pressure max:
 DN ≤ 1" 20 bar
 DN > 1" 10 bar
 Max Temperature: +90°C
 Min differential pressure: DN ≤ 2" 0,1 bar
 DN > 2" 0,5 bar
 Voltage:
 See ref EVBOBINE below for standard voltages (others, consult us)

Other membrane materials on request
 (EPDM, FPM ...)

DN		L	Kg	Ref.
mm	inch			
15	1/2"	72	0,5	EV1141-0015
20	3/4"	100	0,8	EV1141-0020
25	1"	104	1,1	EV1141-0025
32	1"1/4	145	2,5	EV1141-0032
40	1"1/2	145	3	EV1141-0040
50	2"	173	4,6	EV1141-0050

PRODUIT ASSOCIÉ | RELATED PRODUCT

EVBOBINE

Bobine + Connecteur pour électrovanne EV1140 / EV1141

Coil + Connector for solenoid valve EV1140 / EV1141



Kg	Ref.
0,16	EVBOBINE-024AC
	EVBOBINE-024CC
	EVBOBINE-048AC
	EVBOBINE-230AC

EV1110

Membrane attelée | Servo-assisted

Electrovanne Normalement Fermée femelle BSP - à membrane attelée

Female BSP **servo-assisted** solenoid valve **Normally Closed**

Corps : Laiton
 Etanchéité : NBR
 Raccordement : Femelle BSP
 Pression max : 10 bar
 Température max de service : +80°C
 Pression différentielle min : 0 bar
 Tension :
 Alternatif 12-24-48-110-230 Volts
 Continu 12-24-48-110 Volts

Autres membranes sur demande
 (EPDM, FPM ...)
 Toujours livré avec bobine (spécifier la tension souhaitée lors de la commande).

Body: Brass
 Seal: NBR
 Connection: female BSP
 Pressure max: 10 bar
 Max Temperature: +80°C
 Min differential pressure: 0 bar
 Voltage:
 Alternatif current 12-24-48-110-230 Volts
 Direct current 12-24-48-110 Volts

Other membrane materials on request
 (EPDM, FPM ...)
 Delivered with coil (specify desired voltage when ordering).

DN		L	Kg	Ref.
mm	inch			
10	3/8"	61	0,68	EV1110-0010
15	1/2"	61	0,66	EV1110-0015
20	3/4"	100	1,10	EV1110-0020
25	1"	100	1,20	EV1110-0025
32	1"1/4	146	5,20	EV1110-0032
40	1"1/2	146	5,00	EV1110-0040
50	2"	174	6,50	EV1110-0050



Ne nécessite pas de DELTA P car membrane attelée
Does not require DELTA P because it is servo-assisted

EV1144

Membrane attelée ACS | ACS Servo-assisted

Electrovanne Normalement Fermée femelle BSP - ACS

Female BSP servo-assisted solenoid valve Normally Closed - ACS



Corps : Laiton CW617N
 Etanchéité : EPDM
 Raccordement : Femelle BSP
 Pression de service max : 10 bar
 Température max de service : +90°C
 Tension :
 Alternatif 24/230 Volts
 Continu 24 Volts

Body: Brass CW617N
 Seal: EPDM
 Connection: Female BSP
 Max working pressure: 10 bar
 Max working temperature: +90°C
 Voltage:
 Alternatif current 24/230 Volts
 Direct current 24 Volts

DN		L	Kg	Ref.
mm	inch			
15	1/2"	61	0,66	EV1144-0015
20	3/4"	100	1,10	EV1144-0020
25	1"	100	1,20	EV1144-0025

ACS

Toujours livré avec bobine (spécifier la tension souhaitée lors de la commande).

Delivered with coil (specify desired voltage when ordering).



Ne nécessite pas de DELTA P car membrane attelée
Does not require DELTA P because it is servo-assisted

EV6100

Inox | Stainless steel

Electrovanne inox Normalement Fermée - femelle BSP

Stainless steel female BSP solenoid valve Normally Closed



Corps : Inox 316
 Etanchéité : FPM
 Raccordement : Femelle BSP
 Pression max : 10 bar
 Température de service : -10°C/+90°C
 Pression différentielle min : 0,5 bar
 Tension :
 Alternatif 24-230 Volts
 Continu 24 Volts

Body: Stainless steel 316
 Seal: FPM
 Connection: female BSP
 Pressure max: 10 bar
 Working temperature: -10°C/+90°C
 Min differential pressure: 0.5 bar
 Voltage:
 Alternatif current 24-230 Volts
 Direct current 24 Volts

DN		L	Kg	Ref.
mm	inch			
10	3/8"	66,5	0,74	EV6100-0010
15	1/2"	66,5	0,73	EV6100-0015
20	3/4"	96	1,43	EV6100-0020
25	1"	96	1,43	EV6100-0025
32	1*1/4	131	2,56	EV6100-0032
40	1*1/2	131	2,32	EV6100-0040
50	2"	160	3,44	EV6100-0050

Autres qualités de membrane sur demande.
 Toujours livré avec bobine (spécifier la tension souhaitée lors de la commande).

Other membrane materials on request.
 Delivered with coil (specify desired voltage when ordering).

EV1142

Fioul | Fuel oil

Electrovanne Normalement Fermée femelle BSP pour usage "fioul"

Female BSP solenoid valve Normally Close for "fuel oil" use



Corps : Laiton
 Etanchéité : FPM
 Raccordement : Femelle BSP
 Pression max : 15 bar
 Température max de service : +60°C
 Pression différentielle min : 0,3 bar
 Tension :
 Alternatif 12-24-48-110-230-400 Volts
 Continu 12-24-48-110 Volts

Body: Brass
 Seal: FPM
 Connection: female BSP
 Pressure max: 15 bar
 Max Temperature: +60°C
 Min differential pressure: 0.3 bar
 Voltage :
 Alternatif current 12-24-48-110-230-400 Volts
 Direct current 12-24-48-110 Volts

DN		L	Kg	Ref.
mm	inch			
8	1/4"	42	0,40	EV1142-0008
10	3/8"	47	0,45	EV1142-0010
15	1/2"	56	0,50	EV1142-0015

Toujours livré avec bobine (spécifier la tension souhaitée lors de la commande).

Delivered with coil (specify desired voltage when ordering).





ÉLECTROVANNES TYPE 3/2 - 3 VOIES - 2 POSITIONS 3/2 - 3 WAY - 2 POSITIONS PILOT SOLENOID VALVES



Electrovanne de pilotage pour AIR MOTEUR. Montage sur vanne à commande pneumatique.
Solenoid pilot valve for AIR MOTOR. Mounting on pneumatic operated valves.

EDM2

NEW

Electrovanne 3/2 Normalement Fermée 1/8"

Solenoid valve 3/2 Normally Closed 1/8"



Corps : Aluminium anodisé
Raccordement : BSP Mâle /Femelle
IP65
Pression de service : 10 bar
Température de service : +50°C

Toujours livré avec bobine (spécifier la tension souhaitée lors de la commande).

Body: Anodised Aluminium
Connection: M/F BSP
IP65
Working pressure: 10 bar
Working temperature: +50°C

Delivered with coil (specify desired voltage when ordering).

Ref.

MH-230VAC

MH-24VAC

MH-24VCC

EDEBB62

Electrovanne 3/2 Normalement Fermée 1/4"

Solenoid valve 3/2 Normally Closed 1/4"



Corps : Laiton CW617N
Etanchéité : FPM
Raccordement : Femelle BSP 1/4
Température de service : +140°C
Pression de service : 10 bar

Normalement Ouvert, nous consulter.

Toujours livré avec bobine (spécifier la tension souhaitée lors de la commande).

Body: Brass CW617N
Seal: FPM
Connection: female BSP 1/4
Working temperature: +140°C
Working pressure: 10 bar

Normally Opened, on request.

Delivered with coil (specify desired voltage when ordering).

Ref.

EDEBB62-24VAC

EDEBB62-48VAC

EDEBB62-110VAC

EDEBB62-230VAC

EDEBB62-12VCC

EDEBB62-24VCC

EDEBB62-48VCC

EDEBB62-110VCC



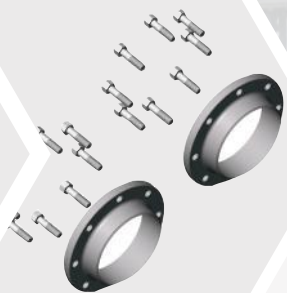

RACCORD | BRIDE | JOINT COUPLING | FLANGE | GASKET

RACCORDS INOX
STAINLESS STEEL
COUPLINGS 316 > 317

RACCORDS ALUMINIUM
ALUMINIUM
COUPLINGS 318 > 319

BRIDES ET JOINTS
FLANGES & GASKETS
320 > 323



RACCORDS SYMÉTRIQUES INOX
STAINLESS STEEL SYMETRICAL COUPLINGS

RACC6503

Raccord symétrique à douille annelée réduite à verrou avec collerette
 Reduce hose coupling with lock and collar



Corps : Inox CF8M
 Joint : FKM
 Temperature de service :
 -10°C/+180°C
 Pression de service : 16 bar

Body: Stainless steel CF8M
 Gasket: FKM
 Working temperature: -10°C/+180°C
 Working pressure: 16 bar

DN		L	Kg	Ref.
mm	inch			
40	1 1/2"	93	0,49	RACC6503-0040
50	2"	123,5	0,96	RACC6503-0050
65	2 1/2"	126	1,21	RACC6503-0065
80	3"	145	1,9	RACC6503-0080
100	4"	162	3,11	RACC6503-0100

RACC6144

Raccord symétrique femelle BSP sans verrou
 Female BSP coupling without lock



Corps : Inox CF8M
 Joint : FKM
 Temperature de service :
 -10°C/+180°C
 Pression de service : 16 bar

Body: Stainless steel CF8M
 Gasket: FKM
 Working temperature: -10°C/+180°C
 Working pressure: 16 bar

DN		L	Kg	Ref.
mm	inch			
15	1/2"	30	0,07	RACC6144-0015
20	3/4"	33	0,07	RACC6144-0020
25	1"	34	0,09	RACC6144-0025
32	1 1/4"	48	0,24	RACC6144-0032
40	1 1/2"	42	0,19	RACC6144-0040
50	2"	49	0,37	RACC6144-0050
65	2 1/2"	53	0,48	RACC6144-0065
80	3"	59	0,93	RACC6144-0080
100	4"	63	0,89	RACC6144-0100

RACC6142

Raccord symétrique male BSP sans verrou
 Male BSP coupling without lock



Corps : Inox CF8M
 Joint : FKM
 Temperature de service :
 -10°C/+180°C
 Pression de service : 16 bar

Body: Stainless steel CF8M
 Gasket: FKM
 Working temperature: -10°C/+180°C
 Working pressure: 16 bar

DN		L	Kg	Ref.
mm	inch			
20	3/4"	37	0,09	RACC6142-0020
25	1"	43	0,15	RACC6142-0025
32	1 1/4"	43,5	0,26	RACC6142-0032
40	1 1/2"	53	0,29	RACC6142-0040
50	2"	65	0,55	RACC6142-0050
65	2 1/2"	65	0,74	RACC6142-0065
80	3"	78	0,93	RACC6142-0080
100	4"	83	1,53	RACC6142-0100

RACC6141

Raccord symétrique femelle BSP à verrou
 Female BSP coupling with lock



Corps : Inox CF8M
 Joint : FKM
 Temperature de service :
 -10°C/+180°C
 Pression de service : 16 bar

Body: Stainless steel CF8M
 Gasket: FKM
 Working temperature: -10°C/+180°C
 Working pressure: 16 bar

DN		L	Kg	Ref.
mm	inch			
20	3/4"	73	0,22	RACC6141-0020
25	1"	73	0,27	RACC6141-0025
32	1 1/4"	73	0,35	RACC6141-0032
40	1 1/2"	86	0,4	RACC6141-0040
50	2"	90	0,77	RACC6141-0050
65	2 1/2"	89	0,89	RACC6141-0065
80	3"	106	1,35	RACC6141-0080
100	4"	132	2,33	RACC6141-0100



RACC6143

Raccord symétrique male BSP à verrou
Male BSP coupling with lock



Corps : Inox CF8M
Joint : FKM
Température de service :
-10°C/+180°C
Pression de service : 16 bar

Body: Stainless steel CF8M
Gasket: FKM
Working temperature: -10°C/+180°C
Working pressure: 16 bar

DN		L	Kg	Ref.
mm	inch			
20	3/4"	52,7	0,15	RACC6143-0020
25	1"	53,3	0,2	RACC6143-0025
32	1 1/4"	67	0,38	RACC6143-0032
40	1 1/2"	69,5	0,32	RACC6143-0040
50	2"	84,5	0,56	RACC6143-0050
65	2 1/2"	86	0,96	RACC6143-0065
80	3"	99	1,86	RACC6143-0080
100	4"	108	2,13	RACC6143-0100

RACC6145

Raccord symétrique à souder à verrou
Welded symetric coupling with lock



Corps : Inox CF8M
Joint : FKM
Température de service :
-10°C/+180°C
Pression de service : 16 bar

Body: Stainless steel CF8M
Gasket: FKM
Working temperature:
-10°C/+180°C
Working pressure: 16 bar

DN		L	Kg	Ref.
mm	inch			
15	1/2"	46,5	0,09	RACC6145-0015
20	3/4"	51,7	0,14	RACC6145-0020
25	1"	47,5	0,18	RACC6145-0025
32	1 1/4"	60,5	0,3	RACC6145-0032
40	1 1/2"	69,5	0,35	RACC6145-0040
50	2"	85	0,67	RACC6145-0050
65	2 1/2"	83	0,84	RACC6145-0065
80	3"	99	1,34	RACC6145-0080
100	4"	108	2,15	RACC6145-0100

RACC6541

Bouchon à verrou
Cap with lock and chain



Corps : Inox CF8M
Joint : FKM
Température de service :
-10°C/+180°C
Pression de service : 16 bar

Body: Stainless steel CF8M
Gasket: FKM
Working temperature: -10°C/+180°C
Working pressure: 16 bar

DN		L	Kg	Ref.
mm	inch			
20	3/4"	20	0,17	RACC6541-0020
25	1"	22	0,21	RACC6541-0025
32	1 1/4"	21	0,23	RACC6541-0032
40	1 1/2"	36	0,36	RACC6541-0040
50	2"	43	0,49	RACC6541-0050
65	2 1/2"	43	0,67	RACC6541-0065
80	3"	39	1,03	RACC6541-0080
100	4"	53	1,79	RACC6541-0100

RACC6543

Bouchon sans verrou
Cap without lock



Corps : Inox CF8M
Joint : FKM
Température de service :
-10°C/+180°C
Pression de service : 16 bar

Body: Stainless steel CF8M
Gasket: FKM
Working temperature: -10°C/+180°C
Working pressure: 16 bar

DN		L	Kg	Ref.
mm	inch			
25	1"	27	0,07	RACC6543-0025
32	1 1/4"	27	0,09	RACC6543-0032
40	1 1/2"	30	0,16	RACC6543-0040
50	2"	35	0,33	RACC6543-0050
65	2 1/2"	32	0,35	RACC6543-0065
80	3"	40,3	0,5	RACC6543-0080
100	4"	40,5	0,8	RACC6543-0100



RACCORDES SYMÉTRIQUES ALUMINIUM ALUMINIUM SYMETRICAL COUPLINGS

RACC8542

Demi raccord avec verrou à douille annelée
Half coupling with locking ring and hose shank



Corps : Aluminium
Joint : NBR
Pression de service : 16 bar

Body: Aluminium
Gasket: NBR
Working pressure: 16 bar

DN		L	Kg	Ref.
mm	inch			
20	3/4"	74,2	0,06	RACC8542-0020
25	1"	75,5	0,07	RACC8542-0025
32	1 1/4"	79	0,09	RACC8542-0032
40	1 1/2"	92	0,22	RACC8542-0040
50	2"	111,5	0,38	RACC8542-0050
65	2 1/2"	116	0,47	RACC8542-0065
80	3"	146	0,8	RACC8542-0080
100	4"	192	0,98	RACC8542-0100
150	6"	240	3,06	RACC8542-0150

RACC8143

Demi raccord avec verrou à douille fileté BSP
Half coupling with locking ring and BSP threaded end



Corps : Aluminium
Joint : NBR
Pression de service : 16 bar

Body: Aluminium
Gasket: NBR
Working pressure: 16 bar

DN		L	Kg	Ref.
mm	inch			
20	3/4"	52,7	0,05	RACC8143-0020
25	1"	56,5	0,07	RACC8143-0025
32	1 1/4"	67	0,11	RACC8143-0032
40	1 1/2"	69,5	0,16	RACC8143-0040
50	2"	84,5	0,3	RACC8143-0050
65	2 1/2"	86	0,34	RACC8143-0065
80	3"	99	0,59	RACC8143-0080
100	4"	108	0,86	RACC8143-0100
150	6"	158	3,19	RACC8143-0150

RACC8141

Demi raccord avec verrou à douille taraudée BSP
Half coupling with locking ring and BSP threaded end



Corps : Aluminium
Joint : NBR
Pression de service : 16 bar

Body: Aluminium
Gasket: NBR
Working pressure: 16 bar

DN		L	Kg	Ref.
mm	inch			
20	3/4"	59	0,05	RACC8141-0020
25	1"	68	0,09	RACC8141-0025
32	1 1/4"	68	0,12	RACC8141-0032
40	1 1/2"	86	0,21	RACC8141-0040
50	2"	106	0,37	RACC8141-0050
65	2 1/2"	109	0,44	RACC8141-0065
80	3"	103	0,76	RACC8141-0080
100	4"	136	1	RACC8141-0100
150	6"	120	2,35	RACC8141-0150



RACC8142

Demi raccord sans verrou à douille fileté BSP
Half coupling without locking ring and BSP threaded end



Corps : Aluminium
Joint : NBR
Pression de service : 16 bar

Body: Aluminium
Gasket: NBR
Working pressure: 16 bar

DN		L	Kg	Ref.
mm	inch			
20	3/4"	40	0,03	RACC8142-0020
25	1"	43	0,05	RACC8142-0025
32	1"1/4	43,5	0,07	RACC8142-0032
40	1"1/2	53	0,12	RACC8142-0040
50	2"	66,5	0,20	RACC8142-0050
65	2"1/2	66,5	0,29	RACC8142-0065
80	3"	78	0,35	RACC8142-0080
100	4"	83	0,52	RACC8142-0100

RACC8144

Demi raccord sans verrou à douille taraudée BSP
Half coupling without locking ring and BSP threaded end



Corps : Aluminium
Joint : NBR
Pression de service : 16 bar

Body: Aluminium
Gasket: NBR
Working pressure: 16 bar

DN		L	Kg	Ref.
mm	inch			
20	3/4"	30	0,03	RACC8144-0020
25	1"	34	0,05	RACC8144-0025
32	1"1/4	48	0,07	RACC8144-0032
40	1"1/2	44,5	0,12	RACC8144-0040
50	2"	48	0,20	RACC8144-0050
65	2"1/2	59,5	0,29	RACC8144-0065
80	3"	59	0,35	RACC8144-0080
100	4"	63	0,52	RACC8144-0100

RACC8541

Bouchon à poignée avec verrou et chaînette
Plug with chain and locking ring



Corps : Aluminium
Joint : NBR
Pression de service : 16 bar

Body: Aluminium
Gasket: NBR
Working pressure: 16 bar

DN		L	Kg	Ref.
mm	inch			
20	3/4"	20	0,06	RACC8541-0020
25	1"	30	0,06	RACC8541-0025
32	1"1/4	21	0,08	RACC8541-0032
40	1"1/2	35	0,12	RACC8541-0040
50	2"	43	0,24	RACC8541-0050
65	2"1/2	43	0,3	RACC8541-0065
80	3"	49	0,48	RACC8541-0080
100	4"	53	0,69	RACC8541-0100
150	6"	85	2,28	RACC8541-0150

BRIDES ET JOINTS
FLANGES & GASKETS
BR5240

Bride à collerette acier forgé PN10/16 - EN 1092-1
 Forged steel welding neck flange PN10/16 - EN 1092-1



Type : Collerette à souder bout à bout

Type: Butt welding neck flange

DN		PN	Ref.
mm	inch		
15	1/2"	PN10/16/25/40	BR5240PN16-0015
20	3/4"	PN10/16/25/40	BR5240PN16-0020
25	1"	PN10/16/25/40	BR5240PN16-0025
32	1"1/4	PN10/16/25/40	BR5240PN16-0032
40	1"1/2	PN10/16/25/40	BR5240PN16-0040
50	2"	PN10/16	BR5240PN16-0050
65	2"1/2	PN10/16	BR5240PN16-0065
80	3"	PN10/16	BR5240PN16-0080
100	4"	PN10/16	BR5240PN16-0100
125	5"	PN10/16	BR5240PN16-0125
150	6"	PN10/16	BR5240PN16-0150
200	8"	PN10	BR5240PN10-0200
250	10"	PN10	BR5240PN10-0250
300	12"	PN10	BR5240PN10-0300
350	14"	PN10	BR5240PN10-0350
400	16"	PN10	BR5240PN10-0400
200	8"	PN16	BR5240PN16-0200
250	10"	PN16	BR5240PN16-0250
300	12"	PN16	BR5240PN16-0300
350	14"	PN16	BR5240PN16-0350
400	16"	PN16	BR5240PN16-0400

BR5200

Bride plate acier forgé PN10/16 - EN 1092-1
 Forged steel flat flange PN10/16 - EN 1092-1



Type : Plate

Type: Flat flange

DN		PN	Ref.
mm	inch		
15	1/2"	PN10/16/25/40	BR5200PN16-0015
20	3/4"	PN10/16/25/40	BR5200PN16-0020
25	1"	PN10/16/25/40	BR5200PN16-0025
32	1"1/4	PN10/16/25/40	BR5200PN16-0032
40	1"1/2	PN10/16/25/40	BR5200PN16-0040
50	2"	PN10/16	BR5200PN16-0050
65	2"1/2	PN10/16	BR5200PN16-0065
80	3"	PN10/16	BR5200PN16-0080
100	4"	PN10/16	BR5200PN16-0100
125	5"	PN10/16	BR5200PN16-0125
150	6"	PN10/16	BR5200PN16-0150
200	8"	PN10	BR5200PN10-0200
250	10"	PN10	BR5200PN10-0250
300	12"	PN10	BR5200PN10-0300
350	14"	PN10	BR5200PN10-0350
400	16"	PN10	BR5200PN10-0400
200	8"	PN16	BR5200PN16-0200
250	10"	PN16	BR5200PN16-0250
300	12"	PN16	BR5200PN16-0300
350	14"	PN16	BR5200PN16-0350
400	16"	PN16	BR5200PN16-0400



J7240

Joint de bride qualité "Oiltec" sans amiante - PN10/16
 "Oiltec" quality abestos free flange gasket - PN10/16



Epaisseur : 2 mm jusqu'au DN 250, 3 mm au delà.
 T° continue : +250°C (se reporter au passeport)
 Feuille de haute qualité composée d'un mélange de fibres minérales résistantes aux T° élevées et de fibres aramidées avec NBR spécial comme liant.

Thickness: 2 mm till DN 250, 3 mm over DN 250.
 Continuous T°: +250°C (check the technical sheet)
 High quality sheet containing mixture of T° resisting mineral & aramid fibres with a special NBR rubber binder.

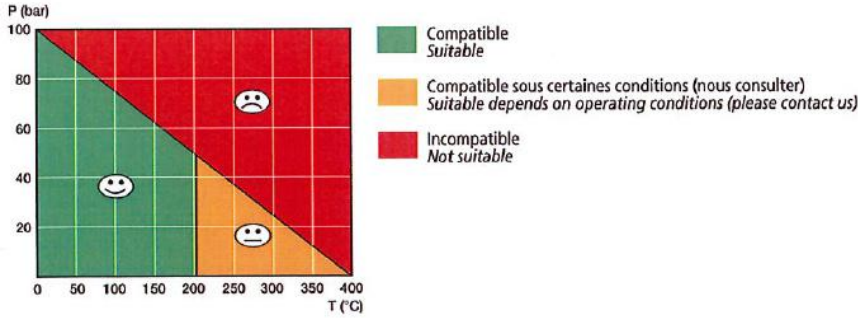

DN		PN	Ref.
mm	inch		
15	1/2"	PN10/16/25/40	J7240PN16-0015
20	3/4"	PN10/16/25/40	J7240PN16-0020
25	1"	PN10/16/25/40	J7240PN16-0025
32	1 1/4"	PN10/16/25/40	J7240PN16-0032
40	1 1/2"	PN10/16/25/40	J7240PN16-0040
50	2"	PN10/16	J7240PN16-0050
65	2 1/2"	PN10/16	J7240PN16-0065
80	3"	PN10/16	J7240PN16-0080
100	4"	PN10/16	J7240PN16-0100
125	5"	PN10/16	J7240PN16-0125
150	6"	PN10/16	J7240PN16-0150
200	8"	PN10/16	J7240PN16-0200
250	10"	PN10	J7240PN10-0250
300	12"	PN10	J7240PN10-0300
350	14"	PN10	J7240PN10-0350
400	16"	PN10	J7240PN10-0400
250	10"	PN16	J7240PN16-0250
300	12"	PN16	J7240PN16-0300
350	14"	PN16	J7240PN16-0350
400	16"	PN16	J7240PN16-0400
500	20"	PN16	J7240PN16-0500
600	24"	PN16	J7240PN16-0600
700	28"	PN16	J7240PN16-0700
800	32"	PN16	J7240PN16-0800
900	36"	PN16	J7240PN16-0900
1000	40"	PN16	J7240PN16-1000

J7240A

Joint de bride EPDM ACS
 EPDM ACS gasket



Epaisseur : 3 mm

Thickness: 3 mm



DN		PN	Ref.
mm	inch		
15	1/2"	PN10/16/25/40	J7240APN16-0015
20	3/4"	PN10/16/25/40	J7240APN16-0020
25	1"	PN10/16/25/40	J7240APN16-0025
32	1 1/4"	PN10/16/25/40	J7240APN16-0032
40	1 1/2"	PN10/16/25/40	J7240APN16-0040
50	2"	PN10/16	J7240APN16-0050
65	2 1/2"	PN10/16	J7240APN16-0065
80	3"	PN10/16	J7240APN16-0080
100	4"	PN10/16	J7240APN16-0100
125	5"	PN10/16	J7240APN16-0125
150	6"	PN10/16	J7240APN16-0150
200	8"	PN10/16	J7240APN16-0200
250	10"	PN10	J7240APN10-0250
300	12"	PN10	J7240APN10-0300
350	14"	PN10	J7240APN10-0350
400	16"	PN10	J7240APN10-0400
450	18"	PN10	J7240APN10-0450
500	20"	PN10	J7240APN10-0500
600	24"	PN10	J7240APN10-0600
250	10"	PN16	J7240APN16-0250
300	12"	PN16	J7240APN16-0300
350	14"	PN16	J7240APN16-0350
400	16"	PN16	J7240APN16-0400
450	18"	PN16	J7240APN16-0450
500	20"	PN16	J7240APN16-0500
600	24"	PN16	J7240APN16-0600

EQBRCACGSTD

Equipement pour appareils de robinetterie standard à brides
Equipment for standard valves



Composé de :

- 2 brides à collerette acier au carbone
- 2 joints sans amiante qualité "Oiltec"
- Boulonnerie acier zingué Classe 8.8

Comprised of:

- 2 carbon steel welding neck flanges
- 2 «Oiltec» quality asbestos free gaskets
- Zinc steel bolts & nuts Grade 8.8

DN		PN	Ref.
mm	inch		
15	1/2"	PN10/16/25/40	EQBRCACGSTD16-0015
20	3/4"	PN10/16/25/40	EQBRCACGSTD16-0020
25	1"	PN10/16/25/40	EQBRCACGSTD16-0025
32	1 1/4"	PN10/16/25/40	EQBRCACGSTD16-0032
40	1 1/2"	PN10/16/25/40	EQBRCACGSTD16-0040
50	2"	PN10/16	EQBRCACGSTD16-0050
65	2 1/2"	PN10/16	EQBRCACGSTD16-0065
80	3"	PN10/16	EQBRCACGSTD16-0080
100	4"	PN10/16	EQBRCACGSTD16-0100
125	5"	PN10/16	EQBRCACGSTD16-0125
150	6"	PN10/16	EQBRCACGSTD16-0150
200	8"	PN10	EQBRCACGSTD10-0200
250	10"	PN10	EQBRCACGSTD10-0250
300	12"	PN10	EQBRCACGSTD10-0300
350	14"	PN10	EQBRCACGSTD10-0350
400	16"	PN10	EQBRCACGSTD10-0400
200	8"	PN16	EQBRCACGSTD16-0200
250	10"	PN16	EQBRCACGSTD16-0250
300	12"	PN16	EQBRCACGSTD16-0300
350	14"	PN16	EQBRCACGSTD16-0350
400	16"	PN16	EQBRCACGSTD16-0400

EQBRCACGVPW

Equipement pour vannes papillon oreilles de centrage
Equipment for wafer butterfly valves



Composé de :

- 2 brides à collerette acier au carbone
- Boulonnerie acier zingué Classe 8.8

Comprised of:

- 2 carbon steel welding neck flanges
- Zinc steel bolts & nuts Grade 8.8

DN		PN	Ref.
mm	inch		
40	1 1/2"	PN10/16	EQBRCACGVPW16-0040
50	2"	PN10/16	EQBRCACGVPW16-0050
65	2 1/2"	PN10/16	EQBRCACGVPW16-0065
80	3"	PN10/16	EQBRCACGVPW16-0080
100	4"	PN10/16	EQBRCACGVPW16-0100
125	5"	PN10/16	EQBRCACGVPW16-0125
150	6"	PN10/16	EQBRCACGVPW16-0150
200	8"	PN16	EQBRCACGVPW16-0200
250	10"	PN16	EQBRCACGVPW16-0250
300	12"	PN16	EQBRCACGVPW16-0300
350	14"	PN10	EQBRCACGVPW10-0350
400	16"	PN10	EQBRCACGVPW10-0400
350	14"	PN16	EQBRCACGVPW16-0350
400	16"	PN16	EQBRCACGVPW16-0400

EQBRCACGVPL

Equipement pour vannes papillon oreilles taraudées
Equipment for lug type butterfly valves



Composé de :

- 2 brides à collerette acier au carbone
- Visserie acier zingué Classe 8.8

Comprised of:

- 2 carbon steel welding neck flanges
- Zinc steel bolts & nuts Grade 8.8

DN		PN	Ref.
mm	inch		
40	1 1/2"	PN10/16	EQBRCACGVPL16-0040
50	2"	PN10/16	EQBRCACGVPL16-0050
65	2 1/2"	PN10/16	EQBRCACGVPL16-0065
80	3"	PN10/16	EQBRCACGVPL16-0080
100	4"	PN10/16	EQBRCACGVPL16-0100
125	5"	PN10/16	EQBRCACGVPL16-0125
150	6"	PN10/16	EQBRCACGVPL16-0150
200	8"	PN10	EQBRCACGVPL10-0200
250	10"	PN10	EQBRCACGVPL10-0250
300	12"	PN10	EQBRCACGVPL10-0300
200	8"	PN16	EQBRCACGVPL16-0200
250	10"	PN16	EQBRCACGVPL16-0250
300	12"	PN16	EQBRCACGVPL16-0300



EQBRACGVG

Equipement pour vannes à guillotine
Equipment for knife gate valves

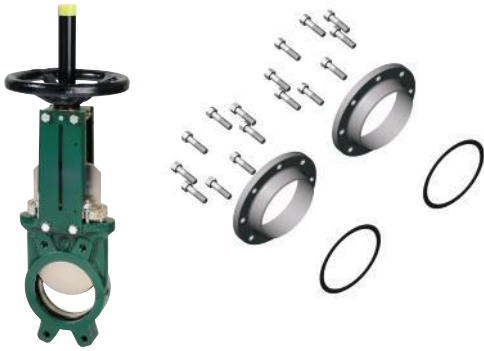

Composé de :
- 2 brides à collerette acier au carbone
- 2 joints sans amiante qualité "Oiltec"
- Boulons et vis acier zingué Classe 8.8

Comprised of:
- 2 carbon steel welding neck flanges
- 2 "Oiltec" quality asbestos free gaskets
- Zinc steel screws, bolts & nuts Grade 8.8

DN		PN	Ref.
mm	inch		
50	2"	PN10/16/25/40	EQBRACGVG16-0050
65	2 1/2"	PN10/16/25/40	EQBRACGVG16-0065
80	3"	PN10/16/25/40	EQBRACGVG16-0080
100	4"	PN10/16/25/40	EQBRACGVG16-0100
125	5"	PN10/16/25/40	EQBRACGVG16-0125
150	6"	PN10/16	EQBRACGVG16-0150
200	8"	PN10	EQBRACGVG10-0200
250	10"	PN10	EQBRACGVG10-0250
300	12"	PN10	EQBRACGVG10-0300
350	14"	PN10	EQBRACGVG10-0350
400	16"	PN10	EQBRACGVG10-0400

EQBRACGCB16

Equipement pour clapets à double battants
Equipment for dual plates check valves



Composé de :
- 2 brides à collerette acier au carbone
- 2 joints sans amiante qualité "Oiltec"
- Boulonnerie acier zingué Classe 8.8

Comprised of:
- 2 carbon steel welding neck flanges
- 2 "Oiltec" quality asbestos free gaskets
- Zinc steel bolts & nuts Grade 8.8

DN		PN	Ref.
mm	inch		
40	1 1/2"	PN10/16	EQBRACGCB16-0040
50	2"	PN10/16	EQBRACGCB16-0050
65	2 1/2"	PN10/16	EQBRACGCB16-0065
80	3"	PN10/16	EQBRACGCB16-0080
100	4"	PN10/16	EQBRACGCB16-0100
125	5"	PN10/16	EQBRACGCB16-0125
150	6"	PN10/16	EQBRACGCB16-0150
200	8"	PN16	EQBRACGCB16-0200
250	10"	PN16	EQBRACGCB16-0250
300	12"	PN16	EQBRACGCB16-0300
350	14"	PN16	EQBRACGCB16-0350
400	16"	PN16	EQBRACGCB16-0400

EQBRACGCB16

Equipement pour clapets à simple battant
Equipment for single swing check valves

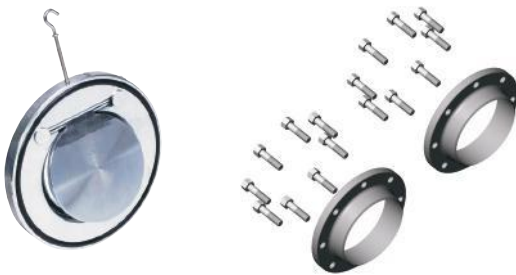

Composé de :
- 2 brides à collerette acier au carbone
- Boulonnerie acier zingué Classe 8.8

Comprised of:
- 2 carbon steel welding neck flanges
- Zinc steel bolts & nuts Grade 8.8

DN		PN	Ref.
mm	inch		
40	1 1/2"	PN10/16	EQBRACGCB16-0040
50	2"	PN10/16	EQBRACGCB16-0050
65	2 1/2"	PN10/16	EQBRACGCB16-0065
80	3"	PN10/16	EQBRACGCB16-0080
100	4"	PN10/16	EQBRACGCB16-0100
125	5"	PN10/16	EQBRACGCB16-0125
150	6"	PN10/16	EQBRACGCB16-0150
200	8"	PN16	EQBRACGCB16-0200
250	10"	PN16	EQBRACGCB16-0250
300	12"	PN16	EQBRACGCB16-0300
350	14"	PN16	EQBRACGCB16-0350
400	16"	PN16	EQBRACGCB16-0400

EQBRACGDI

Equipement pour compensateurs de dilatation
Equipment for expansion joints



Composé de :
- 2 brides à collerette acier au carbone
- Boulonnerie acier zingué Classe 8.8

Comprised of:
- 2 forged steel welding neck flanges
- Zinc steel bolts & nuts Grade 8.8

DN		PN	Ref.
mm	inch		
32	1 1/4"	PN10/16	EQBRACGDI16-0032
40	1 1/2"	PN10/16	EQBRACGDI16-0040
50	2"	PN10/16	EQBRACGDI16-0050
65	2 1/2"	PN10/16	EQBRACGDI16-0065
80	3"	PN10/16	EQBRACGDI16-0080
100	4"	PN10/16	EQBRACGDI16-0100
125	5"	PN10/16	EQBRACGDI16-0125
150	6"	PN10/16	EQBRACGDI16-0150
200	8"	PN10	EQBRACGDI10-0200
250	10"	PN10	EQBRACGDI10-0250
300	12"	PN10	EQBRACGDI10-0300
200	8"	PN16	EQBRACGDI16-0200
250	10"	PN16	EQBRACGDI16-0250
300	12"	PN16	EQBRACGDI16-0300

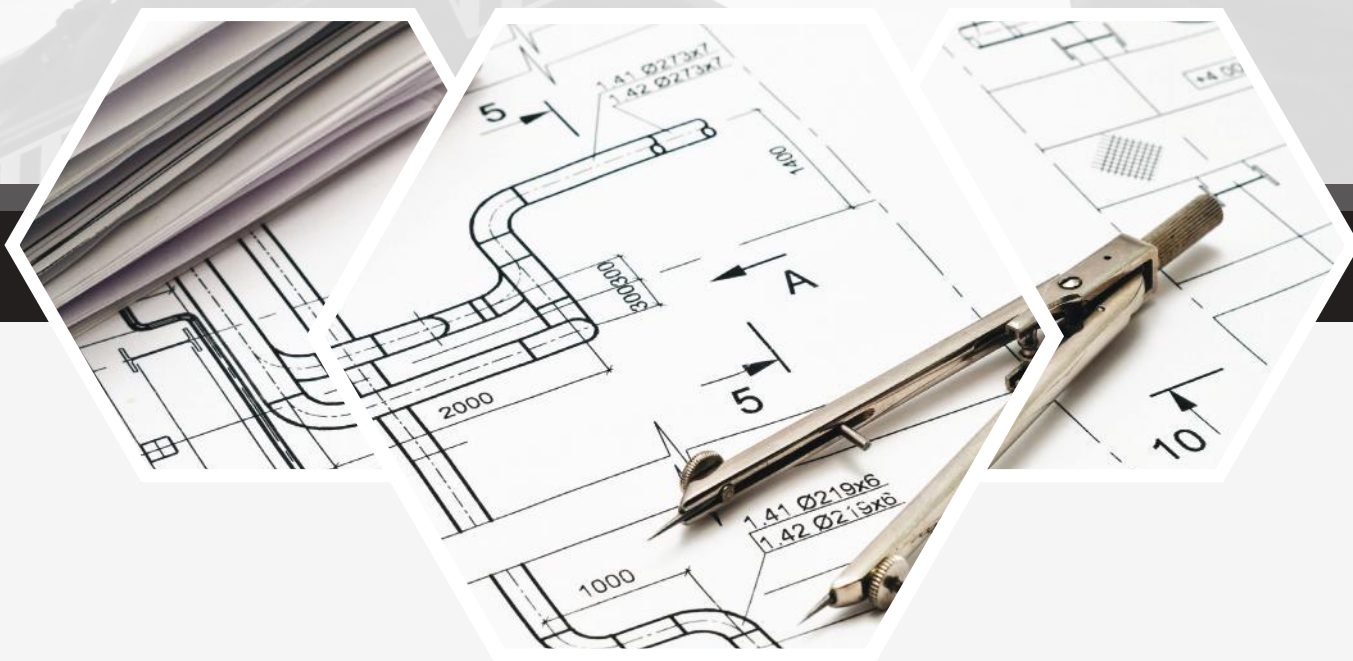



GUIDE TECHNIQUE TECHNICAL BOOK

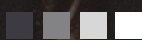





Tecofi'Φ
VALVE DESIGNER - FRANCE

TECHNIQUE DE CONDITIONNEMENT DES FLUIDES
FLUID PROCESSING TECHNIQUE

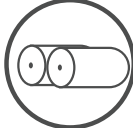

NOS GAMMES SONT ADAPTÉES À CHAQUE SECTEUR D'ACTIVITÉ

PRODUCT RANGES ADAPTED TO EACH LINE OF BUSINESS

SECTEURS D'ACTIVITÉS OUR AREAS OF EXPERTISE	GAMMES DE PRODUITS / RANGE OF PRODUCTS
 <p>EAU Water</p>	<ul style="list-style-type: none"> • Vannes à papillon / <i>Butterfly valves</i> • Vannes à guillotine / <i>Knife gate valves</i> • Vannes murales / <i>Penstocks</i> • Clapets / <i>Check valves</i> • Filtres boîte à boue / <i>H-strainer</i> • Filtres / <i>Strainers</i> • Vannes passage direct / <i>Gate valves</i> • Ventouses / <i>Air release valves</i> • Raccords / <i>Couplings</i> • Compensateurs / <i>Expansion joints</i> • Soupapes de décharge / <i>Safety discharge valves</i> • Robinets boisseau sphérique / <i>Ball valves</i> • Instrumentation / <i>Instrumentation</i> • Joints de démontage / <i>Dismantling joints</i>
 <p>PAPETERIE Paper Industry</p>	<ul style="list-style-type: none"> • Vannes à papillon (Haute performance, à manchette, wafer...) / <i>Butterfly valves (High performance, lined, wafer type...)</i> • Vannes à guillotine (Fonte, inox, à volant, à vérin, bidirectionnelle, pelle traversante...) / <i>Knife gate valves (Cast iron, Stainless steel, with handwheel or actuator, bidirectional, through type...)</i> • Robinets boisseau sphérique / <i>Ball valves</i>
 <p>INDUSTRIE Industry</p>	<ul style="list-style-type: none"> • Vannes à papillon / <i>Butterfly valves</i> • Vannes à guillotine / <i>Knife gate valves</i> • Vannes à passage direct / <i>Gate valves</i> • Compensateurs / <i>Expansion joints</i> • Robinets à soupape / <i>Globe valves</i> • Robinets boisseau sphérique / <i>Ball valves</i> • Soupapes de sécurité / <i>Safety valves</i> • Instrumentation / <i>Instrumentation</i>
 <p>BIOGAZ Biogas</p>	<ul style="list-style-type: none"> • Vannes à papillon / <i>Butterfly valves</i> • Vannes à guillotine / <i>Knife gate valves</i> • Compensateurs / <i>Expansion joints</i> • Robinets boisseau sphérique / <i>Ball valves</i>
 <p>GÉNIE CLIMATIQUE HVAC</p>	<ul style="list-style-type: none"> • Vannes à papillon / <i>Butterfly valves</i> • Vannes à passage direct / <i>Gate valves</i> • Filtres / <i>Strainers</i> • Robinets d'équilibrage / <i>Balancing valves</i> • Robinets boisseau sphérique / <i>Ball valves</i> • Robinets boisseau sphérique / <i>Ball valves</i> • Vannes bronze / <i>Bronze valves</i> • Compensateurs / <i>Expansion joints</i> • Instrumentation / <i>Instrumentation</i>
 <p>MINES Mines</p>	<ul style="list-style-type: none"> • Vannes à guillotine à manchon spéciales produits abrasifs / <i>Pinch knife gate valves special abrasive products</i> • Vannes à papillon / <i>Butterfly valves</i> • Vannes à manchon / <i>Pinch valves</i> • Vannes à passage direct / <i>Gate valves</i>

FONCTION D'UN ROBINET

VALVE FUNCTION

1. FONCTION PRINCIPALE

Main Functions

A / SECTIONNER UN ÉCOULEMENT
On / Off

B / ASSURER UN RÉGLAGE
Regulation

A / SECTIONNER UN ÉCOULEMENT ET
B / ASSURER UN RÉGLAGE
On / Off and Regulation

ROBINET VANNE PASSAGE DIRECT
ROBINET VANNE À PAPILLON
ROBINET BOISSEAU SPHÉRIQUE
ROBINET VANNE À GUILLOTINE

ROBINET À SOUPAPE
ROBINET À MEMBRANE
(Passage à seuil)
ROBINET À POINTEAU
ROBINET VANNE À PAPILLON

ROBINET À MEMBRANE
(Passage à seuil)
ROBINET VANNE À PAPILLON
ROBINET À SOUPAPE
ROBINET VANNE À GUILLOTINE
AVEC «V» DE RÉGULATION

GATE VALVES
BUTTERFLY VALVES
BALL VALVES
KNIFE GATE VALVES







GLOBE VALVES
WEIR TYPE DIAPHRAGM VALVES
NEEDLE VALVES
BUTTERFLY VALVES

WEIR TYPE DIAPHRAGM VALVES
BUTTERFLY VALVES
GLOBE VALVES
KNIFE GATE VALVES WITH «V»
DEFLECTOR



MATÉRIAUX CORPS ET CHAPEAU

BODY AND BONNET MATERIAL

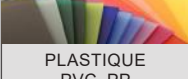
MATÉRIAUX MATERIAL	AVANTAGES ADVANTAGES		INCONVÉNIENTS DISADVANTAGES	
	PRIX PRICE	APPLICATION	PRIX PRICE	APPLICATION
 LAITON Brass	€	(Cuivre + zinc) / (Copper + zinc) • Idéal pour petit diamètre / Ideal for small diameters • Pas fragile / Not breakable • Ne rouille pas / Does not rust • Jetable / Disposable		• Maximum DN100 / Maximum DN100 • Produits corrosifs à exclure (ammoniac exclue sur les alliages cuivreux) / Not suitable for corrosive products • Ne résiste pas à l'acide / Not acid resistant • Basse pression / Low pressure
 BRONZE Bronze		(cuivre + étain) / (Copper + tin) • Pression PN40 / Pressure PN40 • Pas fragile / Not breakable • Ne rouille pas / Does not rust • Utilisé pour les petits et moyens diamètres / For small and medium sized diameters	€€	• Produits corrosifs à exclure (ammoniac exclue sur les alliages cuivreux) / Not suitable for corrosive products (ammoniac forbidden on copper alloys)
 FONTE GRISE Cast Iron	€	• Se moule bien d'où pièces saines, usage assez étendu : eau, vapeur (T ≤ 184°C), gaz, air / Molds well, extensive uses: water, steam (T ≤ 184°C), gas, air. • Ne se plie pas / Does not bend		• Fragile aux chocs / Breakable • Vapeur saturée - Pression limitée à 10 bar 180°C (France) / Saturated steam - pressure limited to 10 bars 180°C in France • Corrosion en surface / Surface corrosion
 FONTE GS (graphite sphéroïdale) Ductile Iron		• Pas fragile, léger / Not breakable, light weight • Bonne tenue : à la corrosion, aux frottements, aux amortissements, aux vibrations. Les caractéristiques mécaniques se rapprochent de celles de l'acier / Good resistance to corrosion, friction and vibrations. Similar mechanical characteristics to steel.	€€	• Soudage difficile / difficult welding • Limité à PN16 / Limited to PN16 • Corrosion en surface / Surface corrosion
 ACIER AU CARBONE Carbon Steel		• Plus résistant que fonte GS. Utilisation : à températures plus étendues : -20 ≤ T ≤ 425°C à pression plus importantes : P ≤ 400bars / More resistant than ductile iron. Use: wider range of temperatures : -20 ≤ T ≤ 425°C at higher pressures : P ≤ 400 bars	€€	• Mauvaise tenue à la corrosion / Low resistance to corrosion • Corrosion en profondeur / Deep corrosion
 INOX Stainless Steel		(acier+chrome) / (Steel + chrome) • Température d'utilisation / Working temperature : -200°C ≤ T ≤ +500°C • Tenue à la corrosion / Good resistance to corrosion	€€	• Coût élevé / Expensive • Corrosion en profondeur / Deep corrosion • Poids / Weight
 DUPLEX SUPER DUPLEX Special Stainless Steel		• Température élevée à vérifier avec le type de matériaux / Suitable for high temperatures, depending on the type of material • Très bonne résistance corrosion / Very good resistance to corrosion • Utilisation eau de mer / Sea water resistant	€€€	• Coût élevé / Expensive
 PLASTIQUE PVC, PP Plastic		• Maxi PN16 / Max PN16 • Ne rouille pas / Does not rust • Léger / Light weight	€	• Résistance limitée à la température / Low tolerance to temperature

€ : peu coûteux / affordable

€€ : coûteux / expensive

€€€ : très coûteux / very expensive

CORPS ET CHAPEAU BODY AND BONNET

Situer l'appareil de robinetterie selon les pressions et les températures :
Consider the valve according to pressure and temperature :

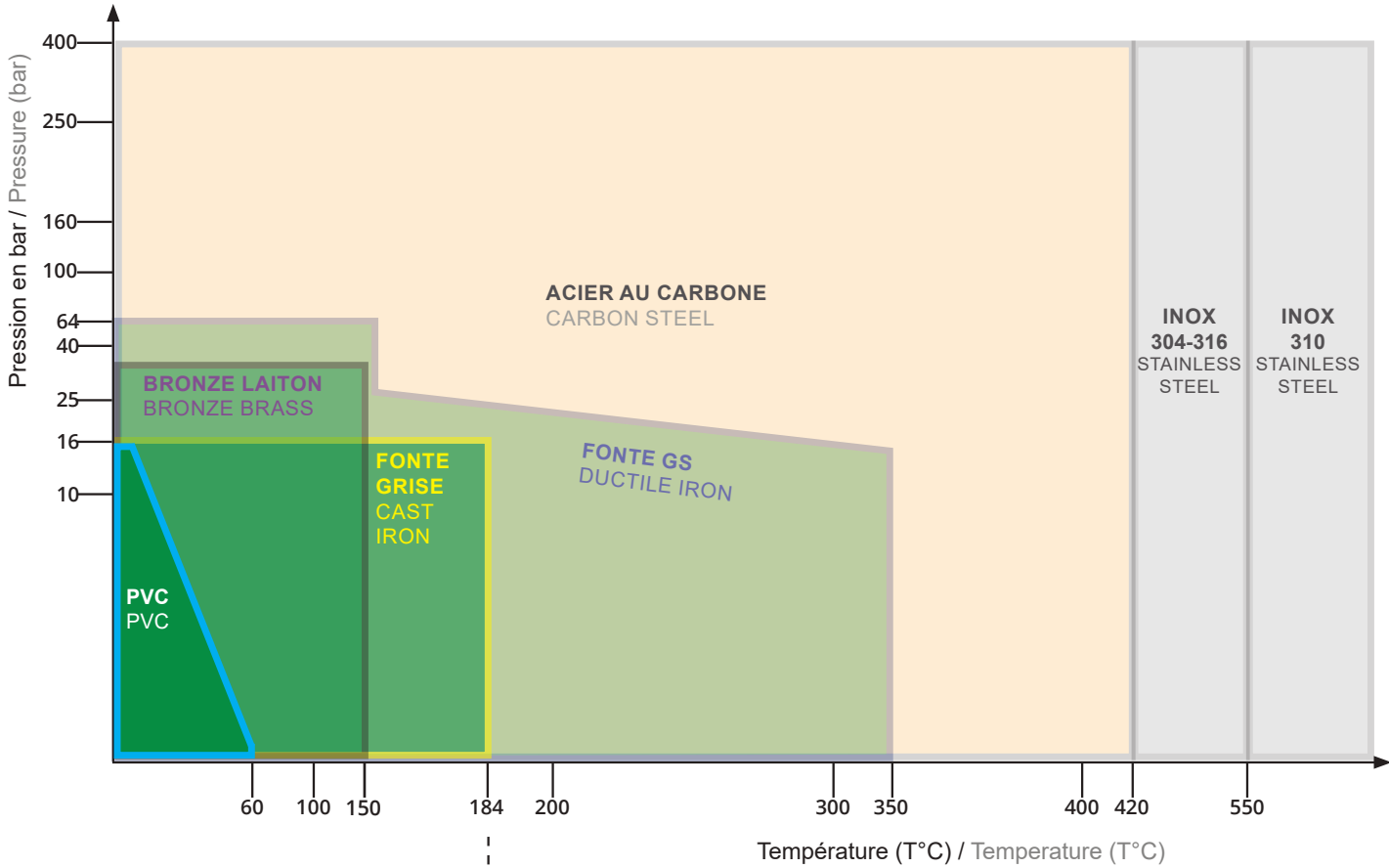

Limite de la fonte grise pour vapeur 10 bar / 180°C
Limit of cast iron for steam 10 bar / 180°C

Rappel / Reminder

1 BAR = 1Kg / cm²

Aire du disque = $\frac{\pi D^2}{4}$
Disc area

Exemples de pression / Examples of pressure

- . Eau distribution habitation / Residential water supply = 3/4 bar
- . Pneu voiture / Car tire = 2,5 bar
- . Circuit de chauffage / Heating circuit = 1 - 2 bar

Exemple de situation : calcul de la pression sur un obturateur

Example: calculation of the pressure on the obturator

Vanne / valve DN100 16 bar = 16Kg par cm²





Force de l'eau sur le papillon / Water force on the disc : $3,14 \times 10 \times 10 / 4 = 78,5 \text{cm}^2 \times 16 = 1\ 256 \text{Kg}$

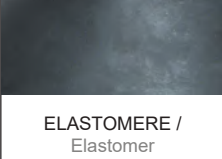

PORTAGE SEAL SURFACE

Pour définir le bon équipement, il faut bien prendre en compte les éléments d'étanchéité interne (du portage et du chapeau) en contact avec le fluide.

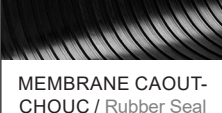
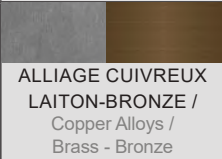
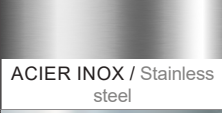
To choose the right equipment, it is necessary to take into account the internal sealing elements (of the body and the bonnet) in contact with the fluid.

MATÉRIAUX MATERIAL	AVANTAGES ADVANTAGES		INCONVÉNIENTS DISADVANTAGES	
	PRIX PRICE	APPLICATION	PRIX PRICE	APPLICATION
 ELASTOMERE / Elastomer	€	<ul style="list-style-type: none"> Silencieux (utilisé sur clapet) / Silent Étanchéité efficace / Effective sealing 		Suivant type d'élastomère / Depending on the type of elastomer: Température max. 120°C (suivant le caoutchouc) / Max temperature : 120°C • Résiste mal au laminage / Poorly resistant to stretching • Sensible aux phénomènes d'érosion et de corrosion / Low resistance to corrosion
 PTFE (Teflon®)		<ul style="list-style-type: none"> Résistance chimique excellente / Good chemical resistance Coefficient de frottement faible / Low friction coefficient 	€€	<ul style="list-style-type: none"> Limité en température / Max temperature : Vierge 200°C / PTFE : 200°C Chargé verre 220 °C / PTFE+Glass : 220°C Interdit aux centrales nucléaires / Prohibited at nuclear power plants
 MEMBRANE CAOUT- CHOUC / Rubber Seal	€	<ul style="list-style-type: none"> Étanchéité parfaite même avec faibles particules solides coincées entre obturateur et corps / Perfect tightness even with particles stuck between body and obturator. 		<ul style="list-style-type: none"> Usage limité en température : T ≤ 130°C / Max temperature : T ≤ 130°C
 ALLIAGE CUIVREUX LAITON-BRONZE / Copper Alloys / Brass - Bronze		<ul style="list-style-type: none"> Utilisation sur température pouvant atteindre 200°C à 16 bars / Working conditions : up to 200°C at 16 bars Bonnes propriétés de frottement / Low friction coefficient 	€€	<ul style="list-style-type: none"> Étanchéité plus difficilement obtenue / Tightness not easily achieved
 ACIER INOX / Stainless steel		<ul style="list-style-type: none"> Utilisation à température assez élevée / High working temperature : T ≥ 420°C 	€€	<ul style="list-style-type: none"> Étanchéité assez difficile à obtenir, rectification rodage/ Tightness fairly difficult to achieve
 STELLITE		<ul style="list-style-type: none"> Alliage dur permettant une étanchéité excellente à pressions et températures élevées / Perfect tightness at high pressures and temperatures 	€€€	<ul style="list-style-type: none"> Utilisation conditions sévères, abrasions / Use in difficult conditions, abrasions

€ : peu coûteux / affordable
 €€ : coûteux / expensive
 €€€ : très coûteux / very expensive

RÉSISTANCE PRESSION / TEMPÉRATURE DU PORTAGE SEALING PRESSURE / TEMPERATURE RESISTANCE

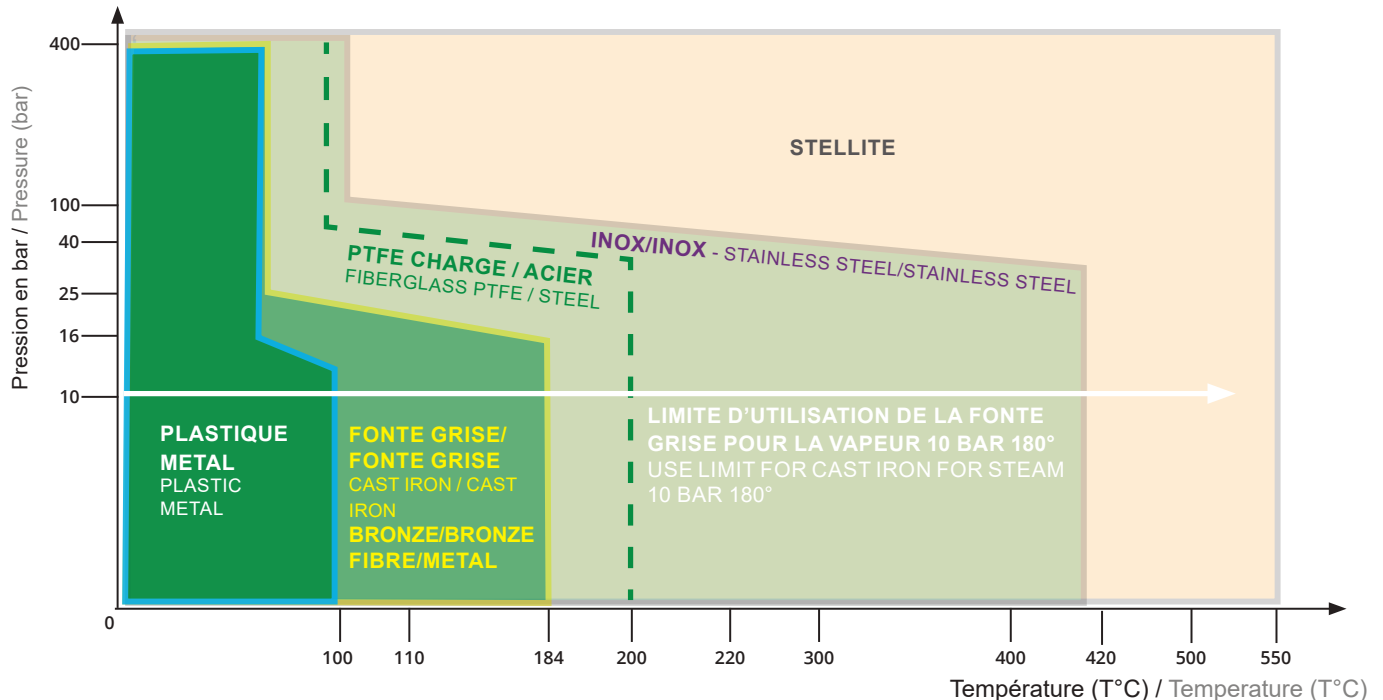

CORRESPONDANCE NORMES

STANDARD EQUIVALENCES

MATÉRIAUX MATERIAL	NORME EN EN NORM	NUMÉRIQUE DIGITAL	NORME AFNOR AFNOR NORM	NORME DIN DIN NORM	NORME ASTM ASTM NORM
Fonte grise <i>Cast iron</i>	EN-GJL-250 (NF EN 1561)	5.1301 (EN 1561)	FGL 250 (NF A 32-101) Ft 25	GG 25 (DIN 1691)	
Fonte GS <i>Ductile iron</i>	EN-GJS-400-15 (NF EN 1563)	5.3106 (NF EN 1563)	FGS 400-15 (NF A 32-201)	GGG 40 (DIN 1693)	A536 65-45-12
Fonte GS <i>Ductile iron</i>	EN-GJS-500-7 (NF EN 1563)	5.3200 (NF EN 1563)	FGS 500-7 (NF A 32-201)	GGG 50 (DIN 1693)	
Inox 304 moulé <i>Molded SS304</i>	GX5CrNi 19-10 (NF EN 10213-4)	1.4308	Z6CN 18-10 (NF A 32-055)	G-X6CrNi 18 9 (DIN 17-445)	Grade CF8 (ASTM A 351)
Inox 304 laminé <i>Rolled SS304</i>	X5CrNi 18-10 (NF EN 10028-7)	1.4301	Z7CN 18-09 (NF A 36-209)	X5CrNi 18-10 (DIN 17-440)	AISI 304 (ASTM A 182)
Inox 316 moulé <i>Molded SS316</i>	GX5CrNiMo 19-11-2 (NF EN 10213-4)	1.4408	Z6 CND 18-12	G-X6CrNiMo 18 10 (DIN 17-445)	Grade CF8M (ASTM A 351)
Inox 316L moulé <i>Molded SS316L</i>	GX2CrNiMo 19-11-2 (NF EN 10213-4)	1.4409	Z2 CND 17-12	1.4409	Grade CF3M (ASTM A 351)
Inox 316 laminé <i>Rolled SS316</i>	X5CrNiMo 17-12-2 (NF EN 10028-7)	1.4401	Z7 CND 17-11-2 (NF A 36-209)	X5CrNiMo 18 10 (DIN 17-440)	AISI 316 (ASTM A 182)
Inox 410 laminé <i>Rolled SS410</i>	X12Cr13 (NF EN 10088-3)	1.4006	Z 10 C13 (NF A 35-574)	1.4006	AISI 410
Inox 310 laminé <i>Rolled SS310</i>	X8CrNi 25-21 (NF EN 10095)	1.4845	Z 8 CN 25-20 (NF A 36-209)	1.4845	AISI 310
Inox 420 <i>SS420</i>	X20Cr13 (NF EN 10088-3)	1.4021	Z 20 C13 (NF A 35-574)	1.4021	AISI 420 (ASTM A 276)
Acier laminé <i>Rolled steel</i>	P265GH (NF EN 10028-2)	1.0425	A42FP (NF A 36-205)	H11 (DIN 17155)	ASTM A216 Grade WCA
Acier moulé <i>Molded steel</i>	GP240GH (NF EN 10213-2)	1.0619	A 420 CPM	GS-C25 (DIN 17245)	ASTM A216 Grade WCA
Acier carbone <i>Carbon steel</i>		1.0619	A 48 CM (A 32-055)	GS-C25 (DIN 17245)	ASTM A216 Grade WCB
Bronze	CuSn5Zn5Pb5-C (NF EN 1982)	CC491K	CuSn5Zn5Pb5 (NFA 53-707)	G-CuSn5PbZn(Rg5) 2.1096.01 (DIN 1705)	C83600 (ASTM B62)



TEMPÉRATURE TEMPERATURE

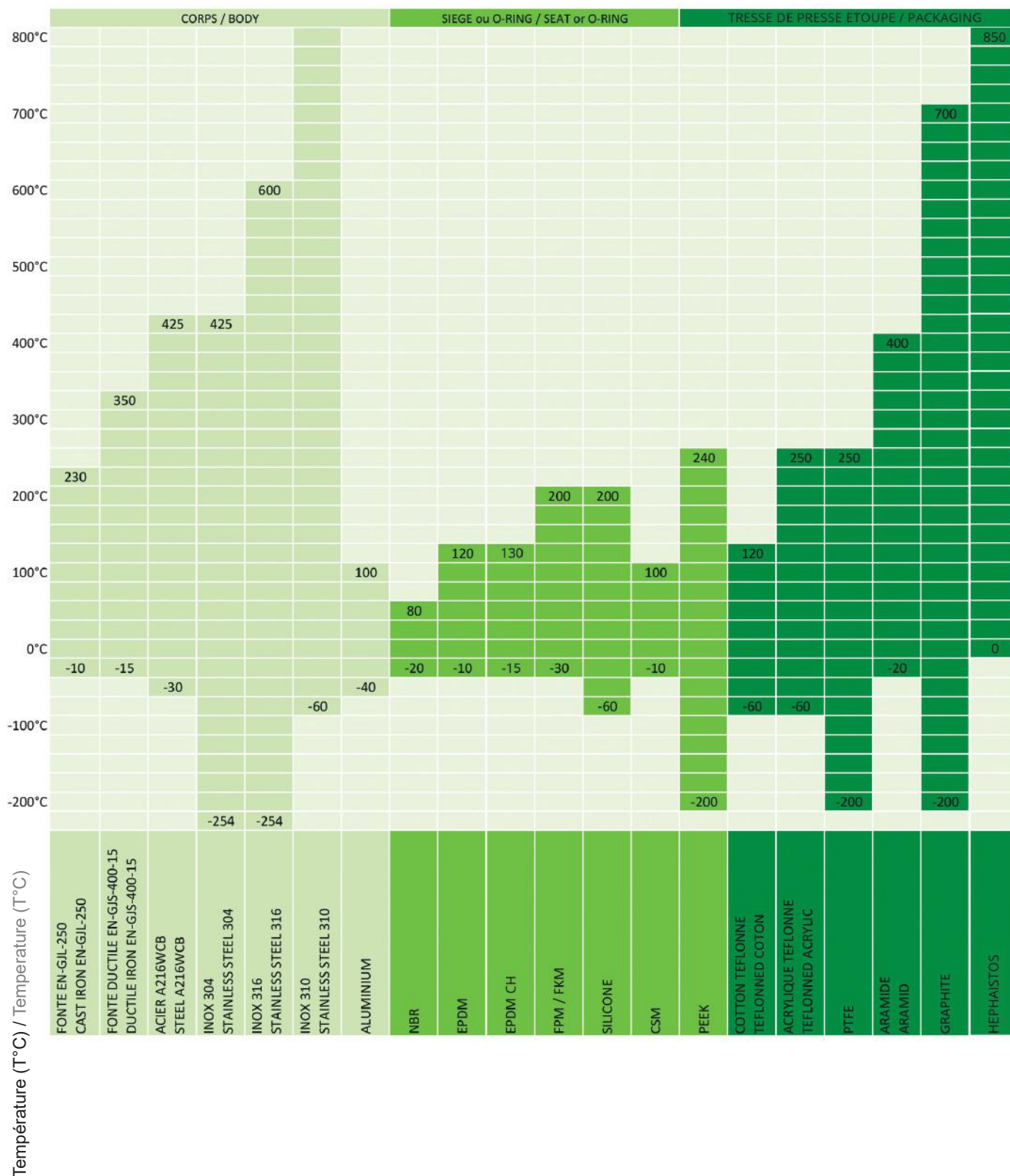

MÉCANIQUE DES FLUIDES

FLUID MECHANICS

CLASSIFICATION PAR RELATIONS

PRESSIONS / TEMPÉRATURE

Un des apports fondamentaux de la normalisation en matière de robinetterie concerne le domaine d'utilisation des appareils défini dans un diagramme comportant en abscisse la température en degrés centigrades et en ordonnée la pression exprimée en bar.

Les courbes «pression-température» sont spécifiques au matériau constitutif de l'enveloppe. Il faut noter, en particulier, des restrictions draconiennes d'emploi sont édictées par la réglementation pour l'utilisation de la fonte grise non alliée, en raison de sa faible résilience.

CLASSIFICATION BY RELATION

PRESSURE/TEMPERATURE

The appliance's type of use is one of the fundamental factors in valve material standardization, which is defined in a graph showing the temperature in degrees celsius on the x axis and the pressure in bars on the x axis.

The curves "pressure-temperature" are specific to each material making up the envelope. It should be noted that in particular the severe use restrictions are based on the use of non-alloy cast iron, due to its weak resilience.

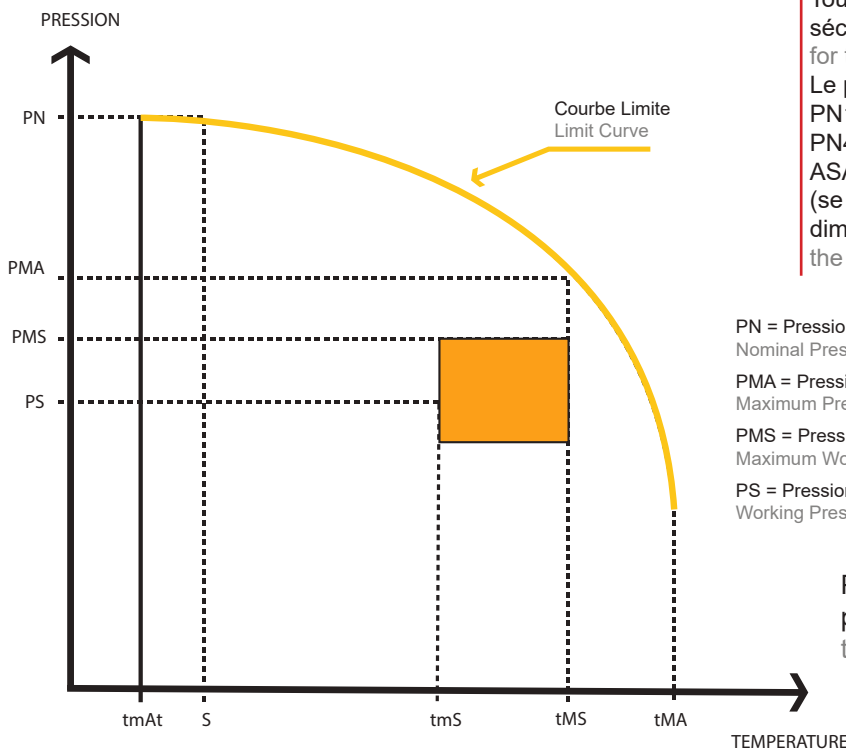

ATTENTION / WARNING

Toujours préconiser le PN avec une marge de sécurité. / Always leave a margin of security for the nominal pressure.

Le palier normalisé / The standardized tiers
 PN10 / 16 / 20 / 25
 PN40 / 50 / 63 / 100
 ASA 150 / 300 / 600...

(se référer au tableau des normes sur les dimensions des brides et boulons) / (refer to the flange and bolt dimension norms table)

PN = Pression Nominale
 Nominal Pressure

PMA = Pression Maxi Admissible
 Maximum Pressure Permitted

PMS = Pression Maxi Service
 Maximum Working Pressure

PS = Pression de Service
 Working Pressure

tS = Température de Service
 Working Temperature

tMS = Température Mini de Service
 Minimum Working Temperature

tMS = Température Maxi de Service
 Maximum Working Temperature

tMA = Température Maxi Admissible
 Maximum Temperature Permitted

Plus il y a de T°, moins la vanne résiste en pression / The higher the temperature, the less the valve is resistant to pressure.

CONVERSION DES UNITÉS DE PRESSION / CONVERSION OF UNITS OF PRESSURE

Unités Unit	Atmosphère Atmospheric (atm)	Kg/cm ²	PSI	Pascal	mCE	Bar	mmHg
Atmosphère Atmospheric (atm)	1	1,033	14,69	101.325	0,0968	1,0133	750,19
Kg/cm ²	0,9678	1	14,223	98.087	0,0999	0,981	745,20
PSI	0,068804	0,07031	1	6.896	1,4223	0,069	52,35
Pascal	9,869 x 10 ⁻⁶	10,19 x 10 ⁻⁶	145 x 10 ⁻⁶	1	9808	10 ⁻⁵	0,76
mCE	0,0968	0,0999	1,4223	9808	1	0,0986	7,3554 x 10 ¹
Bar	0,986	1,019	14,5	100.00	0,0986	1	760
mmHg	13,33 x 10 ⁻⁴	13,42 x 10 ⁻⁴	0,0191	1,316	7,3554 x 10 ¹	13,16 x 10 ⁻⁴	1



PERTE DE CHARGE HEAD LOSS

Coefficient de perte de charge. Baisse de pression dans le passage de la vanne
Head loss coefficient

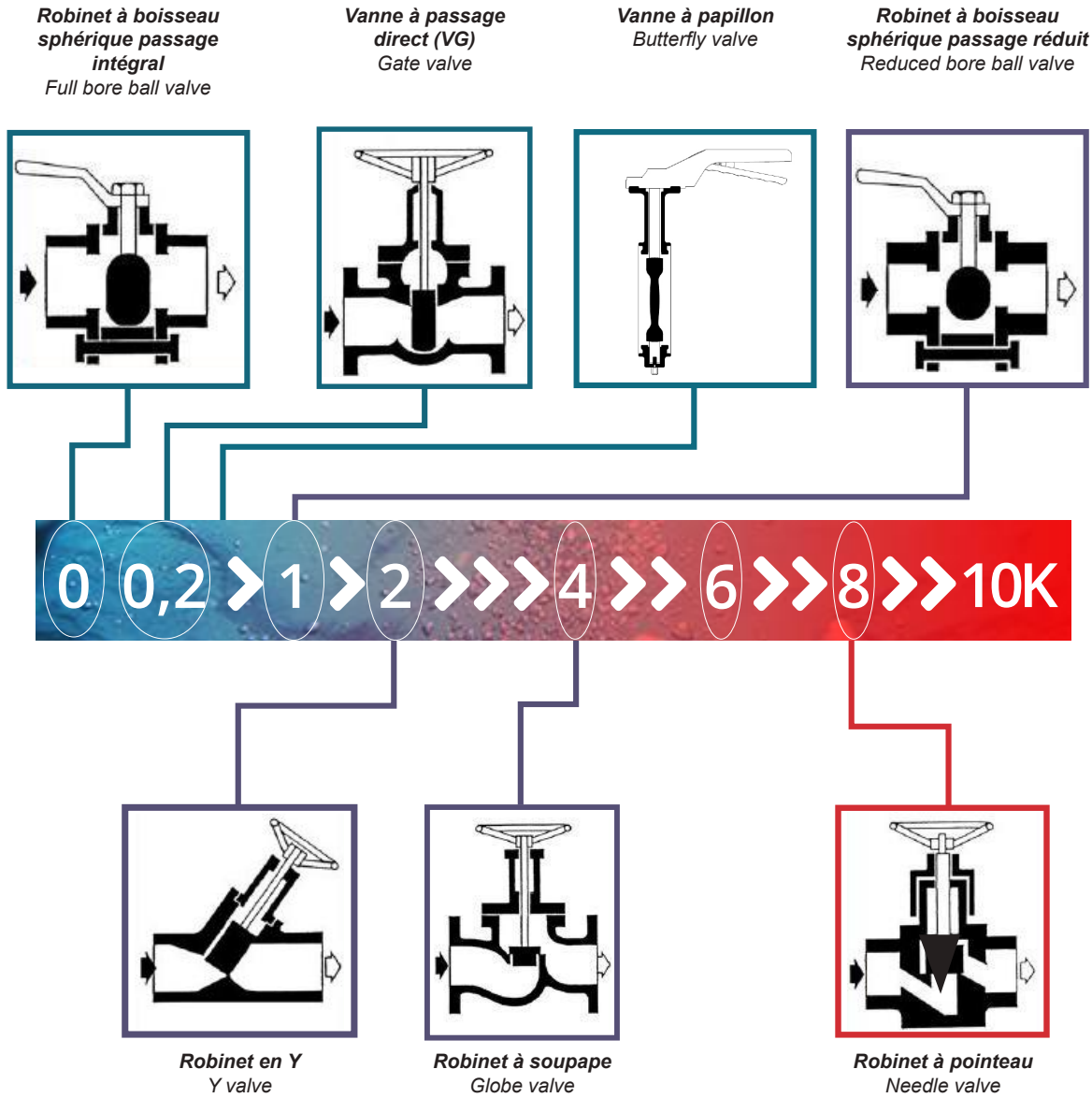

Perte de charge et facteur d'écoulement / Head Loss and Flow Factor

Kv : kv=1, le débit en m³/h qui passe dans un appareil provoquant une perte de charge de 1 bar (Kv valeur intrinsèque de l'appareil) / A flow in m³/h loses 1 bar when passing through an appliance (Kv value intrinsic to the appliance)
Cv : Définition identique au facteur kv, mais mesuré en US-Gallons à 60°F, avec une perte de charge de 1 psi
 Identical to Kv factor, but is measured in U.S. gallons at 60°F, with a head loss of 1 psi

$$kv = \text{pas d'unité} / \text{no unit} \quad Q = Kv \cdot \sqrt{\Delta p} \quad Kv = Q / \sqrt{\Delta p}$$

$$Q = m^3/h \quad \Delta p = Q^2 / Kv^2$$

RACCORDEMENTS CONNECTIONS

Différents types de raccords de la robinetterie sur les tubes.
Connection types for valves.



TABLEAU D'ÉQUIVALENCE DES DIMENSIONS DIMENSION TABLE

DIAMÈTRE NOMINAL NOMINAL DIAMETER mm	RACCORDEMENT ASA* CONNECTION ASA* pouce / inch	Ø EXTÉRIEUR DU TUBE** DIAMETER TUBE EXTERIOR** mm	RACCORDS VISSÉS THREADED CONNECTIONS mm
6	1/8"	10,2	5 x 10
8	1/4"	13,5	8 x 13
10	3/8"	17,2	12 x 17
15	1/2"	21,3	15 x 21
20	3/4"	26,9	20 x 27
25	1"	33,7	26 x 34
32	1"1/4	42,4	33 x 42
40	1"1/2	48,3	40 x 49
50	2"	60,3	50 x 60
(60)	(2"1/4)	(70)	(60 x 70)
65	2"1/2	76,1	66 x 76
80	3"	88,9	80 x 90
(90)	(3"1/2)	101,6	(90 x 102)
100	4"	108 ou 114,3	102 x 114
125	5"	133 ou 139,7	
150	6"	159 ou 168,3	
(175)	(7")	(193,7)	
200	8"	219,1	
(225)	(9")	(244,5)	
250	10"	273	
300	12"	323,9	
350	14"	355,6	
400	16"	406,4	
450	18"	457	
500	20"	506	
600	24"	609,6	
700	28"	711	
800	32"	813	
900	34"	914	
1000	40"	1016	

Vocabulaire / Measurement units :
 . Taraudé / Threading = en pouce / in inches
 . A bride / Flanged = en mm / in mm

* ASMEA B16.34
 ** EN10255 / EN1026-1

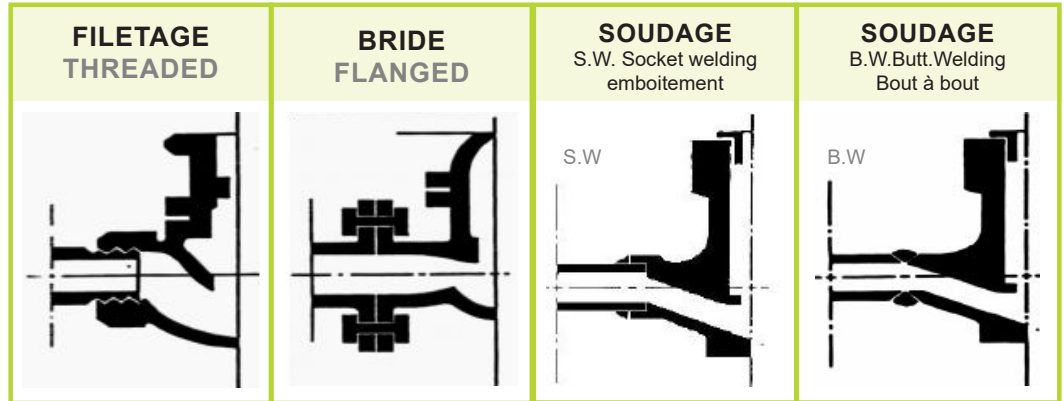

CORRESPONDANCE DES NORMES DES ACIERS FORGÉS

STANDARD EQUIVALENCES FOR FORGED STEEL

ACIERS TYPE OF STEEL	FRANCE FRENCH NF		ETATS-UNIS AMERICAN ASTM	ALLEMAGNE GERMAN DIN		GRANDE-BRETAGNE BRITISH BS
ACIER AU CARBONE CARBON STEEL	BF48, BF48N XC 18 A48 CP	NF E 29-204 NF A 35-552 NF 36-601	A 105	C35 ST 60.2	DIN 17200	1.503.161 nuance C Grade C
ACIER AU CARBONE BASSE TEMPÉRATURE CARBON STEEL LOW TEMPERATURE	BF48 F A48 FP	NF E 29-204 NF A 36-601	A 350 GRADE LF2	TT st 41V wbl 680	DIN 17100	
ACIER AU CARBONE MOLYBDENE MOLYBDENUM CARBON STEEL	BF15 CD2-05	NF E 29-204	A 182 GRADE F1	16 MO 5 Sel 22 MO 4 wbl 550		1.503.240 nuance B Grade B
ACIER AU CHROME MOLYB- DENE CHROMIUM - MOLYBDENUM STEEL	BF15 CD4-05	NF E 29-204	A 182 GRADE F2	13 Cr MO 4-4	DIN 17-155	
ACIER 1% CHROME 0,5% MOLYBDENE STEEL 1% CHROMIUM 0.5% MOLYBDENUM	BF15 CSD5-03-05	NF E 29-204	A 182 GRADE F12	13 Cr MO 4-4	DIN 17-155	1.503.620
ACIER 1,25% CHROME 0,5% MOLYBDENE STEEL 1.25% CHROMIUM 0.5% MOYBDENUM	BF10 CD9-10	NF E 29-204	A 182 GRADE F11	13 Cr MO 4-4	DIN 17-155	1.503.621
ACIER 2,25% CHROME 1% MOLYBDENE STEEL 2.25% CHROMIUM 1% MOLYBDENUM	BFZ10 CD5-05	NF E 29-204	A 182 GRADE F22	10 Cr MO 9-10	DIN 17-155	1.503.622
ACIER 5% CHROME 0,5% MOLYBDENE STEEL 5% CHROMIUM 0.5% MOLYBDENUM	BFZ6 CN 18-09	NF E 29-204	A 182 GRADE F5			1.503.625
ACIER AUSTENITIQUE AU NICKEL-CHROME AUSTENITIC NICKEL-CHRO- MIUM STEEL	BFZ2 CN18-10	NF E 29-204	A 182 GRADE F304	X5 Cr Ni 18-9	DIN 17-440	1.503.801
ACIER AUSTENITIQUE AU NICKEL-CHROME A BAS CARBONE LOW CARBON AUSTENITIC NIC- KEL-CHROMIUM STEEL	BFZ6 CNT18-10	NF E 29-204	A 182 GRADE F304L	X2 Cr Ni 18-9	DIN 17-440	1.503 Nuance 304.S30 Grade 304.S30
ACIER AUSTENITIQUE AU NICKEL-CHROME STABILISE AU TITANE TITANIUM-STABILIZED AUSTENI- TIC NICKEL-CHROMIUM STEEL	BFZ6 CNNb18-10	NF E 29-204	A 182 GRADE F321	X10 Cr Ni Ti 18-9	DIN 17-440	1.503.821 Nuance Ti 321.S40 Grade Ti 321.S40
ACIER AUSTENITIQUE AU NICKEL-CHROME STABILISE AU NIOBIUM NIOBIUM-STABILIZED AUSTENI- TIC NICKEL-CHROMIUM STEEL	BFZ6 CNNb 18-10	NF A 35-574	A 182 GRADE F347	X10 Cr Ni Nb 18-9	DIN 17-440	1.503.821 Nuance Nb 347.S40 Grade Nb 347.S40
ACIER AUSTENITIQUE AU NICKEL-CHROME MOLYBDENE AUSTENITIC NICKEL-CHRO- MIUM MOLYBDENUM STEEL	BFZ6 CND17-11	NF E 29-204	A 182 GRADE F316	X5 Cr Ni Mo 18-10	DIN 17-440	1.503.845 Nuance B 316.S40 Grade B 316.S40
ACIER AUSTENITIQUE AU NICKEL-CHROME MOLYBDENE A BAS CAR- BONE LOW CARBON AUSTENITIC NICKEL- CHROMIUM MOLYBDE- NUM STEEL	BFZ2 CND17-12	NF E 29-204	A 182 GRADE F316L	X2 Cr Ni Mo 18-10	DIN 17-440	1.503 Nuance 316.S40
ACIER 3,5% NICKEL BASSE TEMPÉRATURE LOW TEMPERATURE STEEL 3.5% NICKEL	BF12N4	NF E 29-204	A 350 GRADE LF3	10 Ni 14-16 Ni 14 Wb 680		1.503.503

CORRESPONDANCE ENTRE LA TEMPÉRATURE DE LA VAPEUR D'EAU ET LA PRESSION EFFECTIVE

CORRELATION BETWEEN WATER VAPOR TEMPERATURE AND EFFECTIVE PRESSURE

PRESSION EFFECTIVE EN BAR EFFECTIVE PRESSURE (BAR)	TEMPÉRATURE EN °C TEMPERATURE (C°)
0,5	112
1,0	120
1,5	128
2,0	134
2,5	139
3,0	144
3,5	148
4,0	152
4,5	156
5,0	159
5,5	162
6,0	165
6,5	168
7,0	170
7,5	173
8,0	175
8,5	178
9,0	180
9,5	182
10,0	184
10,5	186
11,0	188
11,5	190
12,0	192
12,5	194
13,0	195
13,5	197
14,0	198
14,5	200
15,0	201
16,0	204
17,0	207
18,0	210
19,0	212
20,0	215
21,0	217
22,0	220
23,0	222
24,0	224

PRESSION EFFECTIVE EN BAR EFFECTIVE PRESSURE (BAR)	TEMPÉRATURE EN °C TEMPERATURE (C°)
25,0	226
26,0	228
27,0	230
28,0	232
29,0	234
30,0	236
31,0	237
32,0	239
33,0	241
34,0	243
35,0	244
36,0	246
37,0	247
38,0	249
39,0	250
40,0	252
45,0	259
50,0	265
55,0	271
60,0	277
65,0	282
70,0	287
75,0	291
80,0	296
85,0	300
90,0	304
95,0	308
100,0	312
105,0	315
110,0	319
115,0	322
120,0	325
125,0	328
130,0	331
135,0	334
140,0	337
145,0	340
150,0	343



PORTÉES DE JOINT POUR BRIDE FACE SURELEVÉE SUIVANT NF E 29203

GASKET SOCKET AND SURFACE ACCORDING TO NF E 29203

DIAMÈTRE NOMINAL NOMINAL DIAMETER	PORTÉES DE JOINT / GASKET SURFACE								
	D1								J
	PRESSIONS NOMINALES PN / NOMINAL PRESSURE PN								
	PN 2,5	PN 6	PN 10	PN 16	PN 25	PN 40	PN 63	PN 100	
10	UTILISER LES DIMENSIONS PN 6	35	UTILISER LES DIMENSIONS PN 6					40	2
15		40	UTILISER LES DIMENSIONS PN 6					45	2
20		50	UTILISER LES DIMENSIONS PN 6					58	2
25		60	UTILISER LES DIMENSIONS PN 6					68	2
32		70	UTILISER LES DIMENSIONS PN 6					78	2
40		80	UTILISER LES DIMENSIONS PN 6					88	2
50		90	UTILISER LES DIMENSIONS PN 6					102	2
65		110	UTILISER LES DIMENSIONS PN 6					122	2
80		128	UTILISER LES DIMENSIONS PN 6					138	2
100			148	158	158	162	162	162	162
125		178	188	188	188	188	188	188	2
150	UTILISER LES DIMENSIONS PN 6	202	212	212	218	218	218	218	2
200		258	268	268	278	285	285	285	2
250		312	320	320	335	345	345	345	2
300		365	370	378	395	410	410	410	2
350		415	430	438	450	465	465	465	2
400		465	482	490	505	535	535	535	2
450		520	532	550	555	560	560	560	2
500		570	585	610	615	615	615	615	2
600		670	685	725	720	735	735	-	2
700		775	800	795	820	-	840	-	2
800	880	905	900	930	-	960	-	2	
900	980	1005	1000	1030	-	1070	-	2	
1000	1080	1110	1115	1140	-	1180	-	2	
1200	1280	1295	1330	1330	1350	-	1380	-	2
1400	1480	1510	1535	1530	1560	-	-	-	2
1600	1690	1710	1760	1750	1780	-	-	-	2
1800	1890	1920	1960	1950	1985	-	-	-	2
2000	2090	2125	2170	2150	2210	-	-	-	2
2200	2295	2335	2370	-	-	-	-	-	2
2400	2495	2545	2570	-	-	-	-	-	2
2600	2695	2750	2780	-	-	-	-	-	2
2800	2910	2960	3000	-	-	-	-	-	2
3000	3110	3160	3210	-	-	-	-	-	2
3200	3310	3370	-	-	-	-	-	-	2
3400	3510	3580	-	-	-	-	-	-	2
3800	3920	-	-	-	-	-	-	-	2
4000	4120	-	-	-	-	-	-	-	2

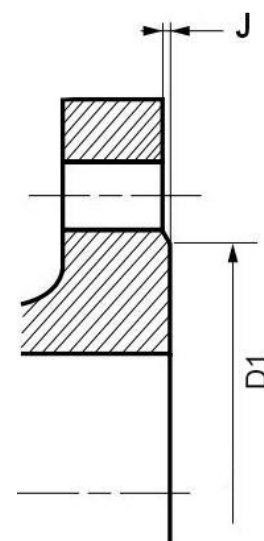

PRINCIPAUX FILETAGES POUR TUYAUX

STANDARD SCREW THREADS

ASTM		DN	ISO	MÉTRIQUE METRIC	SERIE GAZ GAS SERIES NORMALISATION DES FILETAGES SCREW THREAD STANDARDIZATION					
Ø EXTÉRIEUR EXTERIOR (inch) (mm)	Ø NOMINAL (langage brides) FLANGE	Ø EXT. (mm)	Ø EXT. (mm)	DÉNOMINATION DENOMINATION (inch) (mm)	Ø EXT. (mm)	Ø NOYAU CORE (mm)	NOMBRE FILET AU POUCE NUMBER OF THREADS PER INCH	PAS PITCH		
1/8"	10.3	6	10.2		5/10	1/8"	9.73	8.57	28	0.91
1/4"	13.7	8	13.5		8/13	1/4"	13.16	11.45	19	1.34
3/8"	17.1	10	17.2	18	12/17	3/8"	16.66	14.95	19	1.34
1/2"	21.3	15	21.3	23-25	15/21	1/2"	20.95	18.63	14	1.81
3/4"	26.7	20	26.9	28	20/27	3/4"	26.44	24.12	14	1.81
1"	33.4	25	33.7	33.34	26/34	1"	33.25	30.29	11	2.31
1 1/4"	42.2	32	42.4	43-44	33/42	1 1/4"	41.91	38.95	11	2.31
1 1/2"	48.3	40	48.3	53-54	40/49	1 1/2"	47.80	44.85	11	2.31
2"	60.3	50	60.3	63-64	50/60	2"	59.61	56.66	11	2.31
2 1/2"	73.0	65	76.1	73-74	66/76	2 1/2"	75.18	72.23	11	2.31
3"	88.9	80	88.9	83-84	80/90	3"	87.88	84.93	11	2.31
3 1/2"	101.6	90	101.6		90/102	3 1/2"	100.33	97.37	11	2.31
4"	114.3	100	114.3	103-104	102/114	4"	113.03	110.07	11	2.31
5"	141.3	125	139.7	129	127/140	5"	138.43	135.47	11	2.31
6"	168.3	150	168.3	154	152/165	6"	163.83	160.87	11	2.31
8"	219.1	200	219.1	204						
10"	273.1	250	273.0	254						
12"	323.9	300	323.9	304						
14"	355.6	350	355.6	354						
16"	406.4	400	406.4							
18"	457.0	450	457.2							
20"	508.0	500	508.0							

DN	NPT ^a		
	Ø EXTÉRIEUR EXTERIOR	NOMBRE FILET AU POUCE NUMBER OF THREADS PER INCH	
en pouce	en pouce	en mm	
1/8"	0.405"	10,29	27
1/4"	0.540"	13,72	18
3/8"	0.675"	17,15	18
1/2"	0.840"	21,34	14
3/4"	1.050"	26,67	14
1"	1.315"	33,40	11½
1 1/4"	1.660"	42,16	11½
1 1/2"	1.900"	48,26	11½
2"	2.375"	60,33	11½
2 1/2"	2.875"	73,03	8
3"	3.500"	88,90	8
3 1/2"	4.000"	101,60	8
4"	4.500"	114,30	8
5"	5.563"	141,30	8
6"	6.625"	168,28	8
8"	8.625"	219,08	8
10"	10.750"	273,05	8
12"	12.750"	323,85	8
14"	14.000"	355,60	8
16"	16.000"	406,40	8
18"	18.000"	457,20	8
20"	20.000"	508,00	8



DIRECTIVE CE PRESSION 2014/68/UE - COMPRENDRE LA PED

PRESSURE EQUIPMENT DIRECTIVE 2014/68/EU - UNDERSTANDING THE PED

AVANT-PROPOS

Dans le cas où un fabricant désire mettre sur le marché de l'Union Européenne des appareils de robinetterie, le fabricant ou à défaut son mandataire doit en évaluer la conformité vis-à-vis de la directive européenne « Équipements sous Pression » N°2014/68/UE (PED).

QU'EST-CE QUE LA DIRECTIVE PED « 2014/68/UE » ?

« DIRECTIVE 2014/68/UE DU PARLEMENT EUROPÉEN ET DU CONSEIL du 15 mai 2014 relative à l'harmonisation des législations des États membres concernant la mise à disposition sur le marché des équipements sous pression »

Elle couvre le risque Pression.

Elle s'applique à la conception, à la fabrication des équipements sous pression.
Récipients, tuyauteries, accessoires de sécurité et accessoires sous pression.

Elle est applicable depuis le 19 juillet 2016.
Elle a été transposée en droit français par le décret n°2015-799 du 01/07/2015.
Elle remplace l'ancienne directive pression 97/23/CE (1997).

L'objectif est d'assurer la libre circulation des équipements marqués CE au sein de l'UE, en assurant le même niveau de sécurité et en supprimant les entraves techniques aux échanges.

EQUIPEMENTS SOUMIS (Neufs ou d'occasion)

- Tuyauteries
- Accessoires sous pression (Robinets, Vannes, Clapets, Manomètres, Joints d'expansion...)
- Accessoires de sécurité (Soupapes, Disques de rupture...)
- Ensembles (Assemblages d'équipements sous pression en vue de constituer un tout intégré et fonctionnel : climatiseurs, chaudières, ...)
- Equipements soumis à l'action de la flamme ou chauffés d'une autre façon présentant un risque de surchauffe prévus pour la production de vapeur ou d'eau surchauffée à une $T^{\circ} > 110^{\circ}\text{C}$.
- Récipients (Cuves, extincteurs, bouteilles appareil respiratoire...)

PREFACE

When a manufacturer wants to put valve equipment onto the European Union market, the manufacturer, or by default its agent, must evaluate the equipment's conformity to the European Pressure Equipment Directive N°2014/68/EU (PED).

WHAT IS THE DIRECTIVE PED 2014/68/EU?

"Directive 2014/68/EU of the European Parliament and of the Council of 15 May 2014 on the harmonisation of the laws of the Member States relating to the making available on the market of pressure equipment"

It covers the risk due to pressure.

*It applies to the design, manufacturing of pressure equipment.
Vessels, piping, security and pressure accessories.*

*It has been applicable since 19 July 2016.
The directive was transposed into French law by the decree n°2015-799 of 01/07/2015, replacing the old Pressure Directive 97/23/CE (1997).*

The objective is to assure the free circulation of equipment marked CE in the European Union, ensuring the same level of security and eliminating technical obstacles during exchanges.

SUBJECTED EQUIPMENT (NEW OR USED)

- Piping
- Accessories under pressure (Valves, check valves, manometers, expansion joints, etc.)
- Security equipment (safety valves, burst disc, etc.)
- Assemblies (Pressure equipment assembly constituting an integrated and functional whole: air conditioners, heaters, etc.)
- Equipment subject to flames or heat presenting a risk of overheating intended for the production of superheated water vapor $T^{\circ} > 110^{\circ}\text{C}$.
- Vessels (tanks, extinguishers, respiratory equipment bottles, etc.)

DIRECTIVE CE 2014/34/UE - COMPRENDRE L'ATEX

DIRECTIVE 2014/34/EU - UNDERSTANDING ATEX



AVANT-PROPOS

Toute société qui fabrique, utilise ou distribue des appareils pouvant être mis en service dans des atmosphères explosives au sein de l'Union Européenne, doivent répondre aux exigences essentielles en matière de santé et de sécurité décrits par les directives ATEX.

QU'EST-CE QU'UNE ZONE ATEX ?

- ATEX est la contraction de ATmosphère EXplosible.
- Une zone ATEX est une zone explosible.

Définition «atmosphère explosible» selon la norme EN 50014 :

Une atmosphère explosible est un mélange avec l'air, dans les conditions atmosphériques, de substances inflammables sous forme de gaz, vapeurs, brouillard ou brumes dans des proportions telles qu'une température excessive ou des étincelles produisent son explosion.

Oxygène + Combustible* + Source d'inflammation =
Oxygen + Combustible + Ignition source*

**Gaz, Vapeurs, Poussières Inflammables / *Flammable gas, vapor, dust*



ATEX : DEUX DIRECTIVES ?

Pour les employeurs : Directive Européenne 1999/92/CE

Elle concerne la protection des travailleurs exposés aux atmosphères explosibles.

Pour les constructeurs : Directive Européenne 2014/34/UE

Elle concerne la conception, la fabrication et l'utilisation des appareils destinés à être utilisés en atmosphères explosibles (électriques, mécaniques, hydrauliques ou pneumatiques).

Depuis le 20/04/2016, la directive N° 2014/34/UE remplace la directive N° 94/9/CE.

Classification des zones ATEX (Zonage)

La directive 2014/34/UE définit les zones à risques d'explosion, avec une distinction entre les atmosphères Gaz (G) et les atmosphères Poussières (D).

PREFACE

Any company that manufactures, uses or distributes equipment used in potentially explosive atmospheres in the European Union must follow the essential requirements in terms of health and safety decreed in the ATEX Directives.

WHAT IS AN ATEX ZONE?

- *ATEX is a contraction of the words ATmosphere EXplosive.*
- *An ATEX zone is a potentially explosive area*

The definition of a Potentially Explosive Atmosphere according to the EN 50014 standard:

A potentially explosive atmosphere is a mixture of air gases, vapors, mists, or dusts combined in a way that can ignite under certain operating conditions.

ATEX: WHY TWO DIRECTIVES?

For employers: European Directive 1999/92/CE

Which concerns the protection of workers exposed to potentially explosive atmospheres.

For manufacturers: European Directive 2014/34/EU

Which concerns the design, fabrication and use of equipment destined for use in potentially explosive atmospheres (electric, mechanical, hydraulic, or pneumatic).

On 20/04/2016, the directive N° 2014/34/EU replaced the directive N° 94/9/CE.

Atex Zone Classification (Zoning)

The directive 2014/34/EU defines explosion risk zones, with a distinction between Gas (G) and Dust (D) atmospheres.

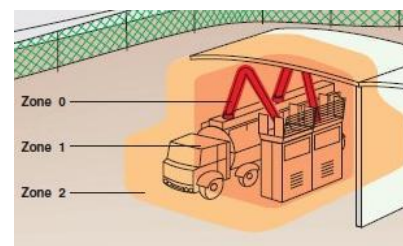

Rapprochez-vous de votre organisme de sécurité et de contrôle pour définir les zones ATEX dans votre usine.
Contact your security and inspection organization to define your plant's ATEX zones.

ZONES DÉFINIES PAR LA RÉGLEMENTATION / REGULATION ZONES

Atmosphère explosive <i>Explosive Atmosphere</i>	Zone gaz / vapeur <i>Gas/Vapor</i>	Zone poussière <i>Combustible Dust</i>
Permanente, en fonctionnement normal/ <i>Present Continuously</i>	0	20
Occasionnelle, en fonctionnement normal/ <i>Present Intermittently</i>	1	21
Accidentelle, en cas de dysfonctionnement/ <i>Present Abnormally</i>	2	22



INDICE DE PROTECTION DES MOTEURS (IP) MOTOR INGRESS PROTECTION RATINGS (IP)

Tous les moteurs électriques ont un indice de protection (IP) à deux chiffres. Cet indice permet de connaître la limite de protection physique du moteur. En effet, un moteur tournant à l'air libre et devant être refroidi par air, n'aura pas le même IP qu'un moteur fonctionnant hermétiquement en atmosphère saline par exemple. Cela ne signifie pas, par contre, qu'il sera moins performant. Il faut juste bien comprendre que 2 moteurs apparemment identiques à première vue peuvent avoir des IP différents, donc des prix différents.

All electric motors have a 2-number protection rating (IP). This rating indicates the limit of physical protection of the motor. For example, a motor running in open-air and cooled by the air will not have the same IP rating as a hermetically-sealed motor running in a salty environment. This however does not mean that one is less effective than the other. Simply it should be understood that two seemingly identical motors could have different IP ratings, therefore two different prices.

Le 1^{er} chiffre indique l'indice de protection (IP) contre les corps solides

The first number indicates the protection rating (IP) against solid particles

CHIFFRE/ NUMBER	SIGNIFICATION MEANING
0	Aucune protection contre l'entrée éventuelle de corps solides / No protection against solid particles
1	Protection contre la pénétration de corps d'un diamètre inférieur à 50 mm / Protection against solid particles smaller than 50mm
2	Protection contre la pénétration de corps d'un diamètre inférieur à 12 mm / Protection against solid particles smaller than 12mm
3	Protection contre la pénétration de corps d'un diamètre inférieur à 2,5 mm / Protection against solid particles smaller than 2.5 mm
4	Protection contre la pénétration de corps d'un diamètre inférieur à 1 mm / Protection against solid particles smaller than 1 mm
5	Protection totale mais la pénétration de fines poussières (de l'ordre du micron) n'est pas totalement assurée / Total protection, but protection against fine dust (micron size range) not completely assured
6	Moteurs étanches immergés / Motors dust-tight

Le 2^{ème} chiffre indique l'indice de protection (IP) contre la pénétration de l'eau

The second number indicates the protection rating (IP) against water

CHIFFRE NUMBER	SIGNIFICATION MEANING
0	Aucune protection / No protection
1	Gouttes d'eau tombant à la verticale sans effet néfaste / Dripping water (vertically falling drops) has no harmful effect
2	Gouttes d'eau tombant avec un angle de 15° sans effet néfaste / Dripping water has no harmful effect when device is mounted at a 15° angle from its normal position.
3	Pluie tombant avec un angle inférieur de 60° sans effet néfaste / Dripping water has no harmful effect when device is mounted at a 15° angle from its normal position.
4	Eau projetée dans toutes les directions sans effet néfaste / Water splashing from any direction has no harmful effect.
5	Eau projetée dans toutes les directions à la lance sans effet néfaste / Water projected by a nozzle has no harmful effect.
6	Jets puissants ou eau de mer sans effet nuisible / Water projected in powerful jets has no harmful effect.
7/8	Immersion sous conditions de durée et de pression sans effet nuisible (8 : données constructeurs) / Immersion subject to duration and pressure conditions has no harmful effect. (8: conditions specified by manufacturer)

VOUS VOULEZ MOTORISER UNE VANNE EXISTANTE ? WOULD YOU LIKE TO MOTORIZE A VALVE?

Remplissez ce formulaire et retournez-le par mail à sales@tecofi.fr
Fill out this form and send it us at sales@tecofi.fr

Etude de faisabilité pour motorisation de vanne en service *Feasibility test for motorization of valves already in operation*

**La vanne comporte-t-elle une embase ISO de motorisation ?
(4 trous percés sur un cercle)**
Does the valve have an ISO plate? (Four holes drilled in a circle)

OUI
YES

Renseignez les points suivants
Fill out the below fields

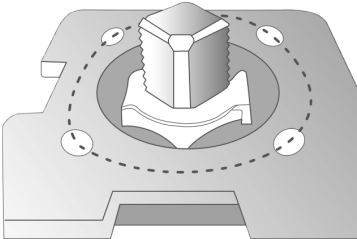

NON
NO

La motorisation est trop aléatoire
Prenez contact avec notre service technique pour obtenir des informations.
Motorization is too hazardous
Contact our sales team for more informations

QUEL COUPLE DE MANŒUVRE ? / What torque to maneuver?

Non connu / *unknown*
Se rapprocher de nos services please, contact our services

Connu / *Known*
avec coefficient de sécurité :
With security coefficient
sans coefficient de sécurité :
Without security coefficient

Type de vanne :

DN :

Type d'étanchéité (métal/métal, élastomère, plastique...) :
Type of sealing (metal/metal, elastomer, plastic, etc)

Nature du fluide :
Nature of fluid

Pression d'utilisation max :
Maximum working pressure

Température du fluide :
Temperature of fluid

Marque :
Brand

Référence :
Reference number

L'EMBASE Norme ISO / Baseplate ISO Standard

La distance D entre deux perçages opposés est de (mm) :
The distance D between 2 opposite holes is (mm):

<input type="checkbox"/>	36	F03
<input type="checkbox"/>	42	F04
<input type="checkbox"/>	50	F05
<input type="checkbox"/>	70	F07
<input type="checkbox"/>	102	F10
<input type="checkbox"/>	125	F12
<input type="checkbox"/>	140	F14
<input type="checkbox"/>	165	F16

Quels types de trous ? / *What type of holes?*

Lisses / *Smooth* Taraudés / *Threaded*

TYPE D'ACTIONNEUR SOUHAITÉ / Actuator Type Needed

Alimentation électrique dont vous disposez :
The power supply you have

Si ATEX, quelle classe de protection :
ATEX, protection class

ACTIONNEUR PNEUMATIQUE <i>PNEUMATIC ACTUATOR</i>	ACTIONNEUR ÉLECTRIQUE <i>ELECTRIC ACTUATOR</i>
<p><input type="checkbox"/> Double effet <i>double Acting</i></p> <p><input type="checkbox"/> Simple effet <i>single Acting</i></p> <p><input type="checkbox"/> Position NO <i>Opened position</i></p> <p><input type="checkbox"/> Position NF* <i>Closed position</i></p> <p><small>* Une vanne à papillon doit être montée ouverte / <i>A butterfly valve must be mounted open</i></small></p> <p><input type="checkbox"/> Électro-distributeur <i>Solenoid Valve</i></p> <p>Tension : <i>Voltage</i></p> <p><input type="checkbox"/> Contacts fin de course <i>Limit Switches</i></p> <p><input type="checkbox"/> mécaniques <i>mechanical</i></p> <p><input type="checkbox"/> inductifs <i>inductive</i></p> <p><input type="checkbox"/> Commande manuelle de secours <i>Manual emergency control</i></p> <p>Pression air comprimé : <i>Compressed air pressure</i></p>	<p>Actionneur : <input type="checkbox"/> ON/OFF <i>On/Off</i> Ou <input type="checkbox"/> Multitour <i>Multiturn</i></p> <p>Positionnement / <i>Positioning</i> :</p> <p>Régulation / <i>Modulating</i> :</p> <p>Tension / <i>Voltage</i> :</p> <p>Temps de manœuvre / <i>Operating time</i> :</p> <p><input type="checkbox"/> Contacts fin de course <i>Limit Switches</i></p> <p><input type="checkbox"/> Commande manuelle de secours <i>Manual emergency control</i></p> <p><input type="checkbox"/> Résistance de chauffage <i>Heating resistor</i></p> <p><input type="checkbox"/> Limiteur de couple <i>Torque limiter</i></p>



L'AXE / Stem

VANNES 1/4 DE TOUR

1/4 TURN VALVES

Carré ou méplat
Square or flat

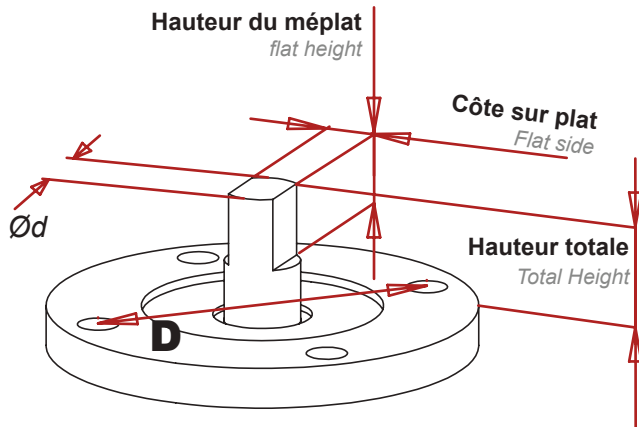

Clavette
Key

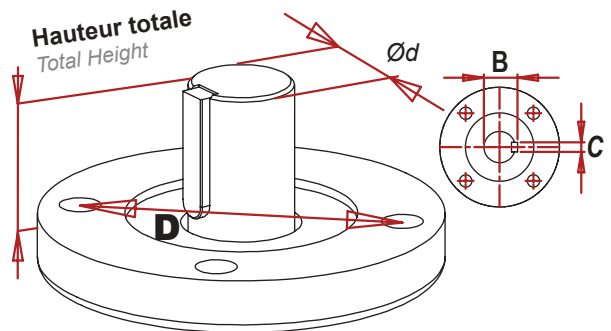

Carré dans l'axe de la tuyauterie
Squared parallel to the axis of the stem

Carré hors axe de la tuyauterie
Squared perpendicular to the axis of the stem

Méplat
flat

Côte sur plat / Flat side : mm

Hauteur du méplat / Flat height : mm

Hauteur totale / Total Height : mm

Ø axe d / Ø stem d : mm

Dimension de la clavette C : mm
Key dimensions C

Côte sur plat B : mm
Flat side

Hauteur totale / Total Height : mm

Ø axe d / Ø stem d : mm

Monté sur réducteur / Mounted on gearbox

VANNES MULTITOUR

MULTI-TURN VALVES

Clavette
Key

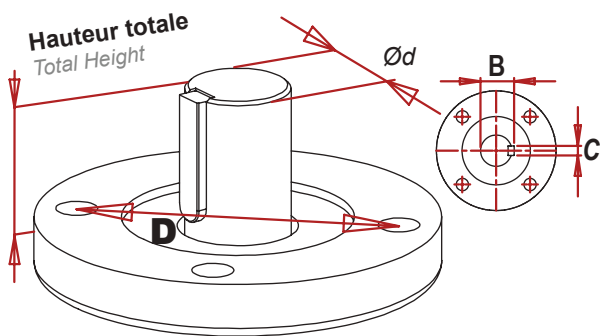

Tige montante
Rising stem

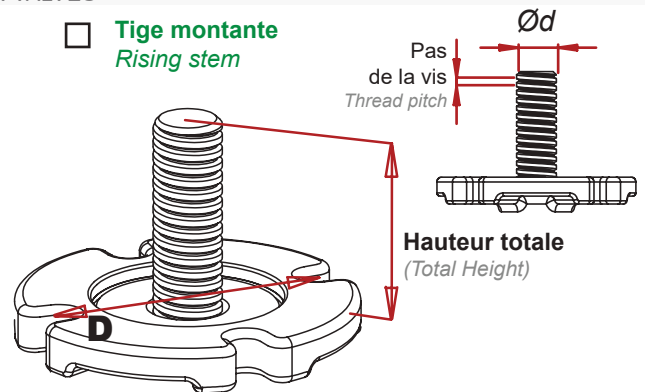

Nombre de tours pour manœuvre complète :
Number of turns to fully open/close

.....

Dimension de la clavette C : mm
Key dimensions C

Côte sur plat B : mm
Flat side

Hauteur totale / Total Height : mm

Ø axe d / Ø stem d : mm

Monté sur réducteur / Mounted on gearbox

Nombre de tours pour manœuvre complète :
Number of turns to fully open/close

.....

Pas de la vis / Thread pitch : mm

Pas à gauche / Left-hand pitch Pas à droite / Right-hand pitch

Nombre de filets / Number of threads :

Hauteur totale vanne ouverte : mm
Total height with valve open

Hauteur totale vanne fermée : mm
Total height with valve closed

Ø axe d / Ø stem d : mm

GÉNÉRALITÉS

GENERAL INSTRUCTIONS

Nettoyer les tuyauteries

- Avant les essais et le démarrage des installations, procéder au rinçage abondant des tuyauteries (eau, air, vapeur selon compatibilité).
- Il est indispensable d'éliminer toutes particules et objets divers dans les tuyauteries et particulièrement les «gratons» de soudures qui endommagent irrémédiablement les portées d'étanchéité de la robinetterie.

Nettoyer les portées de joint

- Avant le montage, veiller à ce que les portées de joint soient parfaitement propres, exemptes de rayures préjudiciables à une bonne étanchéité.

Aligner les tuyauteries

- Vérifier l'alignement des tuyauteries.
- Ne pas compter sur la robinetterie pour récupérer un mauvais alignement de la tuyauterie : risque de création de fuites, de défaut de manoeuvre ou même de rupture.

Éviter les «coups de bélier»

- Un coup de bélier peut générer une montée en pression d'une extrême brutalité.
- Les dommages causés par un coup de bélier peuvent être considérables ; organe d'obturation de vanne fendu, axes déformés, appareils divers détruits...
- Les causes des coups de bélier sont très variées : le démarrage de la pompe et la fermeture brutale de vanne sont les plus fréquentes.

Manutentionner la robinetterie avec précaution

- Elinguer les robinets par le corps.
- Ne pas s'accrocher au volant ou au servo-moteur.
- Attention aux chocs.

Respecter le sens de montage

- Certains appareils de robinetterie sont unidirectionnels (clapets de non-retour, vannes à guillotine, etc).
- Veiller à un montage conforme au sens de la flèche ou aux instructions de montage.

Supporter les vannes

- Dans certains cas (vannes de grande longueur, servo-moteur lourd), il peut être indispensable de prévoir des supports qui éviteront des tensions préjudiciables à la manoeuvre risquant la détérioration rapide des vis de manoeuvre et des portées d'étanchéité.

Clean the pipes

- Before tests and installation, thoroughly rinse the piping (using water, air, or steam according to the cleaning procedures for the pipe).
- It is essential to eliminate all the particles and various objects in the pipes, particularly welding residue which could definitively damage the valve seat.

Clean the gasket seat

- Before assembly, take care that the gasket seats are perfectly clean, and free of scratches that could affect good sealing.

Align piping

- Check piping alignment.
- Do not rely on the valves to correct bad alignment: risk of leaks, operatig defects or even breaking.

To avoid « water hammers »

- A water hammer can generate a rise in pressure of extreme brutality.
- The damage caused by a water hammer is considerable: split obturators, deformed axes, other damaged apparatuses, etc.
- The cause of water hammers varies, but generally they are caused by starting a pump or suddenly closing a valve.

Handle the valves with precaution

- Sling valves by the body.
- Do not hang valves by the handwheel or the servomotor.
- Pay attention to shocks.

Respect assembly flow direction

- Some valves are one-way (non-return valve, knife gate valves, etc).
- Ensure assembly follows the arrow directions and/or the assembly instructions.

Support the valves

- In certain cases, valves of large length, with heavy servo-motors, it is essential to provide supports which will prevent unwanted strain that while operating the valve will cause a fast deterioration of the stem and the seal tightness.



GÉNÉRALITÉS

GENERAL INSTRUCTIONS

Respecter les couples de serrage

- Il est préjudiciable d'appliquer des couples de serrage supérieurs au besoin d'étanchéité.
- Ceci peut entraîner des marquages de portées d'étanchéité et des usures prématurées, particulièrement pour les portées élastomère (robinets à membrane).

Souder les robinets ouverts

- Lors de la soudure des robinets en acier ou en inox, veiller à ce qu'ils soient en position ouverte.

Déplacer avec précaution la robinetterie

- Veiller au maintien des revêtements et des protections.
- Éviter les chocs et les frottements qui, en détruisant les revêtements, créent des amorces de corrosion.

Stocker les équipements dans de bonnes conditions

- Les appareils de robinetterie doivent être stockés à l'abri :
 - . de l'humidité et de la pluie pour éviter la corrosion ;
 - . du vent, du sable pour éviter la pénétration de sable ou de particules solides dont la présence est catastrophique pour les portées d'étanchéité et de guidage ;
 - . du soleil et de la chaleur : ils abiment les revêtements ; ils sont particulièrement néfastes pour la robinetterie plastique sensible aux ultra-violets.
- Les appareils de robinetterie à portage élastomère doivent toujours être stockés «entrouverts».
- Les appareils à portée métallique doivent être stockés fermés (sauf spécification particulière) pour éviter la pénétration des particules dans les cavités internes.
- Les robinets à boisseau sphérique doivent être stockés en position «ouverte»
- Conserver les appareils de robinetterie avec leurs bouchons plastiques, ne pas oublier naturellement de les enlever au montage.

Respect tightening torques

- Applying a higher tightening torque than necessary is detrimental to the valve
- This can create markings on the seats and premature wear, particularly for rubber seats (diaphragm valves).

Weld valves opened

- Ensure the valve is opened when welding steel or stainless steel valves.

Handle valves with precaution

- Take care of the coatings and protections.
- Avoid shocks and friction that will destroy the coatings and expose the valve material to corrosion.

Store the equipment in proper conditions

- The valves must be stored protected from:
 - . humidity and rain to avoid corrosion;
 - . wind, sand: to avoid solid particles from entering the valve, which could severely affect the seal tightness;
 - . Sunlight and heat: they damage coatings and are particularly harmful to plastic valves and fittings that are sensitive to ultraviolet light.
- Valves with rubber seat must always be stored half-opened.
- Equipment with metal seats must be stored closed (except particular specifications) to prevent particles from entering the equipment.
- Ball valves must be stored in open position.
- Store equipment with their plastic caps and remove them when mounting the valves.

EXTRAIT DES CONDITIONS GENERALES DE VENTE TECOFI

1. OBJET :

1.1. Les (...) CGV (...) sont applicables pour tous les produits (ci-après, désignés les « Produits ») fournis par la société TECOFI (ci-après dénommée « TECOFI ») auprès de l'ensemble de sa clientèle (ci-après dénommée le/les « Client(s) »). Le présent document ne constitue qu'un extrait des CGV applicables. Le Client ne pourra en aucun cas se prévaloir de cet extrait pour s'opposer à l'application des clauses prévues dans la version complète des CGV non reproduites dans l'extrait.

1.2. (...) Les CGV littéraires sont également consultables sur le site internet de TECOFI (www.tecofi.fr). Toute commande (ci-après la/les « Commande(s) »), quelle qu'en soit l'origine, implique l'adhésion sans réserve aux CGV, qui annulent toute clause contraire pouvant figurer dans les documents types établis unilatéralement par le Client (...) sauf accord dérogatoire exprès et préalable de TECOFI. (...)

2. COMMANDE :

2.1. Tout bon de Commande du Client (ci-après, le « Bon de commande ») doit parvenir à TECOFI par courrier, télécopie, EDI ou e-mail, et préciser la quantité exacte et les références précises des Produits commandés ainsi que les délais de livraison souhaités. Les Commandes ne deviennent définitives qu'après acceptation écrite de TECOFI du Bon de commande, qui se matérialise par l'émission par TECOFI, sous quelque forme écrite que ce soit y compris par voie électronique, d'un accusé de réception de la Commande. (...) Seul le tarif en vigueur au jour de l'acceptation de la Commande par TECOFI sera applicable.

2.2. TECOFI se réserve le droit de refuser les Commandes (...).

2.3. Pour toute commande mise à disposition dans les locaux de TECOFI ou livrée en France métropolitaine, le minimum de Commande est de 150 euros HT. En-deçà de ce seuil, des frais administratifs d'un montant de 30 euros HT seront automatiquement facturés en plus au Client. Pour toute Commande livrée hors du territoire de la France métropolitaine, le minimum de Commande est de 230 euros HT. En-deçà de ce seuil, des frais administratifs d'un montant de 50 euros HT seront automatiquement facturés en plus au Client.

2.4. TECOFI fabrique et/ou distribue également des Produits qui ne figurent pas sur son catalogue de Produits standards. Ainsi, le Client (...) est invité à transmettre à TECOFI, une expression de besoins. Sur la base de cette expression de besoins, TECOFI établira une offre de prix (ci-après, l'« Offre de prix ») spécifique. L'acceptation de l'Offre de prix par le Client supposera la transmission par ce dernier, y compris par voie électronique, d'un accord écrit en tout point conforme à l'Offre de prix émise par TECOFI. (...) L'Offre de prix est valable pendant un délai de trente (30) jours, seule la date de réception de l'accord du Client par TECOFI faisant foi. (...)

2.6. Le Client est seul responsable de l'expression de ses besoins qu'il doit spontanément formuler auprès de TECOFI et ne saurait en conséquence nullement engager la responsabilité de TECOFI en cas de mauvaise expression de besoins, ce que ce dernier reconnaît et accepte expressément. (...)

3. TARIFS :

3.1. Produits standards

3.1.1. S'agissant des Produits standards présents sur le catalogue TECOFI, le tarif est fixé dans les conditions tarifaires applicables au jour de l'acceptation de la Commande (...).

3.1.2. Les tarifs s'entendent hors taxes, hors frais de dossiers techniques et de certificats, d'emballage, de transport et d'assurance. (...).

3.2. Produits spécifiques (...)

3.2.2. L'Offre de prix s'entend hors taxes, hors frais de dossiers techniques et de certificats, d'emballage, de transport et d'assurance. (...)

4. CONDITIONS DE PAIEMENT :

4.1. Les factures émises par TECOFI sont payables dans un délai de trente (30) jours suivant la date d'émission de la facture (...) Aucun escompte pour paiement anticipé n'est accordé par TECOFI à ses Clients.

4.2. Tout retard de paiement entraîne, de plein droit (...) l'application d'une indemnité forfaitaire pour frais de recouvrement de quarante euros (40 €) et des pénalités de retard égales au taux d'intérêt appliqué par la Banque centrale européenne à son opération de refinancement la plus récente majorée de 10 points de pourcentage, sans préjudice de la faculté pour TECOFI de réclamer une indemnisation complémentaire sur justificatif.

4.3. Dans l'hypothèse d'une première Commande adressée par le Client, d'un retard de paiement ou d'impayés, d'une détérioration du crédit du Client (...), de l'obtention par TECOFI de renseignements financiers insuffisants (...), d'une réduction de l'encours maximum accordé (...), TECOFI se réserve le droit : de refuser une Commande du Client ou de suspendre l'exécution des Commandes en cours ; de diminuer le plafond de l'encours consenti au Client ; de réduire les délais de paiement octroyés ou d'exiger un paiement comptant ou un paiement anticipé avant la livraison ; d'exiger l'octroi de toutes garanties de paiement spécifiques que TECOFI jugera nécessaires. A défaut de pouvoir obtenir de telles garanties, pour quelque cause que ce soit, TECOFI se réserve le droit de ne pas honorer les Bons de commandes et/ou de résilier les Commandes en cours. (...)

5. DELAI DE MISE A DISPOSITION, EMBALLAGE, TRANSFERT DES RISQUES, TRANSPORT, RETARDS

Sauf stipulation expresse, écrite et préalable convenue entre les parties, les Produits sont mis à disposition du Client dans les entrepôts ou usines de TECOFI.

5.1. Délai de mise à disposition

5.1.1. (...) Les délais de mise à disposition convenus entre les parties dans le cadre de la Commande ou d'un contrat ne sont donnés qu'à titre indicatif et ne sauraient en aucun cas être considérés comme étant fermes et définitifs. En cas de prise en charge du transport par TECOFI, les délais de livraison qui correspondent aux délais nécessaires pour transporter les Produits des usines de TECOFI dans les entrepôts du Client, s'appliquent en sus du délai de mise à disposition convenue entre les parties. (...)

5.2. Emballage

(...) Les frais d'emballage sont toujours à la charge du Client et s'appliquent en sus du tarif ou de l'Offre de prix. (...)

5.3. Transfert des risques

Sans préjudice des stipulations des contrats types de transports, la livraison et le transfert des risques s'opèrent entre les parties au moment de la mise à disposition des Produits, dans les usines ou entrepôts de TECOFI, avant chargement, le chargement intervenant sous la responsabilité exclusive du Client. Sans préjudice des stipulations des contrats types de transports, dans l'hypothèse d'une prise en charge du transport par TECOFI convenue entre les parties et sous réserve de l'application d'un incoterm spécifique, la livraison et le transfert des risques liés aux Produits s'opèrent au moment de la première présentation du transporteur au lieu de livraison convenue, le déchargement des Produits intervenant sous la responsabilité exclusive du Client.

5.4. Retard de livraison ou mise à disposition

5.4.1. Aucun retard dans la mise à disposition des Produits n'autorise le Client à annuler, totalement ou partiellement, sa Commande ou à refuser la réception des Produits. (...)

5.4.3. Aucune pénalité ne saurait être appliquée de manière unilatérale et non contradictoire par le Client, toute compensation avec une somme due par le Client à TECOFI supposant, en outre, que TECOFI ait expressément reconnu, par écrit et préalablement, la réalité du grief justifiant l'application des pénalités. En tout état de cause, l'application de pénalités ne saurait revêtir un caractère purement forfaitaire et prédéterminé. (...)

5.4.4. En cas de refus des Produits lors de la livraison des Produits ou en cas de refus d'enlèvement des Produits mis à disposition, TECOFI se réserve le droit de facturer des frais de stockage au Client, ce dernier supportant également les risques liés aux Produits à compter de la constatation de ce refus (...).

5.5. Réserves aux transporteurs

En cas d'avaries, pertes, retards, manquants, il appartient au Client de consigner les protestations et réserves régulières auprès du transporteur (...) conformément aux dispositions de l'article L. 133-3 du Code de commerce, et ce, sans préjudice du respect de toute autre disposition légale, réglementaire ou conventionnelle applicable. Un double doit être adressé à TECOFI (...)

6. RECEPTION ET CONFORMITE :

6.1. (...) toutes réclamations relatives à la conformité du Produit ou aux défauts apparents doivent être portées à la connaissance de TECOFI, à peine d'irrecevabilité, par écrit, dans un délai de trois (3) jours à compter de la mise à disposition des Produits ou, en cas de prise en charge du transport par TECOFI, à compter de la livraison des Produits au lieu convenu. Pour être valable, toute réclamation doit mentionner obligatoirement les références des Produits ainsi que le numéro et la date de la Commande concernée. (...)

6.2. Les retours de Produits non-conformes ne sont autorisés et acceptés qu'après accord préalable et écrit de TECOFI. Les Produits doivent être retournés à TECOFI par le Client, sans avoir subi de quelconques modifications dans leur emballage d'origine, dans un délai de trois (3) jours à compter de la reconnaissance par TECOFI de la non-conformité. La responsabilité de TECOFI est strictement limitée au remplacement des Produits non-conformes ou au remboursement des Produits litigieux, à leur prix de facturation, à l'exclusion de tous dommages-intérêts.

6.3. (...) Aucun retour ni reprise ne sera ainsi accepté par TECOFI en cas de mauvaise expression par le Client de ses besoins ou d'erreur d'appréciation par ce dernier des contraintes pouvant peser quant à l'installation et/ou l'intégration des Produits dans un autre équipement. Il appartient ainsi au Client de vérifier l'adéquation entre le Produit et les conditions effectives d'utilisation. (...) En outre, aucun retour ni reprise ne pourra avoir lieu, en raison d'une non-conformité des Produits, dès lors que le Produit livré aura été installé, mis en service, intégré à un autre équipement, etc. (...)

7. INSTALLATION - MISE EN SERVICE :

Les opérations d'installation et de mise en place sont réalisées par le Client, sous sa seule et entière responsabilité, et doivent être effectuées selon les règles de l'art et les prescriptions transmises par TECOFI.

(...) le Client ne saurait prétendre en aucun cas à une quelconque garantie sur les Produits en cas d'installation ou de mise en service des Produits qui n'aurait pas été effectuées dans les règles de l'art ou selon les prescriptions transmises par TECOFI ou pour toute utilisation du Produit non conforme. (...)

8. GARANTIE – RESPONSABILITE – RETRAIT & RAPPEL – PIECES DETACHEES :

8.1. Garantie

8.1.1. TECOFI garantit les Produits pendant douze (12) mois à compter de leur mise à disposition, contre tout défaut non apparent au moment de la mise à disposition ou de la livraison des Produits (...)

8.1.2. En cas de survenance d'un vice caché, le Client est tenu de notifier par écrit à TECOFI, sans délai et au plus tard dans les soixante douze (72) heures ouvrables, la découverte de celui-ci en mentionnant obligatoirement les références des Produits ainsi que le numéro et la date de la Commande concernée. (...) En cas de vice caché imputable au Produit reconnu par les deux

parties, TECOFI s'engage à réparer le Produit défectueux ou à remplacer le Produit défectueux, à l'exclusion de tout autre remède. (...) Sous réserve de l'application de dispositions d'ordre public, TECOFI ne pourra nullement être tenue au paiement d'une quelconque somme à titre de dommages-intérêts en cas de survenance d'un vice caché rendant impropre le Produit à l'usage auquel il est destiné. En tout état de cause, TECOFI ne pourra en aucun cas être tenue d'effectuer à ses frais le démontage du Produit défectueux ni le montage du Produit de remplacement dans les équipements du Client.

8.1.3. La garantie ne s'applique pas, de plein droit : aux éléments qui, par la nature de leurs matériaux ou de leur fonction, subissent une usure naturelle ; aux cas de détérioration ou d'accident qui proviendraient d'une modification ou d'une intervention du Client ou d'un tiers sur le Produit, du non-respect par le Client des notices d'installation, d'utilisation ou de maintenance, d'un défaut de surveillance, de stockage ou d'entretien, de la négligence du Client, d'une installation ou d'une utilisation non conforme aux règles de l'art ou ne respectant pas les caractéristiques techniques du Produit et notamment la température de service maximale et/ou la pression de service maximale, ou détournée de son objet habituel ou en cas de survenance d'un coup de bélier ou de cavitation ou de vitesse excessive des fluides ou de non-respect des distances de sécurité d'usage ; en cas de non-paiement, total ou partiel, par le Client.

8.2. Responsabilité

8.2.1. La responsabilité de TECOFI ne saurait être engagée par le Client que sous réserve que ce dernier établisse une faute imputable à TECOFI, un préjudice et un lien de causalité entre la faute et le préjudice. En tout état de cause, TECOFI ne peut accepter que la prise en charge de l'indemnisation d'un préjudice prévisible, certain, direct, matériel et corporel - à l'exclusion de tout préjudice imprévisible, indirect, immatériel, incorporel ou hypothétique - présentant un lien de causalité suffisant avec un manquement de TECOFI à ses obligations. (...)

8.2.2. La responsabilité de TECOFI ne pourra en aucun cas être engagée, sans que la liste ci-après soit limitative : en cas de non-conformité des Produits aux normes et réglementations qui entreraient en vigueur après l'acceptation de la Commande, en cas de mauvais entreposage et/ou stockage des Produits, en cas de mauvaise installation, mise en service et/ou manipulation des Produits par le Client, en cas d'utilisation des produits dans des conditions anormales. (...)

8.2.3. Sous réserve de l'application de disposition d'ordre public, toute réclamation que le Client pourrait formuler à l'encontre de TECOFI, quelle qu'en soit la cause et la nature, se prescrit dans le délai d'un (1) an à compter du fait générateur de la réclamation. Passé ce délai et par dérogation expresse aux dispositions de l'article L.110-4 du Code de commerce, toute action que pourrait engager le Client à l'encontre de TECOFI sera prescrite de plein droit. La responsabilité de TECOFI est en tout état de cause plafonnée à une somme égale au montant des commandes adressées par le Client dans les douze (12) mois précédant la date de mise à disposition des Produits litigieux. (...)

9. RESERVE DE PROPRIETE :

TECOFI SE RESERVE LA PROPRIETE DES PRODUITS VENDUS JUSQU'AU COMPLET PAIEMENT DU PRIX. (...) Pendant la durée de la réserve de propriété en tant que dépositaire, les risques ayant été transférés dans les conditions visées à l'article 5 des CGV, le Client devra assurer les Produits contre tous les risques de dommages ou de responsabilités, (...) De convention expresse, les Produits en stock chez le Client sont réputés afférents aux factures non réglées. (...) Le Client est autorisé à revendre ou à transformer les Produits livrés dans l'exécution normale de son commerce. Le cas échéant, le Client s'engage à céder à TECOFI ses créances sur les sous-acquéreurs à concurrence des sommes dues. (...)

10. CONFIDENTIALITE - PROPRIETE INTELLECTUELLE :

10.1. Le Client s'interdit de divulguer, utiliser, transmettre, communiquer, exploiter, directement ou indirectement (...) tout autre document ou toute information remis à l'occasion de la relation entre le Client et TECOFI. Cette obligation perdurera pour cinq (5) ans après la cessation des relations commerciales (...).

10.2. Le Client reconnaît que TECOFI est titulaire de l'ensemble des droits de propriété intellectuelle couvrant les Produits et études fournis au Client et qu'aucun droit d'utilisation ou de reproduction desdits droits ne lui est conféré, sauf convention écrite et préalable. (...)

11. FORCE MAJEURE :

L'exécution par les parties de leurs obligations sera suspendue en cas de survenance d'un événement de force majeure (...) qui en général ou retarderait l'exécution. (...) Sont considérés de plein droit comme constitutifs de cas de force majeure, sans que cette liste soit exhaustive, l'incendie, la grève totale ou partielle, le terrorisme, les guerres, les événements politiques, les blocs, une modification légale ou réglementaire, les catastrophes naturelles, les irrégularités dans les livraisons des matières premières ainsi que toute impossibilité d'approvisionnement. (...)

12. ATTRIBUTION DE JURIDICTION :

Les relations entre TECOFI et le Client sont régies par le droit français, en ce compris les dispositions de la Convention des Nations Unies sur les contrats de vente internationale de marchandises (Vienne 1980).

Tous les litiges qui s'élevaient entre les parties à l'occasion de leurs rapports commerciaux et relatifs notamment au CGV et/ou aux commandes, quels que soient le lieu de livraison, le mode de paiement accepté, et ce même dans le cas d'appel en garantie et/ou de pluralité de défendeurs, seront portés devant les tribunaux compétents du ressort du siège social de Tecofi. (...)

EXTRACT FROM THE GENERAL TERMS OF SALE TECOFI

1. PURPOSE:

1.1. The (...) GTS apply to all products (hereafter referred to as the "Products") supplied by the company TECOFI (hereafter referred to as "TECOFI") to the whole of its clientele (hereafter referred to as the "Customer(s)"). This document is only an extract of the applicable GTS. The Customer may not use this extract, under any circumstances, in order to oppose the application of clauses stipulated in the complete version of the GTS and not reproduced in the extract.

1.2. (...) The literary GTS may also be consulted on TECOFI's website (www.TECOFI.fr). All orders (hereafter the "Order(s)"), of any origin whatsoever, imply unreserved acceptance of the GTS, which cancel any clause to the contrary indicated in any standard documents established unilaterally by the Customer (...), unless specifically and previously otherwise agreed by TECOFI. (...)

2. ORDER:

2.1. All Order Forms from the Customer (hereafter the "Order Form") must be sent to TECOFI by mail, fax, EDI or email, and specify the precise quantity and precise references of the Products ordered, along with the required delivery lead times. Orders are only final after written acceptance from TECOFI of the Order Form, formalised by a confirmation of receipt by TECOFI of the Order, sent in any written format whatsoever, including electronically. (...) Only the price in force on the date of acceptance of the Order by TECOFI will apply.

2.2. TECOFI reserves the right to refuse Orders (...).

2.3. For any order made available in TECOFI's premises or delivered to Metropolitan France, the minimum Order is 150 Euros excluding tax. Below this amount, additional administrative costs of an amount of 30 Euros excluding tax will be automatically invoiced to the Customer. For any Order delivered outside of the territory of Metropolitan France, the minimum Order is 230 Euros excluding tax. Below this amount, additional administrative costs of an amount of 50 Euros excluding tax will be automatically invoiced to the Customer.

2.4. TECOFI also manufactures and/or distributes Products that are not included in its catalogue of standard Products. Thus, a Customer (...) may inform TECOFI of its requirements. On the basis of this indication of requirements, TECOFI will issue a specific price offer (hereafter the "Price Offer"). The Customer's acceptance of the Price Offer will imply that the latter sends, including electronically, written consent on all aspects of the Price Offer issued by TECOFI. (...) The Price Offer will be valid for a period of thirty (30) days; only the date of receipt of the Customer's consent by TECOFI will be used as evidence of this date. (...)

2.6. The Customer is solely responsible for the indication of the requirements that it must put forward, on its own initiative, to TECOFI and may not therefore incur TECOFI's liability in the case of poor indication of the requirements, which the Customer acknowledges and specifically accepts.

3. PRICES:

3.1. Standard Products

3.1.1. As regards the standard Products present in the TECOFI catalogue, the price is set in accordance with the pricing terms and conditions applicable on the date of acceptance of the Order (...)

3.1.2. The prices are tax-exclusive prices, excluding technical file costs and costs of certificates, packaging, transport and insurance (...).

3.2. Specific Products (...)

3.2.2. The Price Offer is tax-exclusive, excluding technical file costs and costs of certificates, packaging, transport and insurance (...).

4. PAYMENT TERMS:

4.1. The invoices issued by TECOFI are payable within a period of thirty (30) days following the date of issue of the invoice (...). No discount for early payment is granted by TECOFI to its Customers.

4.2. Any late payment will entail the application of a fixed indemnity for debt recovery costs, automatically (...), of forty (€40) Euros and late penalties equal to the interest rate applied by the European Central Bank to its most recent refinancing operation, increased by 10 percentage points, without prejudice to the possibility available to TECOFI to claim additional compensation with supporting evidence.

4.3. In the event of a first Order sent by the Customer, late payment or outstanding invoices, a decline in the Customer's credit situation (...), of insufficient financial information made known to TECOFI (...), or a decrease in the maximum outstanding amount granted (...), TECOFI reserves the right: to refuse the Customer's Order or to suspend the performance of Orders in progress; to reduce the upper limit of the outstanding amount granted to the Customer; to reduce the payment terms granted or to request an immediate payment or a payment before delivery; to request all specific payment guarantees that TECOFI will deem necessary. In the event that TECOFI is unable to obtain such guarantees, for any reason whatsoever, TECOFI reserves the right not to respect the Order Forms and/or to terminate the Orders in progress. (...)

5. AVAILABILITY PERIOD, PACKAGING, TRANSFER OF RISKS, TRANSPORT, DELAYS

Unless otherwise specifically stipulated beforehand in writing by the parties, the Products are made available to the Customer in TECOFI's warehouses or factories.

5.1. Availability period

5.1.1. (...) The availability periods agreed between the parties in relation to the Order or an agreement are only given as an

indication and may not, in any event, be considered as firm and final. In the event that the transport is borne by TECOFI, the delivery lead times which correspond to the periods required for carrying the Products from TECOFI's factories to the Customer's warehouses, apply in addition to the availability period agreed by the parties. (...)

5.2. Packaging

(...) Packaging costs are always borne by the Customer and apply in addition to the price or Price Offer. (...)

5.3. Transfer of risks

Without prejudice to the provisions of standard transport agreements, the delivery and transfer of the risks take place between the parties upon availability of the Products, in TECOFI's factories or warehouses, before loading. The loading takes place under the Customer's exclusive liability. Without prejudice to the provisions of standard transport agreements, in the event that the transport is borne by TECOFI as agreed between the parties and subject to the application of a specific incoterm, the delivery and transfer of the risks related to the Products take place upon the first presentation of the haulage carrier at the agreed place of delivery. The unloading of the Products takes place under the Customer's exclusive liability.

5.4. Late delivery or availability

5.4.1. No delay in the availability of the Products will authorise the Customer to cancel its Order in whole or partially, or to refuse receipt of the Products. (...)

5.4.3. No penalty may be applied unilaterally by the Customer without consultation with TECOFI. Moreover, any offsetting against an amount owed by the Customer to TECOFI implies that TECOFI has specifically acknowledged, in writing and beforehand, the reality of the claim justifying the application of the penalties. In any event, the application of penalties may not be purely fixed and predefined. (...)

5.4.4. In the event of refusal of the Products upon delivery of them or in the event of refusal to collect the Products made available, TECOFI reserves the right to invoice storage costs to the Customer, which must also bear the risks related to the Products as from acknowledgment of this refusal.

5.5. Reservations made to the haulage carriers

In the event of damaged goods, loss, delays, missing goods, the Customer is responsible for indicating the protests and regular reservations to the haulage carrier (...), in accordance with article L. 133-3 of the French Commercial Code, without prejudice to respecting any other legal, regulatory or conventional provisions applicable. A copy must be sent to TECOFI. (...)

6. RECEIPT AND COMPLIANCE:

6.1. (...) all claims related to the compliance of the Product or any visible defects must be made known to TECOFI, in order for them to be admissible, in writing, within a period of three (3) days as from the availability of the Products or, in the case of TECOFI bearing the transport, as from delivery of the Products at the agreed place. In order to be valid, all claims must compulsorily indicate the references of the Products and the number and date of the Order in question. (...)

6.2. Returns of non-compliant Products are only authorised and accepted with TECOFI's prior written consent. The Products must be returned to TECOFI by the Customer, without any amendment whatsoever in their original packaging, within a period of three (3) days as from acknowledgement by TECOFI of the lack of compliance. TECOFI's liability is strictly limited to replacing the non-compliant Products or reimbursing the litigious Products, at their billing price, with the exclusion of any damages.

6.3. (...) No return will thus be accepted by TECOFI in the case of poor indication by the Customer of its requirements or the latter's error of judgment of the constraints involved regarding the installation and/or inclusion of the Products in other equipment. The Customer is thus responsible for checking the appropriateness of the Product with the actual conditions of use. (...) Moreover, no return may take place, for lack of compliance of the Products, when the delivered Product has been installed, put into service, included in another equipment, etc. (...)

7. INSTALLATION - SERVICE:

Installation and fitting operations are carried out by the Customer, under the latter's sole and complete responsibility, and must be performed in accordance with the professional methods and the instructions provided by TECOFI.

(...) the Customer may not claim any guarantee whatsoever, under any circumstances, on the Products when they have not been installed or put into service in accordance with professional methods or according to the instructions provided by TECOFI or for any non-compliant use of the Product. (...)

8. WARRANTY – LIABILITY – WITHDRAWAL & RECALL – SPARE PARTS:

8.1. Warranty

8.1.1. TECOFI guarantees the Products for a period of twelve (12) months as from their availability, for any defect that is not visible upon the availability or the delivery of the Products (...).

8.1.2. In the case of a hidden defect, the Customer is required to inform TECOFI in writing, immediately and within seventy-two (72) working hours at the latest, of the discovery of the defect, indicating compulsorily the references of the Products and the number and date of the Order in question. (...) In the event of a hidden defect attributable to the Product and acknowledged by both parties, TECOFI undertakes to repair the faulty Product or to replace it, with the exclusion of any other solution. (...) Subject to the application of public policy rules, TECOFI may not at all be required to pay any amount of damages whatsoever in the case of occurrence of a hidden defect making the Product unfit for its purpose. In any event, TECOFI may not, under any circumstances, be required to dismantle the faulty Product, at its cost, or to assemble the replacement Product in the Customer's equipment.

8.1.3. The warranty does not apply, automatically: to elements which, due to their materials or their purpose, undergo natural wear and tear; to situations of deterioration or accident due to an amendment or intervention by the Customer or a third party on the Product, lack of respect by the Customer of the installation, use or maintenance instructions, faulty surveillance, storage or servicing, Customer's negligence, an installation or use that does not comply with professional methods or that does not respect the technical characteristics of the Product and in particular the maximum working temperature and/or maximum working pressure, or if it is diverted from its usual purpose or in the case of occurrence of a pressure surge or cavitation damage or excessive speed of the fluids or lack of respect of the usual security distances; in the case of total or partial lack of payment by the Customer.

8.2. Liability

8.2.1. TECOFI's liability may only be incurred by the Customer subject to the latter proving a fault attributable to TECOFI, a prejudice and a causal link between the fault and the prejudice. In any event, TECOFI may only accept to bear compensation for a foreseeable, certain, direct, material and physical prejudice – with the exclusion of any unforeseeable, indirect, immaterial, intangible or hypothetical prejudice – with a sufficient causal link with TECOFI's breach of its obligations. (...)

8.2.2. TECOFI's liability may not be incurred, in any event, without this list being complete: in the case of lack of compliance of the Products with standards and regulations that enter into force after acceptance of the Order, in the case of poor storage and/or warehousing of the Products, in the case of poor installation, putting into service and/or handling of the Products by the Customer, in the case of use of the products in abnormal conditions. (...)

8.2.3. Subject to the application of public policy provisions, any claim that the Customer may raise against TECOFI, regardless of the cause and nature of this, is statute-barred after a period of one (1) year as from the damaging event of the claim. After this period and as a special exception to the provisions of article L.110-4 of the French Commercial Code, any legal action that may be taken by the Customer against TECOFI will be automatically statute-barred. TECOFI's liability is, in any event, capped at an amount equal to the amount of the Orders sent by the Customer in the twelve (12) months prior to the date of availability of the litigious Products. (...)

9. RESERVE OF TITLE:

TECOFI MAINTAINS THE OWNERSHIP OF THE PRODUCTS SOLD UNTIL FULL PAYMENT OF THE PRICE. (...) Throughout the reserve of title period, as the risks are transferred in accordance with the terms and conditions stipulated in article 5 of the GTS, the Customer, as custodian, should insure the Products against all risks of damage or responsibility. (...) The parties specifically agree that the Products stored with the Customer are deemed as corresponding to the outstanding invoices. (...) The Customer is authorised to resell or transform the Products delivered in the normal course of its business. Where appropriate, the Customer undertakes to transfer its receivables to TECOFI on sub-purchasers up to the amounts owed. (...)

10. CONFIDENTIALITY – INTELLECTUAL PROPERTY:

10.1. The Customer is banned from disclosing, using, transferring, communicating, operating, directly or indirectly (...) any other document or information provided during the partnership between the Customer and TECOFI. This obligation shall continue to apply for five (5) years after termination of the commercial relations (...)

10.2. The Customer acknowledges that TECOFI holds all of the intellectual property rights on the Products and studies provided to the Customer and that no right to use or reproduce the said rights is granted to the Customer, unless otherwise agreed in writing beforehand. (...)

11. FORCE MAJEURE EVENT:

The performance by the parties of their obligations will be suspended in the case of occurrence of a force majeure event (...) which may hinder or delay the performance. (...) The following are considered automatically as constituting force majeure events (this list is not complete): fire, total or partial strike, terrorism, war, political events, blockade, legal or regulatory amendment, natural disasters, irregularities in deliveries of raw materials and any impossibility of taking supplies. (...)

12. JURISDICTION:

The relations between TECOFI and the Customer are governed by French law, including the provisions of the United Nations Convention on Contracts for the International Sale of Goods (Vienna 1980). All disputes arising between the parties regarding their commercial relations and related in particular to the GTS and/or orders, regardless of the place of delivery, the means of payment accepted, and even in the event of an introduction of third parties and/or several defendants, will be referred to the courts with jurisdiction in the place of Tecofi's registered office. (...)

EXTRAIT DES CONDITIONS GENERALES DE VENTE TECOFI

1. OBJET :

1.1. Les (...) CGV (...) sont applicables pour tous les produits (ci-après, désignés les « Produits ») fournis par la société TECOFI (ci-après dénommée « TECOFI ») auprès de l'ensemble de sa clientèle (ci-après dénommée le/les « Client(s) »). Le présent document ne constitue qu'un extrait des CGV applicables. Le Client ne pourra en aucun cas se prévaloir de cet extrait pour s'opposer à l'application des clauses prévues dans la version complète des CGV non reproduites dans l'extrait.

1.2. (...) Les CGV littéraires sont également consultables sur le site internet de TECOFI (www.tecofi.fr). Toute commande (ci-après la/les « Commande(s) »), quelle qu'en soit l'origine, implique l'adhésion sans réserve aux CGV, qui annulent toute clause contraire pouvant figurer dans les documents types établis unilatéralement par le Client (...) sauf accord dérogatoire exprès et préalable de TECOFI. (...)

2. COMMANDE :

2.1. Tout bon de Commande du Client (ci-après, le « Bon de commande ») doit parvenir à TECOFI par courrier, télécopie, EDI ou e-mail, et préciser la quantité exacte et les références précises des Produits commandés ainsi que les délais de livraison souhaités. Les Commandes ne deviennent définitives qu'après acceptation écrite de TECOFI du Bon de commande, qui se matérialise par l'émission par TECOFI, sous quelque forme écrite que ce soit y compris par voie électronique, d'un accusé de réception de la Commande. (...) Seul le tarif en vigueur au jour de l'acceptation de la Commande par TECOFI sera applicable.

2.2. TECOFI se réserve le droit de refuser les Commandes (...).

2.3. Pour toute commande mise à disposition dans les locaux de TECOFI ou livrée en France métropolitaine, le minimum de Commande est de 150 euros HT. En-deçà de ce seuil, des frais administratifs d'un montant de 30 euros HT seront automatiquement facturés en plus au Client. Pour toute Commande livrée hors du territoire de la France métropolitaine, le minimum de Commande est de 230 euros HT. En-deçà de ce seuil, des frais administratifs d'un montant de 50 euros HT seront automatiquement facturés en plus au Client.

2.4. TECOFI fabrique et/ou distribue également des Produits qui ne figurent pas sur son catalogue de Produits standards. Ainsi, le Client (...) est invité à transmettre à TECOFI, une expression de besoins. Sur la base de cette expression de besoins, TECOFI établira une offre de prix (ci-après, l'« Offre de prix ») spécifique. L'acceptation de l'Offre de prix par le Client supposera la transmission par ce dernier, y compris par voie électronique, d'un accord écrit en tout point conforme à l'Offre de prix émise par TECOFI. (...) L'Offre de prix est valable pendant un délai de trente (30) jours, seule la date de réception de l'accord du Client par TECOFI faisant foi. (...)

2.6. Le Client est seul responsable de l'expression de ses besoins qu'il doit spontanément formuler auprès de TECOFI et ne saurait en conséquence nullement engager la responsabilité de TECOFI en cas de mauvaise expression de besoins, ce que ce dernier reconnaît et accepte expressément. (...)

3. TARIFS :

3.1. Produits standards

3.1.1. S'agissant des Produits standards présents sur le catalogue TECOFI, le tarif est fixé dans les conditions tarifaires applicables au jour de l'acceptation de la Commande (...).

3.1.2. Les tarifs s'entendent hors taxes, hors frais de dossiers techniques et de certificats, d'emballage, de transport et d'assurance. (...).

3.2. Produits spécifiques (...)

3.2.2. L'Offre de prix s'entend hors taxes, hors frais de dossiers techniques et de certificats, d'emballage, de transport et d'assurance. (...)

4. CONDITIONS DE PAIEMENT :

4.1. Les factures émises par TECOFI sont payables dans un délai de trente (30) jours suivant la date d'émission de la facture (...) Aucun escompte pour paiement anticipé n'est accordé par TECOFI à ses Clients.

4.2. Tout retard de paiement entraîne, de plein droit (...) l'application d'une indemnité forfaitaire pour frais de recouvrement de quarante euros (40 €) et des pénalités de retard égales au taux d'intérêt appliqué par la Banque centrale européenne à son opération de refinancement la plus récente majorée de 10 points de pourcentage, sans préjudice de la faculté pour TECOFI de réclamer une indemnisation complémentaire sur justificatif.

4.3. Dans l'hypothèse d'une première Commande adressée par le Client, d'un retard de paiement ou d'impayés, d'une détérioration du crédit du Client (...), de l'obtention par TECOFI de renseignements financiers insuffisants (...), d'une réduction de l'encours maximum accordé (...), TECOFI se réserve le droit : de refuser une Commande du Client ou de suspendre l'exécution des Commandes en cours ; de diminuer le plafond de l'encours consenti au Client ; de réduire les délais de paiement octroyés ou d'exiger un paiement comptant ou un paiement anticipé avant la livraison ; d'exiger l'octroi de toutes garanties de paiement spécifiques que TECOFI jugera nécessaires. A défaut de pouvoir obtenir de telles garanties, pour quelque cause que ce soit, TECOFI se réserve le droit de ne pas honorer les Bons de commandes et/ou de résilier les Commandes en cours. (...)

5. DELAI DE MISE A DISPOSITION, EMBALLAGE, TRANSFERT DES RISQUES, TRANSPORT, RETARDS

Sauf stipulation expresse, écrite et préalable convenue entre les parties, les Produits sont mis à disposition du Client dans les entrepôts ou usines de TECOFI.

5.1. Délai de mise à disposition

5.1.1. (...) Les délais de mise à disposition convenus entre les parties dans le cadre de la Commande ou d'un contrat ne sont donnés qu'à titre indicatif et ne sauraient en aucun cas être considérés comme étant fermes et définitifs. En cas de prise en charge du transport par TECOFI, les délais de livraison qui correspondent aux délais nécessaires pour transporter les Produits des usines de TECOFI dans les entrepôts du Client, s'appliquent en sus du délai de mise à disposition convenue entre les parties. (...)

5.2. Emballage

(...) Les frais d'emballage sont toujours à la charge du Client et s'appliquent en sus du tarif ou de l'Offre de prix. (...)

5.3. Transfert des risques

Sans préjudice des stipulations des contrats types de transports, la livraison et le transfert des risques s'opèrent entre les parties au moment de la mise à disposition des Produits, dans les usines ou entrepôts de TECOFI, avant chargement, le chargement intervenant sous la responsabilité exclusive du Client. Sans préjudice des stipulations des contrats types de transports, dans l'hypothèse d'une prise en charge du transport par TECOFI convenue entre les parties et sous réserve de l'application d'un incoterm spécifique, la livraison et le transfert des risques liés aux Produits s'opèrent au moment de la première présentation du transporteur au lieu de livraison convenue, le déchargement des Produits intervenant sous la responsabilité exclusive du Client.

5.4. Retard de livraison ou mise à disposition

5.4.1. Aucun retard dans la mise à disposition des Produits n'autorise le Client à annuler, totalement ou partiellement, sa Commande ou à refuser la réception des Produits. (...)

5.4.3. Aucune pénalité ne saurait être appliquée de manière unilatérale et non contradictoire par le Client, toute compensation avec une somme due par le Client à TECOFI supposant, en outre, que TECOFI ait expressément reconnu, par écrit et préalablement, la réalité du grief justifiant l'application des pénalités. En tout état de cause, l'application de pénalités ne saurait revêtir un caractère purement forfaitaire et prédéterminé. (...)

5.4.4. En cas de refus des Produits lors de la livraison des Produits ou en cas de refus d'enlèvement des Produits mis à disposition, TECOFI se réserve le droit de facturer des frais de stockage au Client, ce dernier supportant également les risques liés aux Produits à compter de la constatation de ce refus (...).

5.5. Réserves aux transporteurs

En cas d'avaries, pertes, retards, manquants, il appartient au Client de consigner les protestations et réserves régulières auprès du transporteur (...) conformément aux dispositions de l'article L. 133-3 du Code de commerce, et ce, sans préjudice du respect de toute autre disposition légale, réglementaire ou conventionnelle applicable. Un double doit être adressé à TECOFI (...)

6. RECEPTION ET CONFORMITE :

6.1. (...) toutes réclamations relatives à la conformité du Produit ou aux défauts apparents doivent être portées à la connaissance de TECOFI, à peine d'irrecevabilité, par écrit, dans un délai de trois (3) jours à compter de la mise à disposition des Produits ou, en cas de prise en charge du transport par TECOFI, à compter de la livraison des Produits au lieu convenu. Pour être valable, toute réclamation doit mentionner obligatoirement les références des Produits ainsi que le numéro et la date de la Commande concernée. (...)

6.2. Les retours de Produits non-conformes ne sont autorisés et acceptés qu'après accord préalable et écrit de TECOFI. Les Produits doivent être retournés à TECOFI par le Client, sans avoir subi de quelconques modifications dans leur emballage d'origine, dans un délai de trois (3) jours à compter de la reconnaissance par TECOFI de la non-conformité. La responsabilité de TECOFI est strictement limitée au remplacement des Produits non-conformes ou au remboursement des Produits litigieux, à leur prix de facturation, à l'exclusion de tous dommages-intérêts.

6.3. (...) Aucun retour ni reprise ne sera ainsi accepté par TECOFI en cas de mauvaise expression par le Client de ses besoins ou d'erreur d'appréciation par ce dernier des contraintes pouvant peser quant à l'installation et/ou l'intégration des Produits dans un autre équipement. Il appartient ainsi au Client de vérifier l'adéquation entre le Produit et les conditions effectives d'utilisation. (...) En outre, aucun retour ni reprise ne pourra avoir lieu, en raison d'une non-conformité des Produits, dès lors que le Produit livré aura été installé, mis en service, intégré à un autre équipement, etc. (...)

7. INSTALLATION - MISE EN SERVICE :

Les opérations d'installation et de mise en place sont réalisées par le Client, sous sa seule et entière responsabilité, et doivent être effectuées selon les règles de l'art et les prescriptions transmises par TECOFI.

(...) le Client ne saurait prétendre en aucun cas à une quelconque garantie sur les Produits en cas d'installation ou de mise en service des Produits qui n'aurait pas été effectuées dans les règles de l'art ou selon les prescriptions transmises par TECOFI ou pour toute utilisation du Produit non conforme. (...)

8. GARANTIE – RESPONSABILITE – RETRAIT & RAPPEL – PIECES DETACHEES :

8.1. Garantie

8.1.1. TECOFI garantit les Produits pendant douze (12) mois à compter de leur mise à disposition, contre tout défaut non apparent au moment de la mise à disposition ou de la livraison des Produits (...)

8.1.2. En cas de survenance d'un vice caché, le Client est tenu de notifier par écrit à TECOFI, sans délai et au plus tard dans les soixante douze (72) heures ouvrables, la découverte de celui-ci en mentionnant obligatoirement les références des Produits ainsi que le numéro et la date de la Commande concernée. (...) En cas de vice caché imputable au Produit reconnu par les deux

parties, TECOFI s'engage à réparer le Produit défectueux ou à remplacer le Produit défectueux, à l'exclusion de tout autre remède. (...) Sous réserve de l'application de dispositions d'ordre public, TECOFI ne pourra nullement être tenue au paiement d'une quelconque somme à titre de dommages-intérêts en cas de survenance d'un vice caché rendant impropre le Produit à l'usage auquel il est destiné. En tout état de cause, TECOFI ne pourra en aucun cas être tenue d'effectuer à ses frais le démontage du Produit défectueux ni le montage du Produit de remplacement dans les équipements du Client.

8.1.3. La garantie ne s'applique pas, de plein droit : aux éléments qui, par la nature de leurs matériaux ou de leur fonction, subissent une usure naturelle ; aux cas de détérioration ou d'accident qui proviendraient d'une modification ou d'une intervention du Client ou d'un tiers sur le Produit, du non-respect par le Client des notices d'installation, d'utilisation ou de maintenance, d'un défaut de surveillance, de stockage ou d'entretien, de la négligence du Client, d'une installation ou d'une utilisation non conforme aux règles de l'art ou ne respectant pas les caractéristiques techniques du Produit et notamment la température de service maximale et/ou la pression de service maximale, ou détournée de son objet habituel ou en cas de survenance d'un coup de bélier ou de cavitation ou de vitesse excessive des fluides ou de non-respect des distances de sécurité d'usage ; en cas de non-paiement, total ou partiel, par le Client.

8.2. Responsabilité

8.2.1. La responsabilité de TECOFI ne saurait être engagée par le Client que sous réserve que ce dernier établisse une faute imputable à TECOFI, un préjudice et un lien de causalité entre la faute et le préjudice. En tout état de cause, TECOFI ne peut accepter que la prise en charge de l'indemnisation d'un préjudice prévisible, certain, direct, matériel et corporel - à l'exclusion de tout préjudice imprévisible, indirect, immatériel, incorporel ou hypothétique - présentant un lien de causalité suffisant avec un manquement de TECOFI à ses obligations. (...)

8.2.2. La responsabilité de TECOFI ne pourra en aucun cas être engagée, sans que la liste ci-après soit limitative : en cas de non-conformité des Produits aux normes et réglementations qui entreraient en vigueur après l'acceptation de la Commande, en cas de mauvais entreposage et/ou stockage des Produits, en cas de mauvaise installation, mise en service et/ou manipulation des Produits par le Client, en cas d'utilisation des produits dans des conditions anormales. (...)

8.2.3. Sous réserve de l'application de disposition d'ordre public, toute réclamation que le Client pourrait formuler à l'encontre de TECOFI, quelle qu'en soit la cause et la nature, se prescrit dans le délai d'un (1) an à compter du fait générateur de la réclamation. Passé ce délai et par dérogation expresse aux dispositions de l'article L.110-4 du Code de commerce, toute action que pourrait engager le Client à l'encontre de TECOFI sera prescrite de plein droit. La responsabilité de TECOFI est en tout état de cause plafonnée à une somme égale au montant des commandes adressées par le Client dans les douze (12) mois précédant la date de mise à disposition des Produits litigieux. (...)

9. RESERVE DE PROPRIETE :

TECOFI SE RESERVE LA PROPRIETE DES PRODUITS VENDUS JUSQU'AU COMPLET PAIEMENT DU PRIX. (...) Pendant la durée de la réserve de propriété en tant que dépositaire, les risques ayant été transférés dans les conditions visées à l'article 5 des CGV, le Client devra assurer les Produits contre tous les risques de dommages ou de responsabilités, (...) De convention expresse, les Produits en stock chez le Client sont réputés afférents aux factures non réglées. (...) Le Client est autorisé à revendre ou à transformer les Produits livrés dans l'exécution normale de son commerce. Le cas échéant, le Client s'engage à céder à TECOFI ses créances sur les sous-acquéreurs à concurrence des sommes dues. (...)

10. CONFIDENTIALITE - PROPRIETE INTELLECTUELLE :

10.1. Le Client s'interdit de divulguer, utiliser, transmettre, communiquer, exploiter, directement ou indirectement (...) tout autre document ou toute information remis à l'occasion de la relation entre le Client et TECOFI. Cette obligation perdurera pour cinq (5) ans après la cessation des relations commerciales (...).

10.2. Le Client reconnaît que TECOFI est titulaire de l'ensemble des droits de propriété intellectuelle couvrant les Produits et études fournis au Client et qu'aucun droit d'utilisation ou de reproduction desdits droits ne lui est conféré, sauf convention écrite et préalable. (...)

11. FORCE MAJEURE :

L'exécution par les parties de leurs obligations sera suspendue en cas de survenance d'un événement de force majeure (...) qui en général ou retarderait l'exécution. (...) Sous considérés de plein droit comme constitutifs de cas de force majeure, sans que cette liste soit exhaustive, l'incendie, la grève totale ou partielle, le terrorisme, les guerres, les événements politiques, les blocus, une modification légale ou réglementaire, les catastrophes naturelles, les irrégularités dans les livraisons des matières premières ainsi que toute impossibilité d'approvisionnement. (...)

12. ATTRIBUTION DE JURIDICTION :

Les relations entre TECOFI et le Client sont régies par le droit français, en ce compris les dispositions de la Convention des Nations Unies sur les contrats de vente internationale de marchandises (Vienne 1980).

Tous les litiges qui s'élevaient entre les parties à l'occasion de leurs rapports commerciaux et relatifs notamment au CGV et/ou aux commandes, quels que soient le lieu de livraison, le mode de paiement accepté, et ce même dans le cas d'appel en garantie et/ou de pluralité de défendeurs, seront portés devant les tribunaux compétents du ressort du siège social de Tecofi. (...)

EXTRACT FROM THE GENERAL TERMS OF SALE TECOFI

1. PURPOSE:

1.1. The (...) GTS apply to all products (hereafter referred to as the "Products") supplied by the company TECOFI (hereafter referred to as "TECOFI") to the whole of its clientele (hereafter referred to as the "Customer(s)"). This document is only an extract of the applicable GTS. The Customer may not use this extract, under any circumstances, in order to oppose the application of clauses stipulated in the complete version of the GTS and not reproduced in the extract.

1.2. (...) The literary GTS may also be consulted on TECOFI's website (www.tecofi.fr). All orders (hereafter the "Order(s)"), of any origin whatsoever, imply unreserved acceptance of the GTS, which cancel any clause to the contrary indicated in any standard documents established unilaterally by the Customer (...), unless specifically and previously otherwise agreed by TECOFI. (...)

2. ORDER:

2.1. All Order Forms from the Customer (hereafter the "Order Form") must be sent to TECOFI by mail, fax, EDI or email, and specify the precise quantity and precise references of the Products ordered, along with the required delivery lead times. Orders are only final after written acceptance from TECOFI of the Order Form, formalised by a confirmation of receipt by TECOFI of the Order, sent in any written format whatsoever, including electronically. (...) Only the price in force on the date of acceptance of the Order by TECOFI will apply.

2.2. TECOFI reserves the right to refuse Orders (...).

2.3. For any order made available in TECOFI's premises or delivered to Metropolitan France, the minimum Order is 150 Euros excluding tax. Below this amount, additional administrative costs of an amount of 30 Euros excluding tax will be automatically invoiced to the Customer. For any Order delivered outside of the territory of Metropolitan France, the minimum Order is 230 Euros excluding tax. Below this amount, additional administrative costs of an amount of 50 Euros excluding tax will be automatically invoiced to the Customer.

2.4. TECOFI also manufactures and/or distributes Products that are not included in its catalogue of standard Products. Thus, a Customer (...) may inform TECOFI of its requirements. On the basis of this indication of requirements, TECOFI will issue a specific price offer (hereafter the "Price Offer"). The Customer's acceptance of the Price Offer will imply that the latter sends, including electronically, written consent on all aspects of the Price Offer issued by TECOFI. (...) The Price Offer will be valid for a period of thirty (30) days; only the date of receipt of the Customer's consent by TECOFI will be used as evidence of this date. (...)

2.6. The Customer is solely responsible for the indication of the requirements that it must put forward, on its own initiative, to TECOFI and may not therefore incur TECOFI's liability in the case of poor indication of the requirements, which the Customer acknowledges and specifically accepts.

3. PRICES:

3.1. Standard Products

3.1.1. As regards the standard Products present in the TECOFI catalogue, the price is set in accordance with the pricing terms and conditions applicable on the date of acceptance of the Order (...)

3.1.2. The prices are tax-exclusive prices, excluding technical file costs and costs of certificates, packaging, transport and insurance (...).

3.2. Specific Products (...)

3.2.2. The Price Offer is tax-exclusive, excluding technical file costs and costs of certificates, packaging, transport and insurance (...).

4. PAYMENT TERMS:

4.1. The invoices issued by TECOFI are payable within a period of thirty (30) days following the date of issue of the invoice (...). No discount for early payment is granted by TECOFI to its Customers.

4.2. Any late payment will entail the application of a fixed indemnity for debt recovery costs, automatically (...), of forty (€40) Euros and late penalties equal to the interest rate applied by the European Central Bank to its most recent refinancing operation, increased by 10 percentage points, without prejudice to the possibility available to TECOFI to claim additional compensation with supporting evidence.

4.3. In the event of a first Order sent by the Customer, late payment or outstanding invoices, a decline in the Customer's credit situation (...), of insufficient financial information made known to TECOFI (...), or a decrease in the maximum outstanding amount granted (...), TECOFI reserves the right: to refuse the Customer's Order or to suspend the performance of Orders in progress; to reduce the upper limit of the outstanding amount granted to the Customer; to reduce the payment terms granted or to request an immediate payment or a payment before delivery; to request all specific payment guarantees that TECOFI will deem necessary. In the event that TECOFI is unable to obtain such guarantees, for any reason whatsoever, TECOFI reserves the right not to respect the Order Forms and/or to terminate the Orders in progress. (...)

5. AVAILABILITY PERIOD, PACKAGING, TRANSFER OF RISKS, TRANSPORT, DELAYS

Unless otherwise specifically stipulated beforehand in writing by the parties, the Products are made available to the Customer in TECOFI's warehouses or factories.

5.1. Availability period

5.1.1. (...) The availability periods agreed between the parties in relation to the Order or an agreement are only given as an

indication and may not, in any event, be considered as firm and final. In the event that the transport is borne by TECOFI, the delivery lead times which correspond to the periods required for carrying the Products from TECOFI's factories to the Customer's warehouses, apply in addition to the availability period agreed by the parties. (...)

5.2. Packaging

(...) Packaging costs are always borne by the Customer and apply in addition to the price or Price Offer. (...)

5.3. Transfer of risks

Without prejudice to the provisions of standard transport agreements, the delivery and transfer of the risks take place between the parties upon availability of the Products, in TECOFI's factories or warehouses, before loading. The loading takes place under the Customer's exclusive liability. Without prejudice to the provisions of standard transport agreements, in the event that the transport is borne by TECOFI as agreed between the parties and subject to the application of a specific incoterm, the delivery and transfer of the risks related to the Products take place upon the first presentation of the haulage carrier at the agreed place of delivery. The unloading of the Products takes place under the Customer's exclusive liability.

5.4. Late delivery or availability

5.4.1. No delay in the availability of the Products will authorise the Customer to cancel its Order in whole or partially, or to refuse receipt of the Products. (...)

5.4.3. No penalty may be applied unilaterally by the Customer without consultation with TECOFI. Moreover, any offsetting against an amount owed by the Customer to TECOFI implies that TECOFI has specifically acknowledged, in writing and beforehand, the reality of the claim justifying the application of the penalties. In any event, the application of penalties may not be purely fixed and predefined. (...)

5.4.4. In the event of refusal of the Products upon delivery of them or in the event of refusal to collect the Products made available, TECOFI reserves the right to invoice storage costs to the Customer, which must also bear the risks related to the Products as from acknowledgment of this refusal.

5.5. Reservations made to the haulage carriers

In the event of damaged goods, loss, delays, missing goods, the Customer is responsible for indicating the protests and regular reservations to the haulage carrier (...), in accordance with article L. 133-3 of the French Commercial Code, without prejudice to respecting any other legal, regulatory or conventional provisions applicable. A copy must be sent to TECOFI. (...)

6. RECEIPT AND COMPLIANCE:

6.1. (...) all claims related to the compliance of the Product or any visible defects must be made known to TECOFI, in order for them to be admissible, in writing, within a period of three (3) days as from the availability of the Products or, in the case of TECOFI bearing the transport, as from delivery of the Products at the agreed place. In order to be valid, all claims must compulsorily indicate the references of the Products and the number and date of the Order in question. (...)

6.2. Returns of non-compliant Products are only authorised and accepted with TECOFI's prior written consent. The Products must be returned to TECOFI by the Customer, without any amendment whatsoever in their original packaging, within a period of three (3) days as from acknowledgement by TECOFI of the lack of compliance. TECOFI's liability is strictly limited to replacing the non-compliant Products or reimbursing the litigious Products, at their billing price, with the exclusion of any damages.

6.3. (...) No return will thus be accepted by TECOFI in the case of poor indication by the Customer of its requirements or the latter's error of judgment of the constraints involved regarding the installation and/or inclusion of the Products in other equipment. The Customer is thus responsible for checking the appropriateness of the Product with the actual conditions of use. (...) Moreover, no return may take place, for lack of compliance of the Products, when the delivered Product has been installed, put into service, included in another equipment, etc. (...)

7. INSTALLATION - SERVICE:

Installation and fitting operations are carried out by the Customer, under the latter's sole and complete responsibility, and must be performed in accordance with the professional methods and the instructions provided by TECOFI.

(...) the Customer may not claim any guarantee whatsoever, under any circumstances, on the Products when they have not been installed or put into service in accordance with professional methods or according to the instructions provided by TECOFI or for any non-compliant use of the Product. (...)

8. WARRANTY – LIABILITY – WITHDRAWAL & RECALL – SPARE PARTS:

8.1. Warranty

8.1.1. TECOFI guarantees the Products for a period of twelve (12) months as from their availability, for any defect that is not visible upon the availability or the delivery of the Products (...).

8.1.2. In the case of a hidden defect, the Customer is required to inform TECOFI in writing, immediately and within seventy-two (72) working hours at the latest, of the discovery of the defect, indicating compulsorily the references of the Products and the number and date of the Order in question. (...) In the event of a hidden defect attributable to the Product and acknowledged by both parties, TECOFI undertakes to repair the faulty Product or to replace it, with the exclusion of any other solution. (...) Subject to the application of public policy rules, TECOFI may not at all be required to pay any amount of damages whatsoever in the case of occurrence of a hidden defect making the Product unfit for its purpose. In any event, TECOFI may not, under any circumstances, be required to dismantle the faulty Product, at its cost, or to assemble the replacement Product in the Customer's equipment.

8.1.3. The warranty does not apply, automatically: to elements which, due to their materials or their purpose, undergo natural wear and tear; to situations of deterioration or accident due to an amendment or intervention by the Customer or a third party on the Product, lack of respect by the Customer of the installation, use or maintenance instructions, faulty surveillance, storage or servicing, Customer's negligence, an installation or use that does not comply with professional methods or that does not respect the technical characteristics of the Product and in particular the maximum working temperature and/or maximum working pressure, or if it is diverted from its usual purpose or in the case of occurrence of a pressure surge or cavitation damage or excessive speed of the fluids or lack of respect of the usual security distances; in the case of total or partial lack of payment by the Customer.

8.2. Liability

8.2.1. TECOFI's liability may only be incurred by the Customer subject to the latter proving a fault attributable to TECOFI, a prejudice and a causal link between the fault and the prejudice. In any event, TECOFI may only accept to bear compensation for a foreseeable, certain, direct, material and physical prejudice – with the exclusion of any unforeseeable, indirect, immaterial, intangible or hypothetical prejudice – with a sufficient causal link with TECOFI's breach of its obligations. (...)

8.2.2. TECOFI's liability may not be incurred, in any event, without this list being complete: in the case of lack of compliance of the Products with standards and regulations that enter into force after acceptance of the Order, in the case of poor storage and/or warehousing of the Products, in the case of poor installation, putting into service and/or handling of the Products by the Customer, in the case of use of the products in abnormal conditions. (...)

8.2.3. Subject to the application of public policy provisions, any claim that the Customer may raise against TECOFI, regardless of the cause and nature of this, is statute-barred after a period of one (1) year as from the damaging event of the claim. After this period and as a special exception to the provisions of article L.110-4 of the French Commercial Code, any legal action that may be taken by the Customer against TECOFI will be automatically statute-barred. TECOFI's liability is, in any event, capped at an amount equal to the amount of the Orders sent by the Customer in the twelve (12) months prior to the date of availability of the litigious Products. (...)

9. RESERVE OF TITLE:

TECOFI MAINTAINS THE OWNERSHIP OF THE PRODUCTS SOLD UNTIL FULL PAYMENT OF THE PRICE. (...) Throughout the reserve of title period, as the risks are transferred in accordance with the terms and conditions stipulated in article 5 of the GTS, the Customer, as custodian, should insure the Products against all risks of damage or responsibility. (...) The parties specifically agree that the Products stored with the Customer are deemed as corresponding to the outstanding invoices. (...) The Customer is authorised to resell or transform the Products delivered in the normal course of its business. Where appropriate, the Customer undertakes to transfer its receivables to TECOFI on sub-purchasers up to the amounts owed. (...)

10. CONFIDENTIALITY – INTELLECTUAL PROPERTY:

10.1. The Customer is banned from disclosing, using, transferring, communicating, operating, directly or indirectly (...) any other document or information provided during the partnership between the Customer and TECOFI. This obligation shall continue to apply for five (5) years after termination of the commercial relations (...)

10.2. The Customer acknowledges that TECOFI holds all of the intellectual property rights on the Products and studies provided to the Customer and that no right to use or reproduce the said rights is granted to the Customer, unless otherwise agreed in writing beforehand. (...)

11. FORCE MAJEURE EVENT:

The performance by the parties of their obligations will be suspended in the case of occurrence of a force majeure event (...) which may hinder or delay the performance. (...) The following are considered automatically as constituting force majeure events (this list is not complete): fire, total or partial strike, terrorism, war, political events, blockade, legal or regulatory amendment, natural disasters, irregularities in deliveries of raw materials and any impossibility of taking supplies. (...)

12. JURISDICTION:

The relations between TECOFI and the Customer are governed by French law, including the provisions of the United Nations Convention on Contracts for the International Sale of Goods (Vienna 1980). All disputes arising between the parties regarding their commercial relations and related in particular to the GTS and/or orders, regardless of the place of delivery, the means of payment accepted, and even in the event of an introduction of third parties and/or several defendants, will be referred to the courts with jurisdiction in the place of Tecofi's registered office. (...)

Tecofi'Φ

VALVE DESIGNER - FRANCE

TECOFI FRANCE

Siège social et logistique | Headquarters and logistics
83 rue Marcel Mérieux - 69960 Corbas - FRANCE

Administratif et vente | Administrative and sales offices
8 rue Joseph Nicéphore Niépce - 69740 Genas - FRANCE

+33 (0)4 72 79 05 79 | +33 (0)4 78 90 19 19
✉ sales@tecofi.fr | +33 623 898 706 (WhatsApp Chat)

www.tecofi.fr

CONSTRUISONS NOTRE FUTUR
Let's build our future...