

## KNIFE GATE VALVE DUCTILE IRON BODY

TECHNICAL PASSPORT

### KNIFE GATE VALVE WITH CHAINWHEEL RISING STEM DUCTILE IRON BODY - BETWEEN FLANGES PN10

VG 4400-01

#### APPLICATION

The knife gate valve is particularly suitable for the most difficult applications.

**Area of use:** water treatment networks, pulp and paper industry, chemical plants, winemaking, cement works, pneumatic transport, storage.



**Fluids:** water, sewage, pulp, pasty products, powdery, granular, fibrous, abrasive and crystallizing.

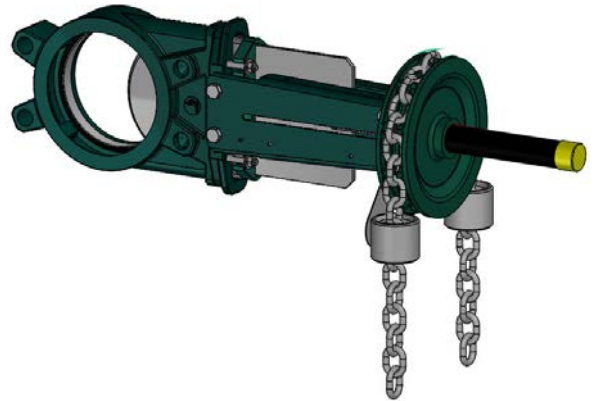

#### GENERAL CHARACTERISTICS

**Range:** from DN50 to DN600.

- Knife Gate Valve on/off or regulation with rising stem.
- Molded monobloc body
- Unidirectional water tightness: Flow direction indicated on the body with an arrow.
- Installation between flanges ISO PN10.
- Small retention zone.
- Gate with a beveled cutting edge guided in the body with little backlash.
- Guaranteed closure, without risk of blockage.
- Standard polished gate, soft contact with the gaskets.
- Very resistant ductile iron packing flange avoids risks of breaks.
- Operating force reduced thanks to the elasticity of the gaskets.
- Pre-formed profiled sheet metal support plates from DN50 to DN300 for accessory or kit mounting.
- Full flow when fully opened, ensuring a high flow rate with low head loss.
- Flow regulation possible for pasty or abrasive fluids with installation of a deflector.

#### STANDARDS

<b>Design</b>	Manufacture according to the requirements of the European directive n° 2014/68/UE «Equipment under pressure» : modulate H.					
	In option: product conform to European directive ATEX «ATmosphère EXplosive» n° 2014/34/UE.					
<b>Face to face</b>	Face to face dimension according to TECOFI standard					
<b>Connection</b>	Mounting between flanges in accordance with EN1092-2 and DIN 2501 : ISO PN10					
<b>Tests</b>	Pressure test according to standards EN12266-1, DIN 3230, BS 5154 and ISO 5208.					
	DN	Body	Seat	DN	Body	Seat
	DN50-250 :	15 bar	11 bar	DN300-450:	10.5 bar	7.7 bar
	DN500-600:	6 bar	4.4 bar			

#### PRODUCT APPROVALS



#### Tecofi France

83 rue Marcel Mérieux - 69960 Corbas  
Tél. +33 (0)4 72 79 05 79 - Fax. +33 (0)4 78 90 19 19  
E-mail : sales@tecofi.fr - [www.tecofi.fr](http://www.tecofi.fr)



## KNIFE GATE VALVE DUCTILE IRON BODY

### TECHNICAL PASSPORT

VG 4400-01

#### CONSTRUCTION

The valves are coated with epoxy paint to protect them against corrosion

Component	Coating
Body (1)	Epoxy powder RAL 6005 150 microns
Chainwheel (23)	
Support plate (8)	Liquid epoxy RAL 6005 70 microns
Glang packing (7)	
Protection tube (24)	Liquid epoxy RAL 9005 70 microns

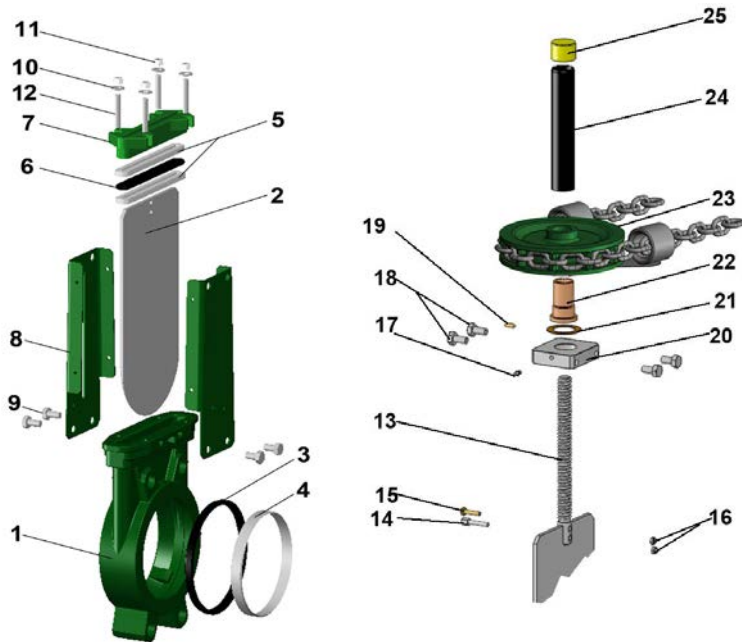

Pos.	Q-ty	Désignation	Material	Equivalences		
				DIN	ASTM	BS
1	1	Body	Ductile iron EN-GJS-500-7	GGG 50	A536 65-70-50-05	1563 EN-JS1050
2	1	Gate	Stainless steel X5CrNi 18-10	X5CrNi 18 10	A 182 AISI 304	1449-2 304 S15
3	1	Seat gasket (1)	NBR			NBR
4	1	Support ring (1)	Stainless steel X5CrNi 18-10	X5CrNi 18 10	A 182 AISI 304	1449-2 304 S15
5	2	Packing	PTFE			
6	1	O-Ring	NBR			NBR
7	1	Packing gland	Ductile iron EN-GJS-500-7	GGG 50	A536 65-70-50-05	1563 EN-JS1050
8	2	Support plate	Steel			
9	4**	Screw	Stainless steel A2-70			
10	4*	Washer	Stainless steel A2-70			
11	4*	Nut	Stainless steel A2-70			
12	4*	Tie rod	Stainless steel A2-70			
13	1	Stem	Stainless steel 13% Cr	X12Cr13	AISI 410	
14	1	Detection screw	Stainless steel X5CrNi 18 10	X5CrNi 18 10	A 182 AISI 304	1449-2 304 S15
15	1	Screw	Stainless steel A2-70			
16	2	Nut	Stainless steel X5CrNi 18 10	X5CrNi 18 10	A 182 AISI 304	1449-2 304 S15
17	1	Greaser	Stainless steel X5CrNi 18 10	X5CrNi 18 10	A 182 AISI 304	1449-2 304 S15
18	4	Screw	Stainless steel A2-70			
19	1	Screw	Stainless steel A2-70			
20	1	Nut support	Zinc plated steel			
21	1	Support washer	Bronze CuSn5Zn8Pb5-C			
22	1	Nut	Bronze CuSn5Zn8Pb5-C			
23	1	Chainwheel***	Cast iron EN-GJL-250	GG25	A48 class 40B	1452 Grade 250
24	1	Protection tube	Steel A45			
25	1	Plug	Polyurethane			

\* - 8 for DN350-400; \*\* - 12 for DN450-600 \*\*\* - Zinc plated steel chain and stainless steel guide  
(1) - Parts missing on metal/metal sealing

**Tecofi France**

83 rue Marcel Mériex - 69960 Corbas  
Tél. +33 (0)4 72 79 05 79 - Fax. +33 (0)4 78 90 19 19  
E-mail : sales@tecofi.fr - [www.tecofi.fr](http://www.tecofi.fr)



## KNIFE GATE VALVE DUCTILE IRON BODY

TECHNICAL PASSPORT

VG 4400-01

### DIMENSIONS

DN		A	B	C	D	Ø V	H	Weight (kg)
mm	inch							
50	2"	40	266	124	83	200	371	11.5
65	2"1/2	40	291	139	83	200	411	12.8
80	3"	50	316	154	83	200	436	13.4
100	4"	50	361	174	83	200	511	15.5
125	5"	50	399	189	93	200	584	19.4
150	6"	60	450	220	93	200	655	22.5
200	8"	60	564	275	108	250	834	41.8
250	10"	70	656	326	108	250	971	54.0
300	12"	70	768	380	108	300	1153	72.0
350	14"	96	871	438	290	300	1306	131.0
400	16"	100	981	494	290	300	1497	162.0
450	18"	106	1076	547	290	300	1611	198.0
500	20"	110	1186	613	290	400	1833	217.0
600	24"	110	1386	716	290	400	2084	304.0

Dimension A - face to face according to TECOFI standard

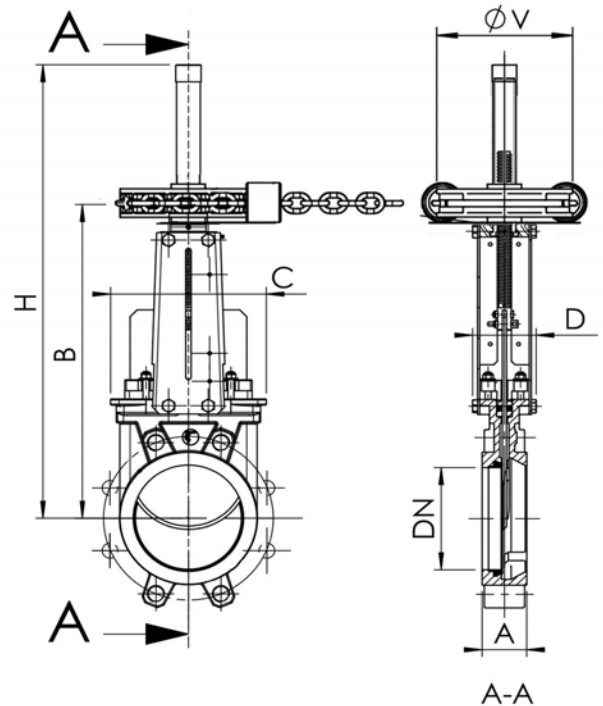

### MOUNTING

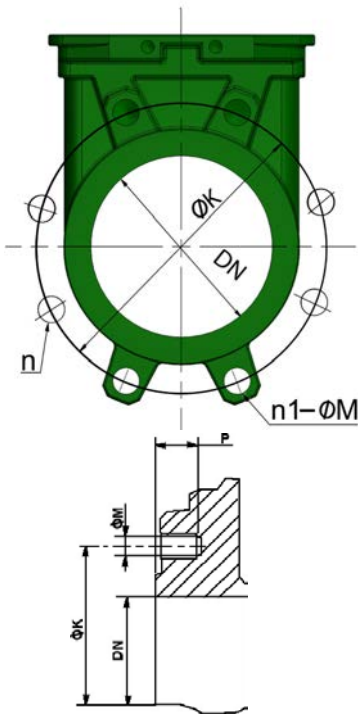

Body detail

DN		Maximum pressure <sub>ei</sub> (bar)	n	n <sub>1</sub> -ØM	P	ØK
mm	inch					
50	2"	10	4	4xM16	8	125
65	2"1/2	10	4	4xM16	8	145
80	3"	10	8	4xM16	9	160
100	4"	10	8	4xM16	9	180
125	5"	10	8	4xM16	9	210
150	6"	10	8	4XM20	10	240
200	8"	10	8	4XM20	12	295
250	10"	10	12	8XM20	12	350
300	12"	7	12	8XM20	19	400
350	14"	7	16	10XM20	20	460
400	16"	7	16	10XM24	24	515
450	18"	7	20	14XM24	24	565
500	20"	4	20	14XM24	24	620
600	24"	4	20	14XM27	24	725

n- total number of holes  
n<sub>1</sub>- number of threaded holes

**Tecofi France**

83 rue Marcel Mérieux - 69960 Corbas  
Tél. +33 (0)4 72 79 05 79 - Fax. +33 (0)4 78 90 19 19  
E-mail : sales@tecofi.fr - [www.tecofi.fr](http://www.tecofi.fr)



## KNIFE GATE VALVE DUCTILE IRON BODY

### TECHNICAL PASSPORT

VG 4400-01

#### WORKING CONDITIONS

Maximum working pressure: DN50-250 : 10 bar  
 DN300-450 : 7 bar  
 DN500-600 : 4 bar

Maximum working temperature : -10°C / +80°C (NBR joint in standard)

⚠ The above mentioned pressures are only valid if the direction of assembly indicated by the arrow on the valves is observed.

#### Upstream/downstream tightness



Elastomer tightness

Metal/metal tightness

#### Packing tightness

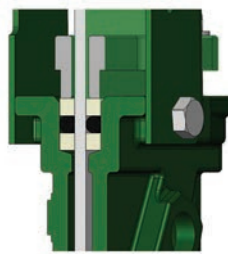

PTFE/Elastomer

#### Tightness in option

Tightness	maximum temperature
Metal/metal	Tmax : -10°C / +80°C
White NBR	Tmax : -10°C / +80°C
EPDM	Tmax : -10°C / +130°C
Silicone	Tmax : -10°C / +170°C
FPM (Type Viton®)	Tmax : -10°C / +170°C
PTFE	Tmax : +4°C / +170°C
CSM (Type Hypalon®)	Tmax : +4°C / +80°C

⚠ To ensure a satisfactory tightness, when using the PTFE gasket, the operating pressure must be at least 1 bar.

#### FLOW RATES

Flow rates of valves under different differential pressure (m<sup>3</sup>/h)

DN		0.2 bar	0.4 bar	0.6 bar	0.8 bar	1.0 bar
mm	inch					
50	2"	93	134	165	185	206
65	2 1/2"	129	180	213	268	309
80	3"	191	309	371	422	494
100	4"	443	618	721	824	927
125	5"	700	927	1133	1339	1545
150	6"	927	1339	1545	1906	2060
200	8"	1597	2369	2987	3399	4017
250	10"	2472	3502	4429	5150	5665
300	12"	4120	5665	6798	7828	8755
350	14"	5335	7372	8730	9700	11640
400	16"	6693	9312	11640	13580	15520
450	18"	8342	12610	14550	16490	18430
500	20"	9700	14550	17460	19400	22310
600	24"	14550	19400	25220	29100	33950

The column of the table under 1 bar gives the values of the Kvs of the valves.

#### Tecofi France

83 rue Marcel Mérieux - 69960 Corbas  
 Tél. +33 (0)4 72 79 05 79 - Fax. +33 (0)4 78 90 19 19  
 E-mail : sales@tecofi.fr - [www.tecofi.fr](http://www.tecofi.fr)

