

Ref. : XMOTBM-SME

Rev. : Initial

Date : 30/04/2015

Page : 1/1

ELECTRIC ACTUATOR SME

XMOTBM-SME



APPLICATION

Maneuvering of mixing 3 or 4-way valves.

GENERAL CHARACTERISTICS

Control by regulating system through 3 points.
 Connection by terminal block or cable (1.4 m, 3x 0.75mm²).
 Quarter turn rotation (angle 90°)
 IP40 protection class.
 Voltage 230V, consumption 2.5 W.
 Maximum torque: 5 Nm.
 Running time: 140 s.



DIMENSIONS

A	B	C	H	H1	Weight (kg)
80	93	33	90,5	75	0,5

WORKING CONDITIONS

Ambient temperature : 0°C / +50°C

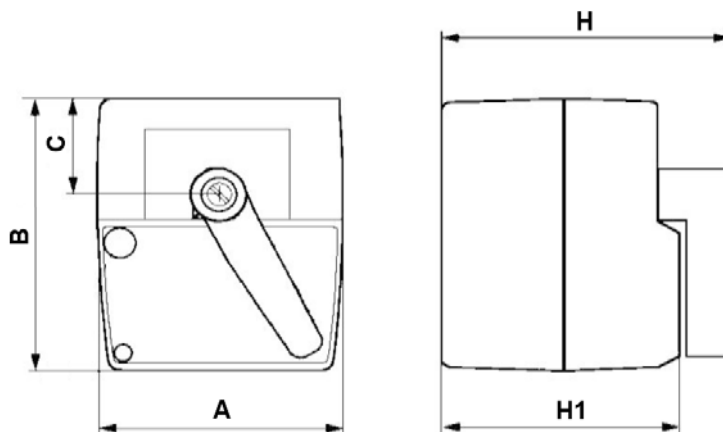

CONNECTION SCHEMES



Phase upon brown wire
 The actuator rotates in the anti-clockwise direction.

1

Phase upon white wire
 The actuator rotates in the clockwise direction.

2

