

DOUBLE EXCENTRIC BUTTERFLY VALVE TYPE TECWAT

PN16 FLANGED DOUBLE EXCENTRIC BUTTERFLY VALVE WITH GEAR BOX IP67 AND MANEUVERING SQUARE

VP 4248-051

APPLICATION

Tecwat type butterfly valves are intended to be used for ON/OFF operations in fluid transfer circuits.

Area of use: water networks, production plants, pumping stations, fire circuits on industrial site, etc.



Fluids: water, drinking water.

GENERAL CHARACTERISTICS

TECWAT model: long pattern.

- Design according to NF EN 593.
- Range : from DN80 to DN1600.
- Bi-directional sealing with a preferred mounting direction indicated by the arrow on the body.
- Double eccentric butterfly valve prevents wear due to the stainless steel seat attached to the body.
- Seal on disc retained by a stainless steel retaining ring.
- Optimized maneuvering torque.
- Low pressure drop.
- Operating by IP67 gear box.
- Equipped with an ISO 5210 actuator mounting plate.

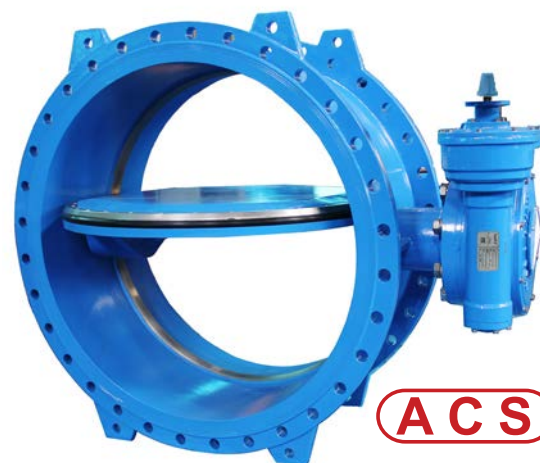

ACS

DRY SHAFT

STANDARDS

Design	Complies with standard EN 593
Face to face	Face to face according to standard NF EN 558 serie 14.
Connection	ISO PN16 flange mounting according to standard EN1092-2.
Tests	Hydraulic tests carried out according to the standard EN12266-1: -Body : 24 bar -Seat : 17.6 bar

PRODUCT APPROVALS

Certificat WRAS n° 1607394

Health compliance certificate n° 19 ACC LY 582



EN 1074



Tecofi France

83 rue Marcel Mérieux - 69960 Corbas
Tél. +33 (0)4 72 79 05 79 - Fax. +33 (0)4 78 90 19 19
E-mail : sales@tecofi.fr - www.tecofi.fr



DOUBLE EXCENTRIC BUTTERFLY VALVE TYPE TECWAT

CONSTRUCTION

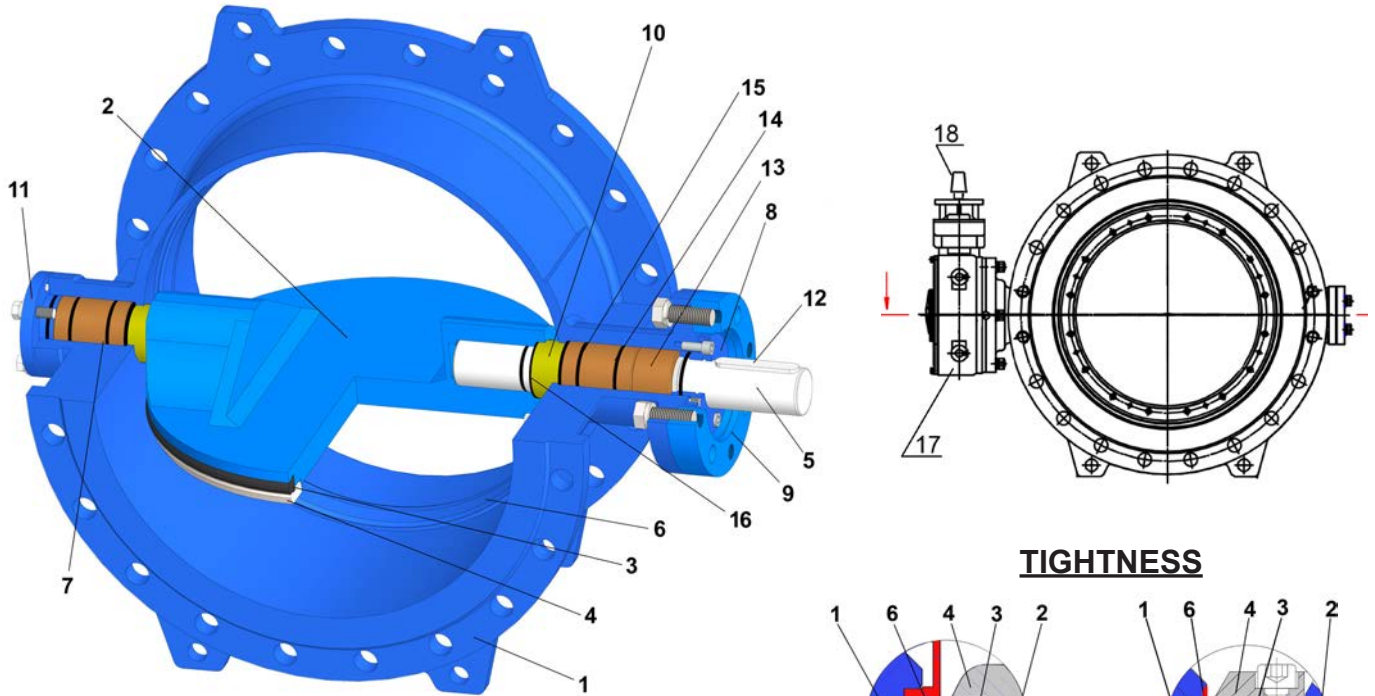

Component	Coating
Body & disc	Epoxy powder RAL 5015 250 microns

TIGHTNESS

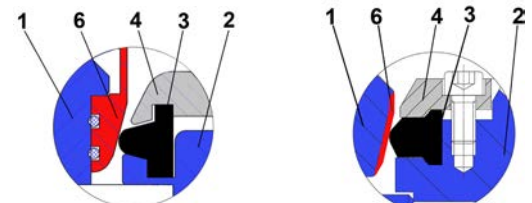

DN80-150

DN200-1600

Pos.	Description	Material	Equivalences		
			DIN	ASTM	BS
1	Body	Ductile iron ENGJS-500-7	GGG 50	ASTM 80-55-06	BS 500/7
2	Disc	Ductile iron ENGJS-500-7	GGG 50	ASTM 80-55-06	BS 500/7
3	Sealing gasket	EPDM			
4	Retaining ring	Stainless steel X5CrNi 18 10	X5CrNi 18 10	A 182 AISI 304	1449-2 304 S15
5	Shaft	Stainless steel 420	1.4021	AISI 420	420 S 37
6	Body seal ring	Stainless steel X5CrNi 18 10	X5CrNi 18 10	A 182 AISI 304	1449-2 304 S15
7	Bearing	Al-Bronze	G-CuAl10Fe	C95200	ZCuAl10Fe3
8	Packing gland	Ductile iron	GGG 50	ASTM 80-55-06	BS 500/7
9	Mounting flange	Steel Q235B	EN 10025-2	ASTM A36	S235JR
10	Adjusting bushing	Al-Bronze	G-CuAl10Fe	C95200	ZCuAl10Fe3
11	Cover	Ductile iron ENGJS-500-7	GGG 50	ASTM 80-55-06	BS 500/7
12	Key	Stainless steel 420	1.4021	AISI 420	420 S 37
13	Shaft bushing	Al-Bronze	G-CuAl10Fe	C95200	ZCuAl10Fe3
14	O seal ring	EPDM			
15	Shaft gasket	EPDM			
16	Gasket	EPDM			
17	Gear box	Ductile iron			
18	Square	Ductile iron			

Tecofi France

83 rue Marcel Mérioux - 69960 Corbas

Tél. +33 (0)4 72 79 05 79 - Fax. +33 (0)4 78 90 19 19

E-mail : sales@tecofi.fr - www.tecofi.fr



DOUBLE EXCENTRIC BUTTERFLY VALVE TYPE TECWAT

DIMENSIONS

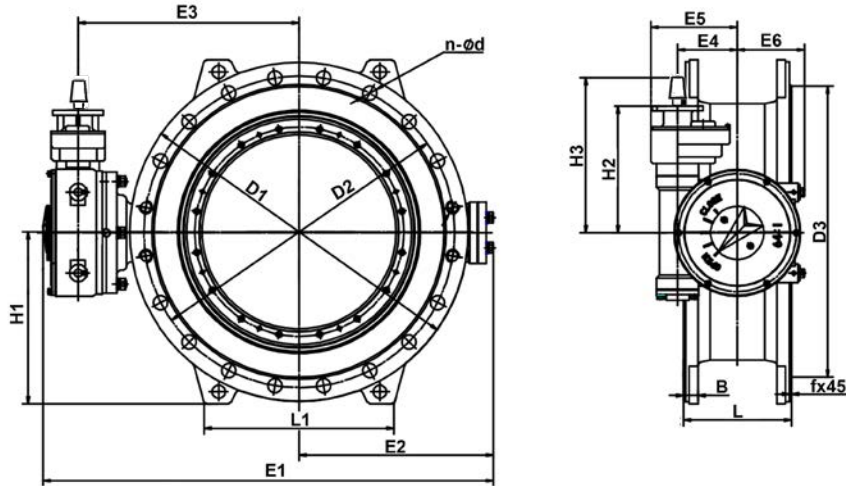

DN	ØD1	ØD2	ØD3	B	f	L	n-Ød	H1	H2	H3	E1	E2	E3	E4	E5	E6	L1	ISO 5210	Weight (kg)	
mm	inch																			
80	3"	200	160	132	19	3	180	8-Ø19	-	-	297	100	-	-	-	-	-	F07	17	
100	4"	220	180	156	19	3	190	8-Ø19	110	-	322	110	-	43	73	64	-	F07	23	
125	5"	250	210	184	19	3	200	8-Ø19	125	137	193	350	125	-	-	-	-	F07	28	
150	6"	285	240	211	19	3	210	8-Ø23	147.5	137	193	407	142.5	-	64	-	86	F10	31	
200	8"	340	295	266	20	3	230	12-Ø23	175	137	193	534	195	278	64	99	86	196	F10	52
250	10"	405	355	319	22	3	250	12-Ø28	207.5	178	233	610	234	308	94	135	115	240	F10	90
300	12"	460	410	370	24.5	4	270	12-Ø28	235	178	233	685	258	350	94	135	115	275	F10	103
350	14"	520	470	429	26.5	4	290	16-Ø28	265	192	283	756	298	385	120	169	138	290	F10	153
400	16"	580	525	480	28	4	310	16-Ø31	295	192	283	871	339	461	120	169	138	320	F10	178
450	18"	640	585	548	30	4	330	20-Ø31	325	317	378	952	379	499	148	186	138	360	F10	245
500	20"	715	650	609	31.5	4	350	20-Ø34	362.5	315	376	1034	404	535	148	214	166	395	F10	316
600	24"	840	770	720	36	5	390	20-Ø37	425	315	376	1117	480	548	148	214	166	470	F10	442
700	28"	910	840	794	39.5	5	430	24-Ø37	460	346	407	1308	563	640	185	265	196	480	F10	613
800	32"	1025	950	901	43	5	470	24-Ø41	517.5	346	407	1426	623	698	185	265	196	560	F10	808
900	36"	1125	1050	1001	46.5	5	510	28-Ø41	567.5	390	451	1612	698	789	230	333	232	618	F10	1130
1000	40"	1255	1170	1112	50	5	550	28-Ø44	635.5	451	512	1773	766	882	230	368	232	600	F10	1404
1100	44"	1355	1270	1218	55	5	590	32-Ø44	682.5	507	568	1967	795	1008	315	453	360	750	F10	2229
1200	48"	1485	1390	1328	57	5	630	32-Ø50	747.5	507	568	2112	810.5	1038	315	453	360	800	F10	2308
1400	56"	1685	1590	1530	60	5	710	36-Ø50	847.5	599	660	2529	1063	1253	412	613	440	920	F10	3735
1500	60"	1820	1710	1640	62.5	5	750	36-Ø57	915	599	660	2633	1120	1300	412	613	390	1000	F10	3389
1600	64"	1930	1820	1750	65	5	790	36-Ø57/4-M52	970	599	660	2754	1172	1369	412	613	440	1060	F10	4459

ISO 5210 UPPER FLANGE DIMENSIONS

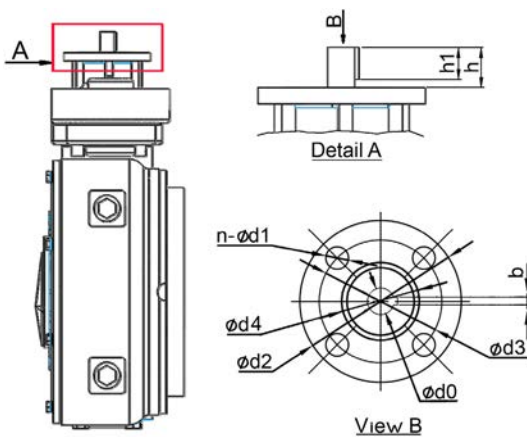

DN	ISO 5210										Number of turns	Torque * (Nm)
mm	inch	Embase	Ød0	n-Ød1	Ød2	Ød3	Ød4	h	bxh1			
80	3"	F07	15	4-Ø8	90	70	55	18	5X16	8	5	
100	4"	F07	15	4-Ø8	90	70	55	18	5X16	8	11	
125	5"	F07	15	4-Ø8	90	70	55	18	5X16	8	16	
150	6"	F10	20	4-Ø10	125	102	70	28	6X20	10	15	
200	8"	F10	20	4-Ø10	125	102	70	28	6X20	10	33	
250	10"	F10	20	4-Ø10	125	102	70	28	6X20	12	49	
300	12"	F10	20	4-Ø10	125	102	70	28	6X20	12	69	
350	14"	F10	20	4-Ø10	125	102	70	30	6X25	20	63	
400	16"	F10	20	4-Ø10	125	102	70	30	6X25	20	84	
450	18"	F10	20	4-Ø10	125	102	70	30	6X25	20	32	
500	20"	F10	20	4-Ø10	125	102	70	30	6X25	64	54	
600	24"	F10	20	4-Ø10	125	102	70	30	6X25	64	83	
700	28"	F10	20	4-Ø10	125	102	70	30	6X25	96	80	
800	32"	F10	20	4-Ø10	125	102	70	30	6X25	96	118	
900	36"	F10	20	4-Ø10	125	102	70	30	6X25	198.9	75	
1000	40"	F10	20	4-Ø10	125	102	70	30	6X25	382.2	52	
1100	44"	F10	20	4-Ø10	125	102	70	30	6X25	421.4	61	
1200	48"	F10	20	4-Ø10	125	102	70	30	6X25	421.4	75	
1400	56"	F10	20	4-Ø10	125	102	70	30	6X25	641.25	70	
1500	60"	F10	20	4-Ø10	125	102	70	30	6X25	641.25	74	
1600	60"	F10	20	4-Ø10	125	102	70	30	6X25	641.25	107	

* Values without safety factor

Tecofi France

83 rue Marcel Mérioux - 69960 Corbas

Tél. +33 (0)4 72 79 05 79 - Fax. +33 (0)4 78 90 19 19

E-mail : sales@tecofi.fr - www.tecofi.fr



DOUBLE EXCENTRIC BUTTERFLY VALVE TYPE TECWAT

WORKING CONDITIONS

Maximum working pressure : 16 bar.
Maximum working temperature : + 80 °C.

FLOW FACTOR - Kv

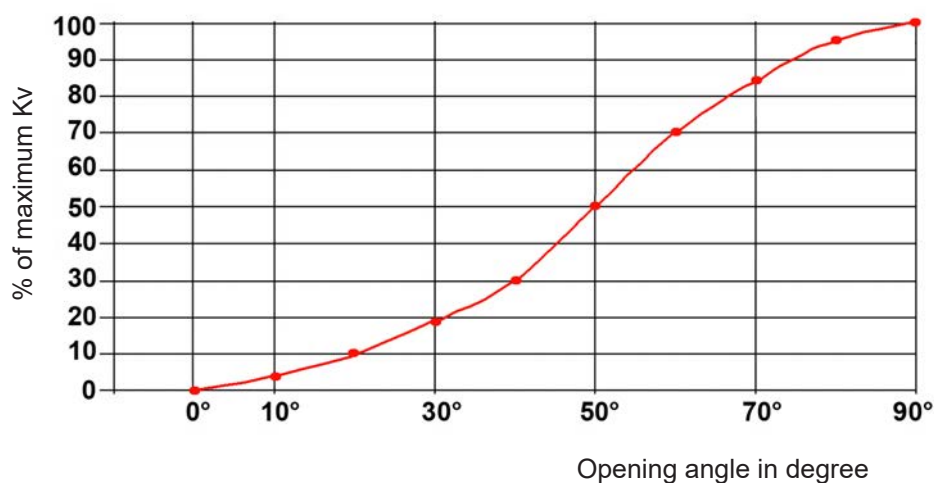

DN	mm	200	250	300	350	400	450	500	600	700	800	900	1000	1100	1200	1400	1600
	inch	8"	10"	12"	14"	16"	18"	20"	24"	28"	32"	36"	40"	44"	48"	56"	64"
Kvs		1880	3800	4950	8000	10900	14200	18250	28000	40500	55100	74000	93338	116213	142516	167310	264433

Values given for information

Tecofi France

83 rue Marcel Mérieux - 69960 Corbas
Tél. +33 (0)4 72 79 05 79 - Fax. +33 (0)4 78 90 19 19
E-mail : sales@tecofi.fr - www.tecofi.fr

