

DOUBLE EXCENTRIC BUTTERFLY VALVE TYPE TECWAT

PN10 FLANGED DOUBLE EXCENTRIC BUTTERFLY VALVE WITH IP67 GEAR BOX AND SQUARE

VP 4208-084AEP

APPLICATION

Tecwat type butterfly valves are intended to be used for ON/OFF operations in fluid transfer circuits.

Area of use: water networks, production plants, pumping stations, fire circuits on industrial site, etc.



Fluids: water, drinking water.

GENERAL CHARACTERISTICS

TECWAT model: long pattern.

- Design according to NF EN 595.
- Range : from DN200 to DN1600.
- Bi-directional sealing with a preferred mounting direction indicated by the arrow on the body.
- Pinned stem/disc connection.
- Double eccentric butterfly valve prevents wear due to the stainless steel seat attached to the body.
- Seal on disc retained by a stainless steel retaining ring.
- Optimized maneuvering torque.
- Low pressure drop.
- Operating by IP67 gear box.
- Equipped with an ISO 5210 actuator mounting plate.
- Anti-clockwise closing



ACS

DRY SHAFT

STANDARDS

Design	Complies with standard EN 593
Face to face	Face to face according to standard NF EN 558 serie 14.
Connection	ISO PN10 flange mounting according to standard EN1092-2.
Tests	Hydraulic tests carried out according to the standard EN12266-1: -Body : 15 bar -Seat : 11 bar

PRODUCT APPROVALS

Certificat WRAS n° 1607394

Health compliance certificate n° 19 ACC LY 582



EN 1074



Tecofi France

83 rue Marcel Mérioux - 69960 Corbas

Tél. +33 (0)4 72 79 05 79 - Fax. +33 (0)4 78 90 19 19

E-mail : sales@tecofi.fr - www.tecofi.fr

ISO 9001
ISO 14001
BUREAU VERITAS
Certification



DOUBLE EXCENTRIC BUTTERFLY VALVE TYPE TECWAT

CONSTRUCTION

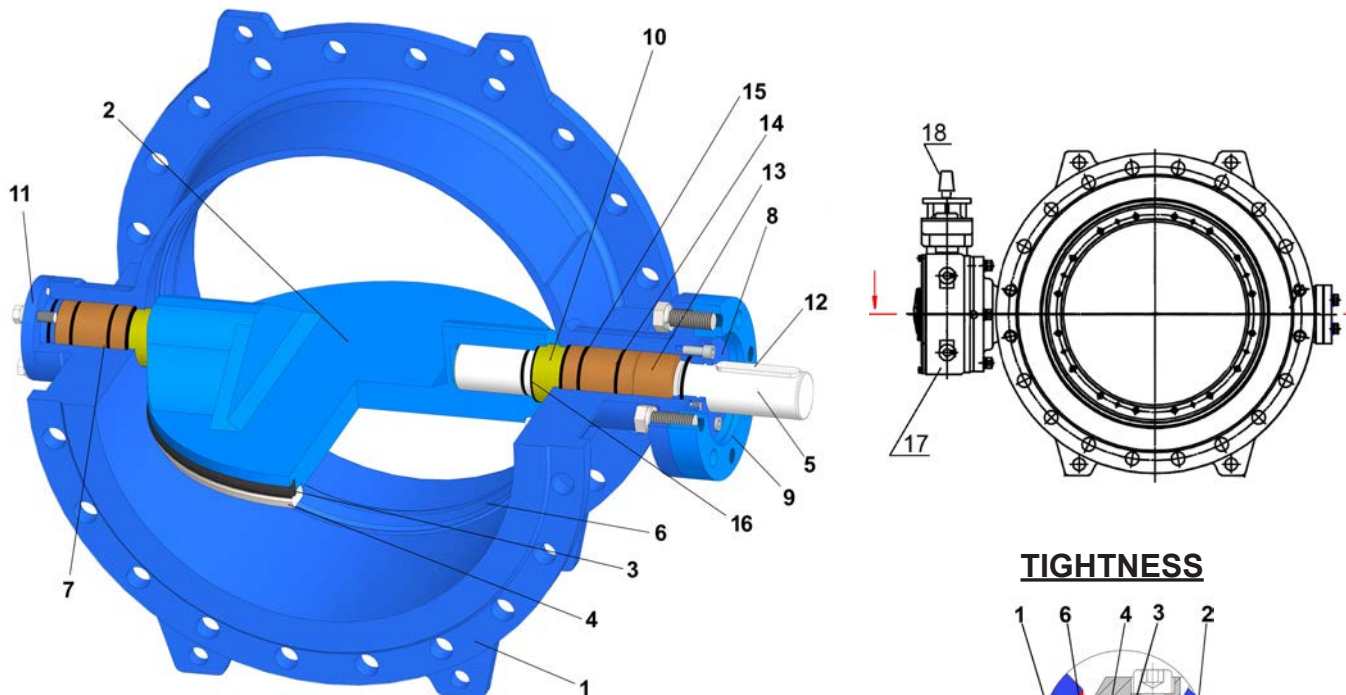

Component	Coating
Body & Disc	Epoxy powder RAL 5015 250 microns

Pos.	Description	Material	Equivalences		
			DIN	ASTM	BS
1	Body	Ductile iron ENGJS-500-7	GGG 50	ASTM 80-55-06	BS 500/7
2	Disc	Ductile iron ENGJS-500-7	GGG 50	ASTM 80-55-06	BS 500/7
3	Sealing gasket	EPDM			
4	Retaining ring	Stainless steel X5CrNi 18 10	X5CrNi 18 10	A 182 AISI 304	1449-2 304 S15
5	Shaft	Stainless steel 420	1.4021	AISI 420	420 S 37
6	Body seal ring	Stainless steel X5CrNi 18 10	X5CrNi 18 10	A 182 AISI 304	1449-2 304 S15
7	Bearing	Al-Bronze	G-CuAl10Fe	C95200	ZCuAl10Fe3
8	Packing gland	Ductile iron	GGG 50	ASTM 80-55-06	BS 500/7
9	Mounting flange	Steel Q235B	EN 10025-2	ASTM A36	S235JR
10	Adjusting bushing	Al-Bronze	G-CuAl10Fe	C95200	ZCuAl10Fe3
11	Cover	Ductile iron ENGJS-500-7	GGG 50	ASTM 80-55-06	BS 500/7
12	Key	Stainless steel 420	1.4021	AISI 420	420 S 37
13	Shaft bushing	Al-Bronze	G-CuAl10Fe	C95200	ZCuAl10Fe3
14	O seal ring	EPDM			
15	Shaft gasket	EPDM			
16	Gasket	EPDM			
17	Gear box	Ductile iron			
18	Square	Ductile iron			

Tecofi France

83 rue Marcel Mérioux - 69960 Corbas
Tél. +33 (0)4 72 79 05 79 - Fax. +33 (0)4 78 90 19 19
E-mail : sales@tecofi.fr - www.tecofi.fr



DOUBLE EXCENTRIC BUTTERFLY VALVE TYPE TECWAT

DIMENSIONS

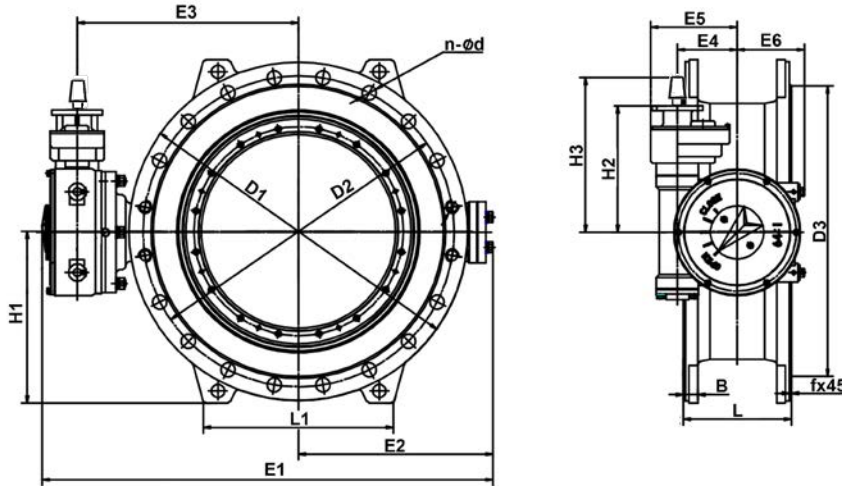

DN		ØD1	ØD2	ØD3	B	f	L	n-Ød	H1	H2	H3	E1	E2	E3	E4	E5	E6	L1	ISO 5210	Weight (kg)
mm	inch																			
200	8"	340	295	266	20	3	230	8-Ø23	175	137	193	534	195	193	64	99	86	196	F10	52
250	10"	395	350	319	22	3	250	12-Ø23	202.7	137	190	590	234	233	64	99	86	240	F10	66
300	12"	460	400	370	24.5	4	270	12-Ø23	227.5	178	233	669	258	233	93.4	135	115	275	F10	96
350	14"	505	460	429	24.5	4	290	16-Ø23	257.5	178	233	747	298	283	93.4	135	115	280	F10	114
400	16"	565	515	480	24.5	4	310	16-Ø28	287.5	192	283	867	329	283	120	169	138	310	F10	158
450	18"	615	565	530	25.5	4	330	20-Ø28	312.5	192	283	952	365	378	120	169	138	340	F10	189
500	20"	670	620	582	26.5	4	350	20-Ø28	340	317	378	1010	398	376	120	186	138	370	F10	238
600	24"	780	725	682	30	5	390	20-Ø31	395	315	376	1119	450	376	148	214	166	430	F10	344
700	28"	895	840	794	32.5	5	430	24-Ø31	452.5	315	376	1217	530	407	148	214	166	480	F10	470
800	32"	1015	950	901	35	5	470	24-Ø34	512.5	346	407	1410	614	407	185	265	196	560	F10	662
900	36"	1115	1050	1001	37.5	5	510	28-Ø34	562.5	346	407	1530	675	451	185	265	196	615	F10	834
1000	40"	1230	1160	1112	40	5	550	28-Ø37	620	390	451	1712	748	512	230	333	232	670	F10	1172
1100	44"	1355	1270	1218	55	5	590	32-Ø37	682.5	390	451	1893	795	568	230	333	232	750	F10	1852
1200	48"	1455	1380	1328	45	5	630	32-Ø41	732.5	451	512	1971	865	568	230	368	232	800	F10	1714
1400	56"	1675	1590	1530	46	5	710	36-Ø44	842.5	507	568	2313	1011	660	315	453	360	920	F10	2570
1500	60"	1785	1700	1640	48	5	750	36-Ø44	897.5	507	568	2489	1112	660	315	453	360	980	F10	3140
1600	64"	1915	1820	1750	49	5	790	40-Ø50	962.5	507	568	2588	1161	660	315	453	360	1050	F10	3841

ISO 5210 UPPER FLANGE DIMENSIONS

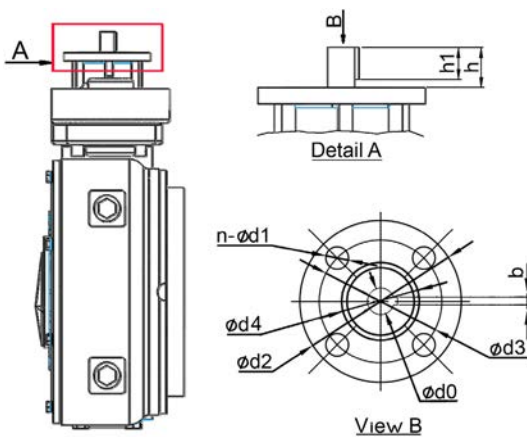

DN		ISO 5210								Number of turns	Torque * (Nm)
mm	inch	ISO flange	Ød0	n-Ød1	Ød2	Ød3	Ød4	h	bxh1		
200	8"	F10	20	4-Ø10	125	102	70	28	6X20	10	23
250	10"	F10	20	4-Ø10	125	102	70	28	6X20	10	36
300	12"	F10	20	4-Ø10	125	102	70	28	6X20	12	47
350	14"	F10	20	4-Ø10	125	102	70	28	6X20	12	65
400	16"	F10	20	4-Ø10	125	102	70	30	6X25	20	57
450	18"	F10	20	4-Ø10	125	102	70	30	6X25	20	72
500	20"	F10	20	4-Ø10	125	102	70	30	6X25	80	28
600	24"	F10	20	4-Ø10	125	102	70	30	6X25	64	53
700	28"	F10	20	4-Ø10	125	102	70	30	6X25	64	76
800	32"	F10	20	4-Ø10	125	102	70	30	6X25	96	73
900	36"	F10	20	4-Ø10	125	102	70	30	6X25	96	100
1000	40"	F10	20	4-Ø10	125	102	70	30	6X25	198,9	65
1100	44"	F10	20	4-Ø10	125	102	70	30	6X25	198,9	86
1200	48"	F10	20	4-Ø10	125	102	70	30	6X25	382,2	52
1400	56"	F10	20	4-Ø10	125	102	70	30	6X25	421,4	67
1500	60"	F10	20	4-Ø10	125	102	70	30	6X25	421,4	82
1600	60"	F10	20	4-Ø10	125	102	70	30	6X25	421,4	98

* Values without safety factor

Tecofi France

83 rue Marcel Mérieux - 69960 Corbas

Tél. +33 (0)4 72 79 05 79 - Fax. +33 (0)4 78 90 19 19

E-mail : sales@tecofi.fr - www.tecofi.fr



DOUBLE EXCENTRIC BUTTERFLY VALVE TYPE TECWAT

WORKING CONDITIONS

Maximum working pressure : 10 bar.
Maximum working temperature : + 80 °C.

FLOW FACTOR - Kv

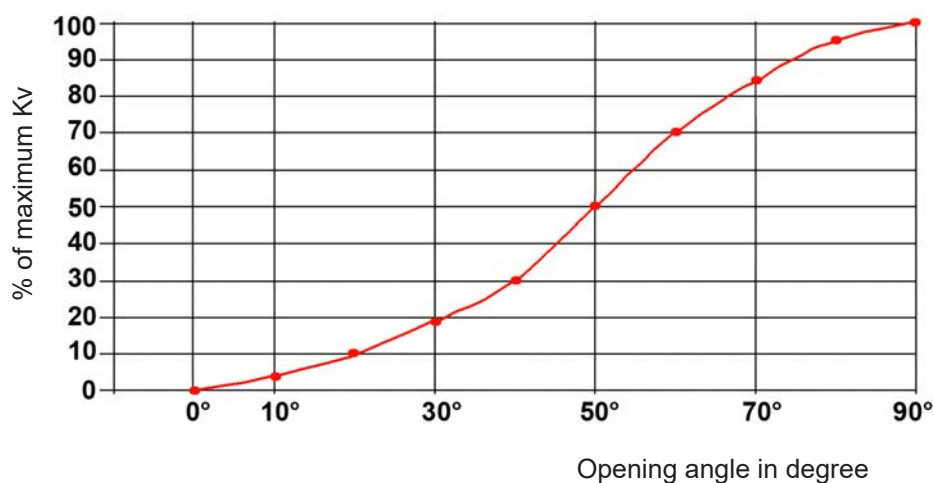

DN	mm	200	250	300	350	400	450	500	600	700	800	900	1000	1100	1200	1400	1600
	inch	8"	10"	12"	14"	16"	18"	20"	24"	28"	32"	36"	40"	44"	48"	56"	64"
Kvs		1880	3800	4950	8000	10900	14200	18250	28000	40500	55100	74000	93338	116213	142516	167310	264433

Values given for information

Tecofi France

83 rue Marcel Mérieux - 69960 Corbas
Tél. +33 (0)4 72 79 05 79 - Fax. +33 (0)4 78 90 19 19
E-mail : sales@tecofi.fr - www.tecofi.fr

