

# THROUGH CONDUIT KNIFE GATE VALVE WITH HANDWHEEL

## VGT 3400-00



### APPLICATION

General use : This gate is particularly adapted in paper mill, in the exit of pulp, for the recovery of the old paper where the product is mixed with numerous impurities (ex: staples).

### GENERAL CHARACTERISTICS

- Range : from DN 50 to DN 700.
- Bidirectional gate, with two seat gaskets.
- Longer body in two parts assembled by bolts.
- The gate is longer and its lower part rests out of the body, which requires a second system of gland packing.
- The gate contains a hole, which assures:
  - in opened position, a complete passage of the fluid without retention zone.
  - in closed position, the complete obturation.
- No retention zone: interesting in load or unloading of chemical device (dryer, reactor...).
- Valve tightness even in difficult conditions. No accumulation of product in the bottom of gate evacuation gorge.

### CONSTRUCTION

|      |      |                    |                         |   |
|------|------|--------------------|-------------------------|---|
| 19   | 1    | Nut                | Bronze                  |   |
| 18   | 1    | Friction washer    | Bronze                  |   |
| 17   | 1    | Stop screw         | Stainless steel         |   |
| 16   | 1    | Cap                | Plastic                 |   |
| 15   | 1    | Protection tube    | Steel                   |   |
| 14   | 1    | Handwheel          | Cast iron               | DIN : G25<br>ASTM : A48 class 40B<br>BS : 1452 Grade 250          |
| 13   | 1    | Greaser            | Stainless steel         |   |
| 12   | 1    | Nut support        | Zinc steel              |   |
| 11   | 1    | Position indicator | Stainless steel 304     |   |
| 10   | 1    | Stem               | Stainless steel         |   |
| 9*   | 2    | Support plate      | Steel + epoxy           |   |
| 8    | 2    | Packing gland      | Ductile iron            |   |
| 7    | 1    | Knife gate         | X5CrNi 18-10            | DIN : X5CrNi18 10<br>ASTM : A 182 AISI 304<br>BS : 1449-2 304 S15 |
| 6    | 2    | Gasket             | Nitril                  |   |
| 5    | 2    | Support ring       | Stainless steel 316     | DIN : X5CrNiMo18 10<br>ASTM : A 182 AISI 316<br>BS : 970 316 S16  |
| 4    | 2    | O-Ring             | Nitril                  |   |
| 3    | 4    | Packing            | Tallowed cotton         |   |
| 2    | 1    | Second body        | Cast iron<br>EN-GJL-250 | DIN : GG25<br>ASTM : A48 class 40B<br>BS : 1452 Grade 250         |
| 1    | 1    | Body               | Cast iron<br>EN-GJL-250 | DIN : GG25<br>ASTM : A48 class 40B<br>BS : 1452 Grade 250         |
| Pos. | Qty. | Description        | Material                |   |

### DIMENSIONS

| DN<br>mm | inch   | A   | B    | C     |      | D   | Ø V | H    | Ø K | n x M    | Weight<br>(Kg) |
|----------|--------|-----|------|-------|------|-----|-----|------|-----|----------|----------------|
|          |        |     |      | Mini. | Max. |     |     |      |     |          |                |
| 50       | 2"     | 40  | 283  | 162   | 221  | 150 | 200 | 348  | 125 | 4 x M16  | 13             |
| 65       | 2 1/2" | 40  | 308  | 190   | 264  | 168 | 200 | 388  | 145 | 4 x M16  | 15             |
| 80       | 3"     | 50  | 333  | 216   | 297  | 184 | 200 | 413  | 160 | 8 x M16  | 19             |
| 100      | 4"     | 50  | 378  | 245   | 354  | 205 | 200 | 488  | 180 | 8 x M16  | 23             |
| 125      | 5"     | 50  | 423  | 289   | 430  | 220 | 250 | 564  | 210 | 8 x M16  | 29             |
| 150      | 6"     | 60  | 474  | 330   | 530  | 240 | 250 | 635  | 240 | 8 x M20  | 38             |
| 200      | 8"     | 60  | 593  | 410   | 641  | 295 | 310 | 809  | 295 | 8 x M20  | 65             |
| 250      | 10"    | 70  | 685  | 486   | 772  | 355 | 310 | 946  | 350 | 12 x M20 | 100            |
| 300      | 12"    | 70  | 792  | 582   | 882  | 410 | 310 | 1118 | 400 | 12 x M20 | 122            |
| 350      | 14"    | 96  | 900  | 654   | 1043 | NC  | 500 | 1282 | 460 | 16 x M20 | 163            |
| 400      | 16"    | 100 | 978  | 731   | 1168 | NC  | 500 | 1441 | 515 | 16 x M24 | 235            |
| 450      | 18"    | 106 | 1105 | 809   | 1296 | NC  | 500 | 1587 | 565 | 20 x M24 | 368            |
| 500      | 20"    | 110 | 1215 | 916   | 1454 | NC  | 500 | 1809 | 620 | 20 x M24 | 471            |
| 600      | 24"    | 110 | 1418 | 1066  | 1706 | NC  | 500 | 2060 | 725 | 20 x M27 | 532            |
| 700      | 28"    | 110 | 1640 | 1236  | 1981 | NC  | 800 | 2372 | 840 | 24 x M27 | 936            |



Standard assembling



Strengthened assembling

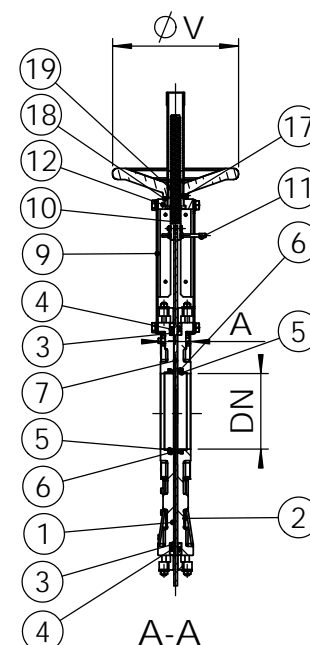
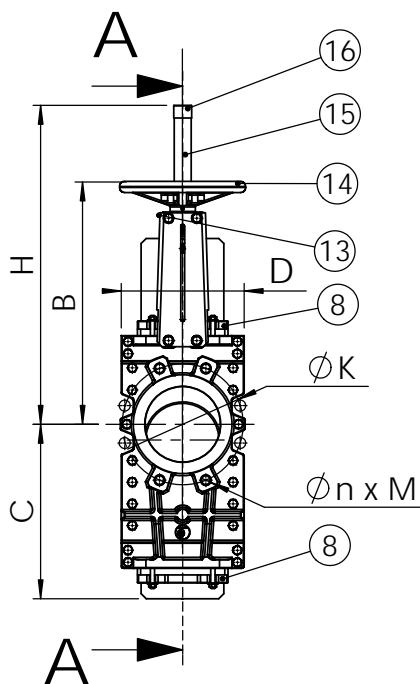

\* Pre-sharped parts up to DN 300.

### WORKING CONDITIONS

Maximum working pressure :

- DN 50-250 : 10 bar
- DN 300-400 : 6 bar
- DN 450-600 : 3.5 bar
- DN 700 : 2.5 bar

Maximum temperature : +80 °C

### STANDARDS

Manufacture according to the requirements of the European directive 97/23/CE «Equipments under pressure» : modulate H.

Test procedures are established according to standards EN 12266-1, DIN 3230, BS 5154 and ISO 5208.

Raised face in accordance to standard EN 1092-2.

Face to face according to standard TECOFI.

Wafer type ISO PN10 according to standard EN 1092-2.

**TECOFI France** - 83, Rue Marcel Mérieux 69960 Corbas - FRANCE  
Tél. +33 (0) 4 72 79 05 79 - Fax +33 (0) 4 78 90 19 19 / +33 (0) 4 72 79 05 70  
Adresses e-mail : sales@tecofi.fr ; tecofi@tecofi.fr / Site web : [www.tecofi.fr](http://www.tecofi.fr)