

Ref. : RMD3201-000.pas

Rev. : D

Date : 18/01/2012

Page : 1/1

FLANGED DIAPHRAGM VALVE NON RISING HANDWHEEL STRAIGHT THROUGH TYPE

RMD3201-000



Tecofi
VALVE DESIGNER - FRANCE

PRODUCT REFERENCE

REFERENCES	Type
<input type="checkbox"/> RMD3201-000	Body lining ebonite
<input type="checkbox"/> RMD3201F-000	Cast iron body

APPLICATION

General use : water treatment plants, fertilizer & petrochemicals industries, chemical industries, refineries, thermal power stations, etc.

GENERAL CHARACTERISTICS

Design according to standard EN13397
Range : DN 15 up to DN 300
Straight through type.
Low head loss.
Diaphragm replaceable without removing the valve.

CONSTRUCTION

Rep.	Description	Material
	Lubricator**	
8	Thrust bearing*	
7	Stem	Stainless steel 410
6	Stem bush	Cast iron GS
5	Handwheel	Cast iron
4	Compressor	Cast iron
3	Bonnet	Cast iron
2	Diaphragm	See table
1	Body	Cast iron or Cast iron lining ebonite

*For DN80 to 300
**For DN125 to 300

DIMENSIONS

DN	A	B	Ø C	Ø D	F	PMS	Weight (kg)
15	108	88	70	95	12,0	10,5 bar	2,4
20	117	88		105	12,0		2,8
25	127	111	100	115	12,0		4,2
32	146	111		140	12,0		4,5
40	159	111		150	15,0		5,5
50	190	144	140	165	17,5	10	
65	216	174	180	185	18,0	15	
80	254	200	225	200	19,0	25	
100	305	236		230	23,8	32	
125	356	267	310	254	23,8	7 bar	55
150	406	429	368	285	20,0	5,25 bar	85
200	521	414		343	22,0		144
250	635	540	587	406	24,0		188
300	749	635		483	24,0		330

WORKING CONDITIONS

Ref.	Diaphragm materials	Application	Hardness	UTS (kg/cm ²)	Temp.
BU	IIR (Type Butyl®)	Steam sterilisation	60 - 70	100	-25°C / 120°C
AL	White IIR (Type Butyl®)	Food and pharmaceuticals	55- 65	80	-25°C / 105°C
EP	Ethylene propylene	Radio active materials	65 -75	890	-30°C / 150°C
CN	Natural rubber	Mildly acid resistant	65 -75	170	-30°C / 80°C
NE	CR (Type neoprene®)	Diluted acid resistant	60 - 70	120	-25°C / 95°C
HY	CSM (Type Hypalon®)	Acid resistant	60 - 70	80	-15°C / 100°C
VI	FPM (Type Viton®)	Aromatics chlorine	70 - 80	70	-5°C / 150°C
PF	PTFE	All chemicals and food application	-	70	-30°C / 175°C
SI	Silicone Rubber	High temperatures resistance	55-65	70	-100°C / 250°C
NI	Nitrile rubber (BUNA-N)	Oils and fats	65 - 75	120	-10°C / 90°C

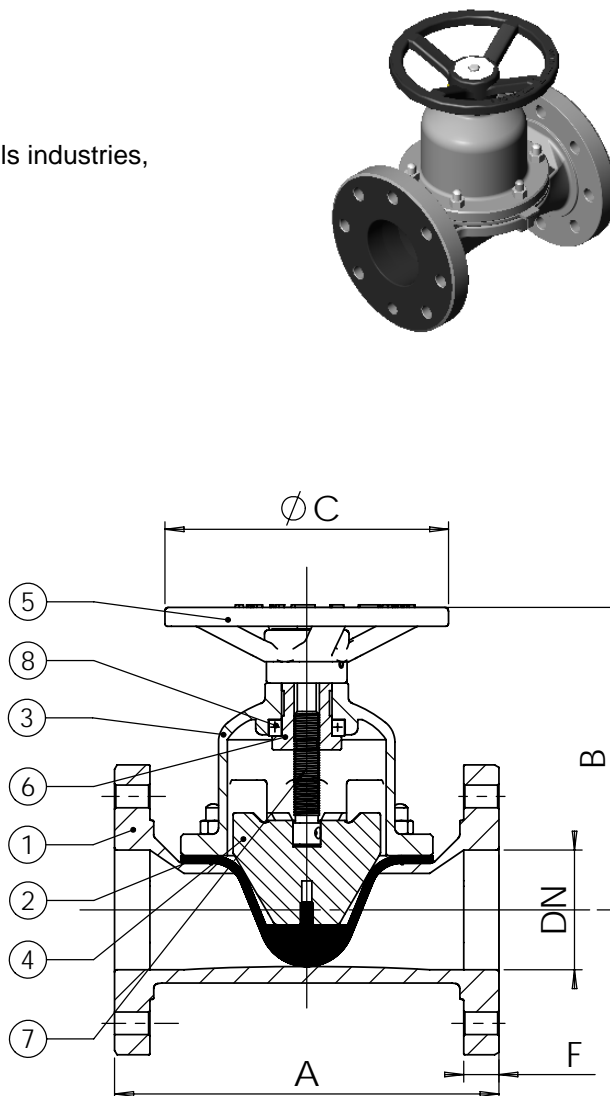

STANDARDS

Pressure test according to standards EN 12266-1, BS 6755-1:
Body : 1,5 x PS bar.
Seat : 1,1 x PS bar.

Face to face according to standard EN 558-1.
Valves flanged can be drilled to suit ASME / BS / DIN / JIS.

TECOFI France - 83, Rue Marcel Mérioux 69960 Corbas - FRANCE
Tél. +33 (0) 4 72 79 05 79 - Fax +33 (0) 4 78 90 19 19 / +33 (0) 4 72 79 05 70
Adresses e-mail : sales@tecofi.fr ; tecofi@tecofi.fr / Site web : www.tecofi.fr