

FLANGED PN10 DOUBLE CHAMBER AIR VALVE

TECHNICAL PASSPORT

DOUBLE CHAMBER / TRIPLE FUNCTION AIR RELEASE FLANGED PN10

PVT4200

APPLICATION

The double chamber /triple function air valve is intended for use in clear water supply systems.

It provides the following functions:

1. Disposal of large volumes of air during fill of the pipes of system.
2. The supply of large amounts of air to the system closure during purging of the piping.
3. Rejection of pressurized air pockets during operation.



Fluids : clear water, potable water.



GENERAL CHARACTERISTICS

Range : from DN40 to DN500.

Body consisting of a chambers containing floats.

Large discharge and intake capacity.

Body coating : epoxy powder paint bonded by electrostatic fusion

(RAL 5005, 300 microns).

STANDARDS

Connection	Flange assembling PN10 according to EN1092-2, ISO 7005/2 , BS4504 PN10.
------------	---

PRODUCT APPROVALS

ERC

Tecofi France

83 rue Marcel Mérieux - 69960 Corbas
Tél. +33 (0)4 72 79 05 79 - Fax. +33 (0)4 78 90 19 19
E-mail : sales@tecofi.fr - www.tecofi.fr



FLANGED PN10 DOUBLE CHAMBER AIR VALVE

TECHNICAL PASSPORT

PVT4200

CONSTRUCTION

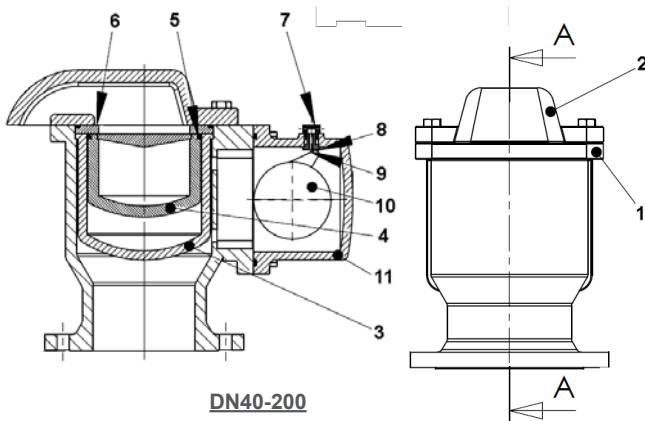

Pos.	Description	Material
1	Body	Ductile iron GGG40
2	Cover	Ductile iron GGG40
3	Cage	Polyamid 6
4	Ball	Polyethylene
5	O-ring	NBR
6	Disc	Brass
7	Orifice cover	Stainless steel 304
8	Support	Brass
9	Sealing gasket	NBR
10	Small ball	Polyethylene
11	Box	Ductile iron GGG40

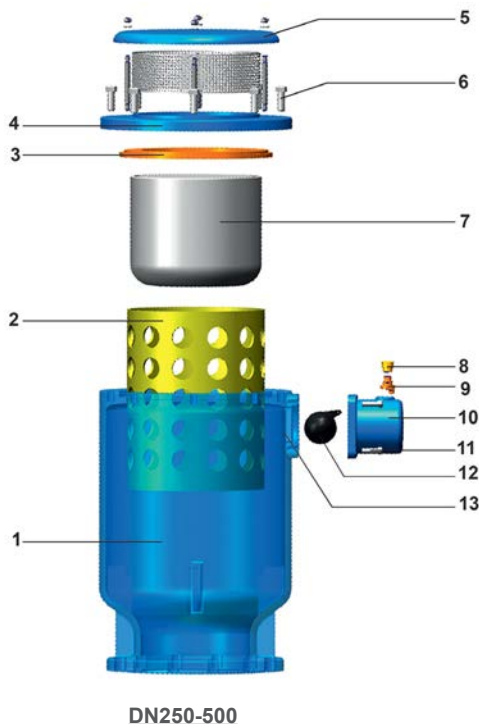

Pos.	Description	Material
1	Body	Ductile iron GGG40
2	Cage	Polyamid 6
3	Disc	Brass
4	Cover	Ductile iron GGG40
5	Upper cover	Ductile iron GGG40
6	Screw	Galvanized steel 8.8
7	Big ball	Polyethylene
8	Orifice cover	Brass
9	Orifice body	Brass
10	Box	Ductile iron GGG40
11	Screw	Galvanized steel 8.8
12	Ball	Polyethylene
13	Sealing gasket	NBR

The photographs and technical art works are not contractual. The specifications of the presented products are open to modifications without previous advice.

Tecofi France

83 rue Marcel Mérieux - 69960 Corbas
 Tél. +33 (0)4 72 79 05 79 - Fax. +33 (0)4 78 90 19 19
 E-mail : sales@tecofi.fr - www.tecofi.fr



FLANGED PN10 DOUBLE CHAMBER AIR VALVE

TECHNICAL PASSPORT

PVT4200

DIMENSIONS

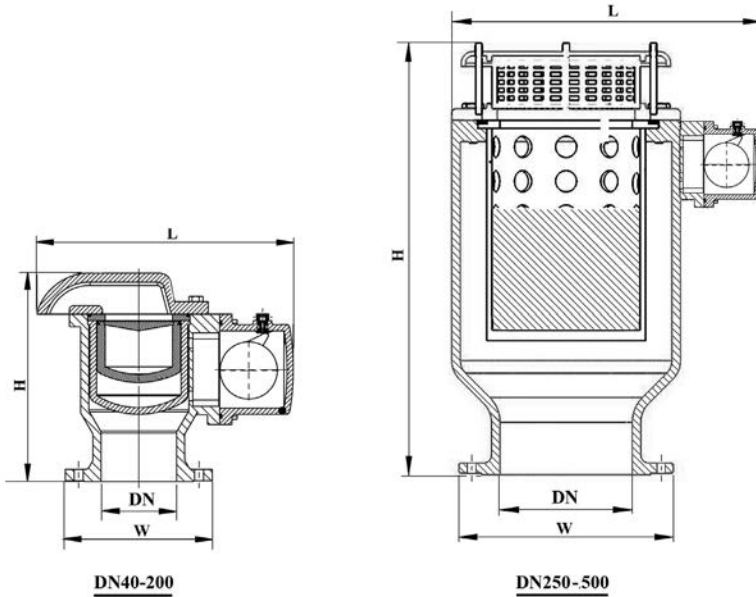

DN		L	H	W	Poids (kg)
mm	inch				
40	1 1/2"	325	255	150	17
50	2"	325	260	165	17
65	2 1/2"	325	260	185	20.1
80	3"	325	260	200	20.4
100	4"	370	320	220	31.2
125	5"	370	320	250	32
150	6"	370	320	285	34
200	8"	370	450	340	64
250	10"	580	810	395	181
300	12"	700	975	525	195
350	14"	880	1065	615	420
400	16"	910	1220	700	835
500	20"	1135	1525	880	1035

AIR INFLOW AND OUTFLOW

Air outflow

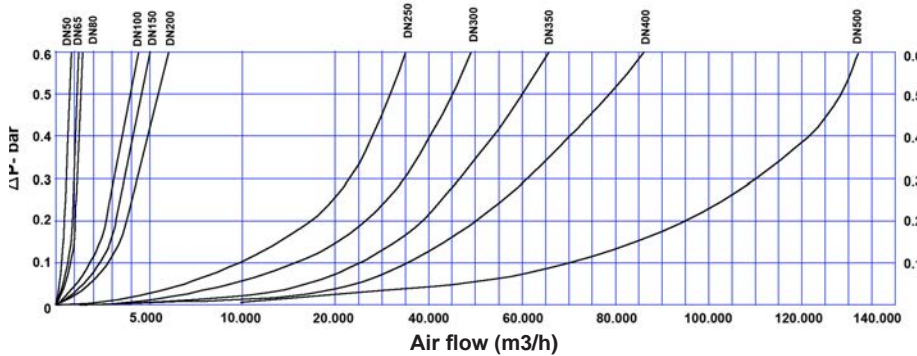

Air inflow

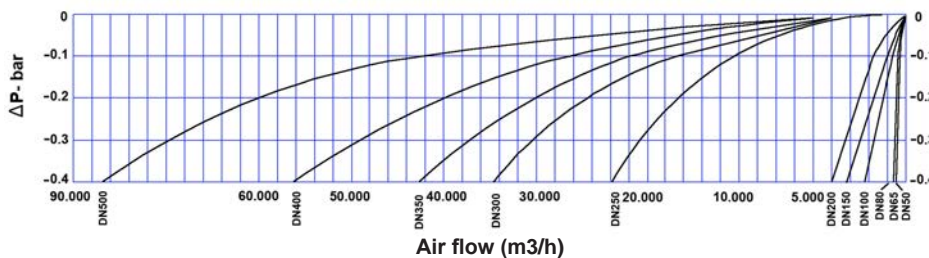

WORKING CONDITIONS

Maximum working pressure : 10 bar
 Minimum working pressure : 0.2 bar
 Maximum working temperature : -10°C / 80°C

Tecofi France

83 rue Marcel Mérieux - 69960 Corbas
 Tél. +33 (0)4 72 79 05 79 - Fax. +33 (0)4 78 90 19 19
 E-mail : sales@tecofi.fr - www.tecofi.fr

