

DISMANTLING JOINT

TECHNICAL PASSPORT

PN25 DISMANTLING JOINT

JT4253-EA

APPLICATION

Dismantling joints mounted with flanged shut-off valves facilitate their assembly and disassembly by compensating for the axial movement of the piping.



Fluids : water, drinking water, compatible fluids, etc.

GENERAL CHARACTERISTICS

Range : from DN100 to DN900.
Connection : PN25 according to EN 1092-2.
GEOMET 500® steel tie rods and nuts.
Epoxy coating.
Adjustment of +/-25 mm.

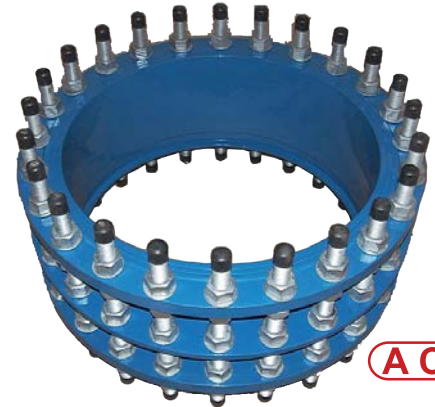

Epoxy coated body according to EN 14901
RAL 5015, 250 µm thickness

CONSTRUCTION

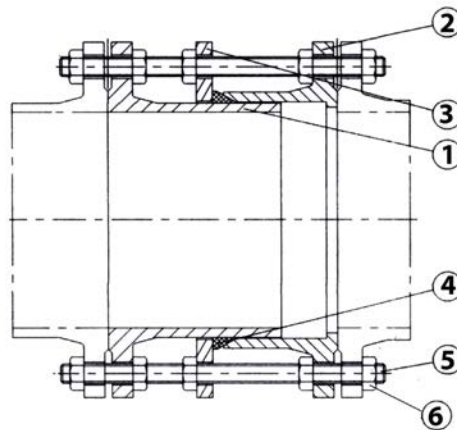

Pos.	Description	Material	Equivalence		
			DIN	ASTM	BS
1	Flanged pipe-long	Ductile iron EN-GJS-500-7	GGG50	A536 70-50-05	BS 500/7
2	Flanged pipe-short	Ductile iron EN-GJS-500-7	GGG50	A536 70-50-05	BS 500/7
3	Retaining flange	Ductile iron EN-GJS-500-7	GGG50	A536 70-50-05	BS 500/7
4	Sealing ring	ACS EPDM (WRAS QUALITY)			
5	Stud bolt	Steel 4.8	GEOMET 500®		
6	Nut	Steel	GEOMET 500®		

PRODUCT APPROVALS

ERC **ACS** n° 21 ACC LY 758

Tecofi France

83 rue Marcel Mérieux - 69960 Corbas
Tél. +33 (0)4 72 79 05 79 - Fax. +33 (0)4 78 90 19 19
E-mail : sales@tecofi.fr - www.tecofi.fr



DISMANTLING JOINT

TECHNICAL PASSPORT

JT4253-EA

DIMENSIONS

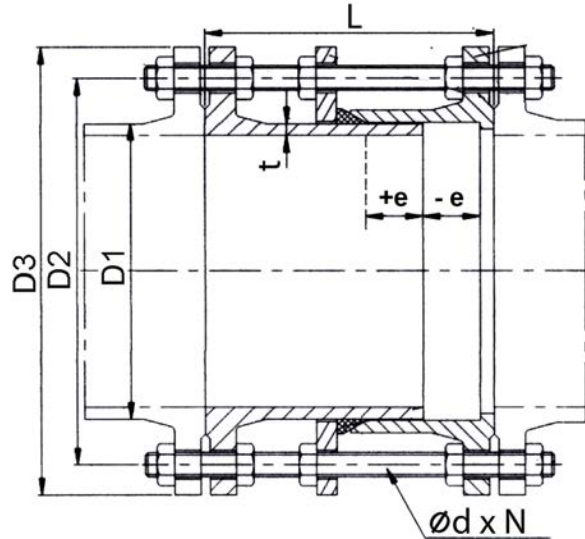

DN		e	L	$\varnothing D1$	$\varnothing D2$	$\varnothing D3$	N	d	t	Weight (kg)
mm	inch									
100	4"	25	195	118	190	235	8	23	7.2	22
125	5"	25	195	144	220	270	8	28	7.2	30
150	6"	25	205	170	250	300	8	28	7.8	35
200	8"	25	205	222	310	360	12	28	8.4	51
250	10"	25	225	274	370	425	12	31	9	74
300	12"	25	225	326	430	485	16	31	9.6	91
350	14"	25	235	378	490	555	16	34	10.2	110
400	16"	25	255	429	550	620	16	37	10.8	178
450	18"	25	255	480	600	670	20	37	11.4	226
500	20"	25	275	532	660	730	20	37	12	233
600	24"	25	295	635	770	845	20	40	13.2	312
700	28"	25	315	738	875	960	24	43	14.4	408
800	32"	25	335	842	990	1085	24	49	15.6	553
900	36"	25	335	945	1090	1185	28	49	16.8	700

WORKING CONDITIONS

Maximum working pressure: 25 bar

Maximum working temperature: +4°C / +110°C

Tecofi France

83 rue Marcel Mérieux - 69960 Corbas

Tél. +33 (0)4 72 79 05 79 - Fax. +33 (0)4 78 90 19 19

E-mail : sales@tecofi.fr - www.tecofi.fr

