

Ref. : FI5843SW

Rev. : Initial

Date : 19/01/2015

Page : 1/1

FORGED CARBON STEEL "Y" STRAINER

FI5843SW



APPLICATION

General use: Petroleum industry, steam, high pressure.

GENERAL CHARACTERISTICS

With draining cap.
Removable stainless steel filter.
Respect the flow direction indicated by the arrow.
Horizontal or vertical position with descendant fluid.
Mesh 8/10° mm (800 μ).
800 lbs type.

CONSTRUCTION

6	Screw*	Steel ASTM A193 B7
5	Drain plug	Steel ASTM A105 N
4	Gasket	Stainless steel 316 + graphite
3	Screen	Stainless steel ASTM A240 316L
2	Bonnet	Steel ASTM A105 N
1	Body	Steel ASTM A105 N
Pos.	Description	Material

*Only for DN50

DIMENSIONS

DN		L	H	H1	H2	ØD	B	G (NPT)	E	ØF	Weight (kg)
mm	inch										
8	1/4"	90	60	41	105	18	-	1/4"	10	14.2	0.85
10	3/8"	90	60	41	105	18	-	1/4"	13	17.6	0.78
15	1/2"	90	60	41	105	18	-	1/4"	14	21.72	0.73
20	3/4"	110	75	60	140	22	-	1/4"	16	27.05	1.22
25	1"	130	93	75	155	28	-	1/4"	20	33.78	1.88
32	1 1/4"	160	120	100.5	195	41.5	-	1/4"	22	42.54	4.75
40	1 1/2"	160	120	100.5	195	41.5	-	1/4"	22	48.64	4.45
50	2"	160	145	100.5	205	49.5	90x90	1/2"	26	61.11	6.5

WORKING CONDITIONS

Maximum temperature: -29°C / 425°C
Maximum pressure: 138 bar

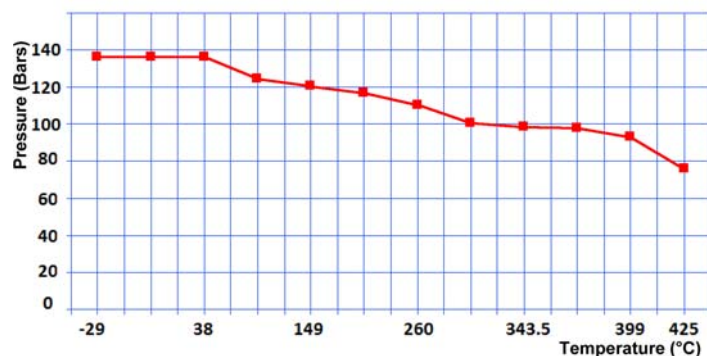

STANDARDS

Fabrication according to ISO 9001 :2008.
DIRECTIVE CE FI Ø i ØVO.
Risk category III Module H.
Designing according to ASME B16.34.
Tests according to API 598.
ATEX Group II Category 2 G/2D Zone 1 & 21 Zone 2 & 22.
Socket welding (SW) connection.



DN8-40

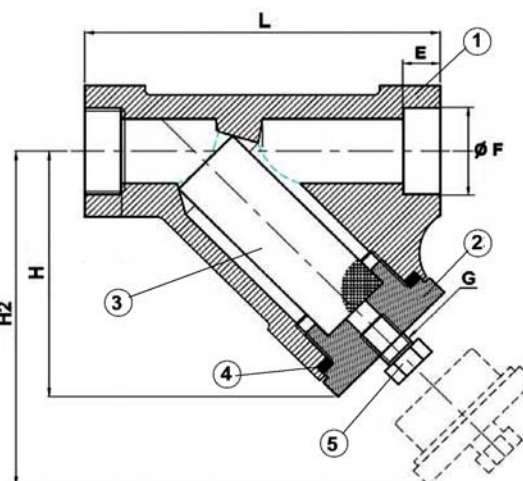

DN50

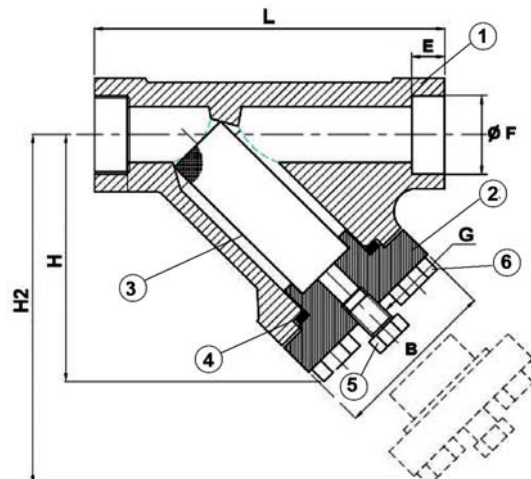

HEAD LOSS GRAPH

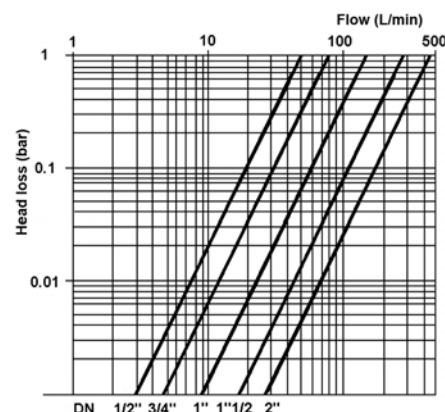

TECOFI France - 83, Rue Marcel Mérieux 69960 Corbas - FRANCE
Tél. +33 (0) 4 72 79 05 79 - Fax +33 (0) 4 78 90 19 19 / +33 (0) 4 72 79 05 70
Adresses e-mail : sales@tecofi.fr ; tecofi@tecofi.fr / Site web : www.tecofi.fr