

Ref. : DI 7350.pas

Rev. : J

Date : 13/01/2016

Page : 1/1

SOCKET ENDS STAINLESS STEEL EXPANSION JOINT

DI 7350



APPLICATION

Expansion joint.

GENERAL CHARACTERISTICS

Stainless steel bellow
BW connection.

Movement :

- 25 mm
- 50 mm
- 75 mm on request

CONSTRUCTION

3	1	Guide sleeve	Steel
2	2	Socket	Steel
1	1	Bellow	Stainless steel
Pos.	Qty.	Description	Material

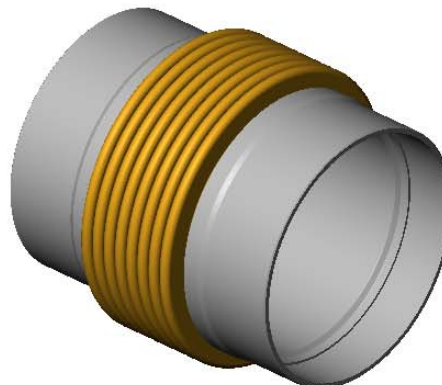

DIMENSIONS

DN		Axial movement	Spring rate	Cross section	L	Weight (kg)
mm	inch					
15	1/2"	25	34	5	200	0,3
15	1/2"	50	17	5	350	0,5
20	3/4"	25	27	8	210	0,4
20	3/4"	50	14	8	340	0,6
25	1"	25	36	11	200	0,5
25	1"	50	18	11	330	0,8
32	1" 1/4	25	31	18	220	0,7
32	1" 1/4	50	15	18	350	1,1
40	1" 1/2	25	39	22	220	0,8
40	1" 1/2	50	19	22	340	1,3
50	2"	25	76	37	250	1,4
50	2"	50	38	37	380	2,1
65	2" 1/2	25	62	53	260	2,1
65	2" 1/2	50	31	53	380	2,9
80	3"	25	59	77	280	3
80	3"	50	29	77	370	4
100	4"	25	313	124	260	4
100	4"	50	169	124	360	6
125	5"	25	744	183	260	6
125	5"	50	401	183	360	8
150	6"	25	996	259	270	8
150	6"	50	536	259	380	11
200	8"	25	745	433	280	12
200	8"	50	474	433	380	17
250	10"	25	1093	657	250	15
250	10"	50	497	657	390	23
300	12"	25	1105	913	260	19
300	12"	50	502	913	400	28
350	14"	25	912	1102	260	21
350	14"	50	415	1102	410	32
400	16"	25	1687	1446	290	30
400	16"	50	1205	1446	380	39
500	18"	25	1858	2220	290	38
500	18"	50	1327	2220	380	49
600	20"	25	1980	3159	290	46
600	20"	50	1414	3159	380	60

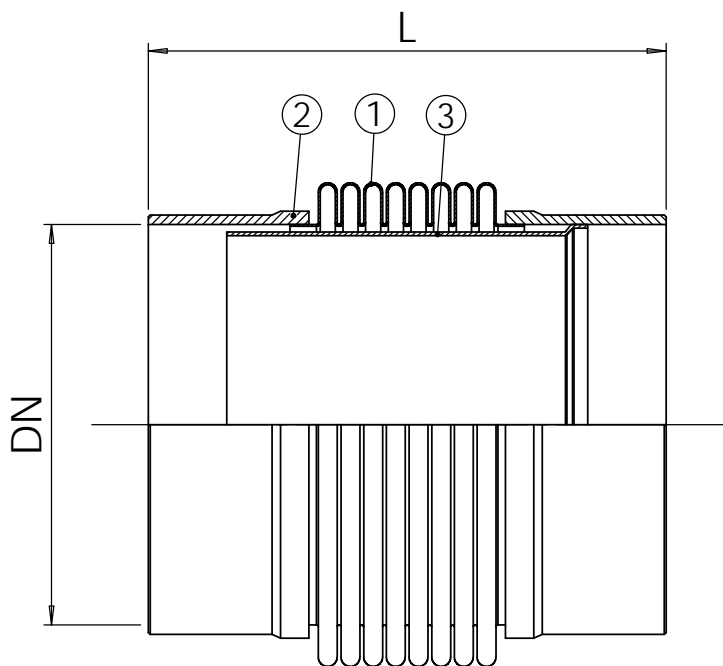

WORKING CONDITIONS

Maximum working pressure :

- 25 bar (DN 15-65).
- 16 bar (DN 80-200).
- 10 bar (DN 250-600).

Pressure test according to standards

EN 12266-1, DIN 3230, BS 6755 and ISO 5208.

Maximum temperature : + 400°C.

TECOFI France - 83, Rue Marcel Mérieux 69960 Corbas - FRANCE
Tél. +33 (0) 4 72 79 05 79 - Fax +33 (0) 4 78 90 19 19 / +33 (0) 4 72 79 05 70
Adresses e-mail : sales@tecofi.fr ; tecofi@tecofi.fr / Site web : www.tecofi.fr