

RUBBER EXPANSION JOINT

TECHNICAL PASSPORT

RUBBER EXPANSION JOINT WITH SWIVEL FLANGE

DI 724016N

APPLICATION

- Reduction of mechanical and thermal stress on pipes and related systems : pumps, compressors, motors.
- Absorption of vibrations and noise
- Compensation of axial, lateral and angular movements
- Correction of misalignment of the piping.



Fluids : hot and cold water

GENERAL CHARACTERISTICS

- Range** : from DN200 to DN600.
Universal expansion joint consisting of :
- EPDM elastomer bellows
 - Swivel flanges made of carbon steel zinc plated.
 - Identical face to face for all diameters.



CONSTRUCTION

Pos.	Quantity	Description	Material
1	2	Flange	Zinc plated steel
2	2	Reinforced wire	Steel
3	1	Internal bellow	EPDM
4	1	External bellow	EPDM
5	1	Reinforcement	Nylon tyre cord

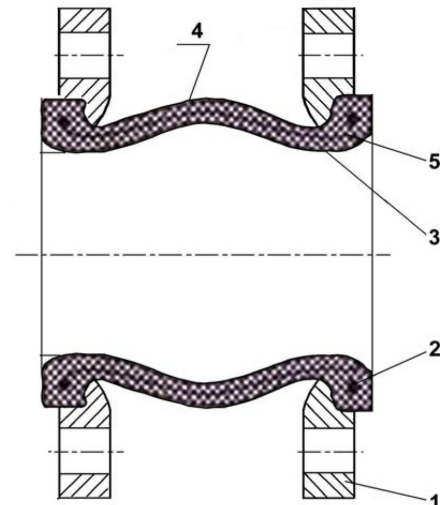

STANDARDS

Connection	Flange connection according to standard EN 1092-1 : PN16
Tests	Pressure test according to standards EN12266-1, DIN 3230, BS 5154 and ISO 5208:

PRODUCT APPROVALS



Tecofi France

83 rue Marcel Mérieux - 69960 Corbas
Tél. +33 (0)4 72 79 05 79 - Fax. +33 (0)4 78 90 19 19
E-mail : sales@tecofi.fr - www.tecofi.fr



RUBBER EXPANSION JOINT

TECHNICAL PASSPORT

RUBBER EXPANSION JOINT WITH SWIVEL FLANGE

DI 724016N

DIMENSIONS

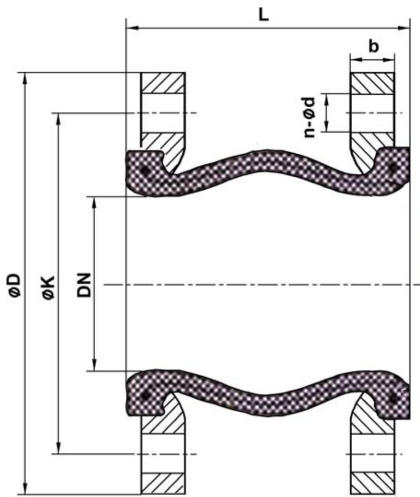

DN		L	øK	n x ød	øD	b	Lc	Le	Li	A°	Weight (kg)
mm	inch										
200	8"	205	295	12 x ø23	340	21	20	12	16	15	17.5
250	10"	240	355	12 x ø27	405	23	30	14	25	8	24.9
300	12"	260	410	12 x ø27	460	25	30	14	25	8	30.8
350	14"	265	470	16 x ø27	520	25	30	14	25	8	41.6
400	16"	265	525	16 x ø30	580	27	30	14	25	8	46.5
450	18"	265	585	20 x ø30	640	29	30	14	25	8	58.8
500	20"	265	650	20 x ø34	715	29	30	14	25	8	62.3
600	24"	265	770	20 x ø36	840	29	30	14	25	8	73.1

⚠ In case of high pressure, we recommend installing tie rods from DN350 to DN600.

WORKING CONDITIONS

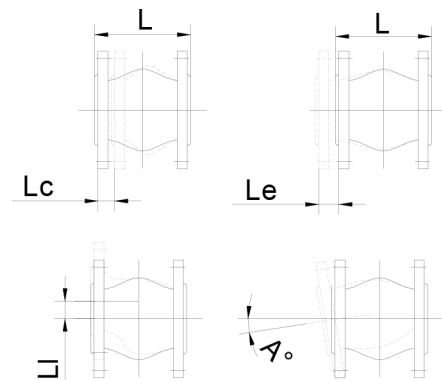
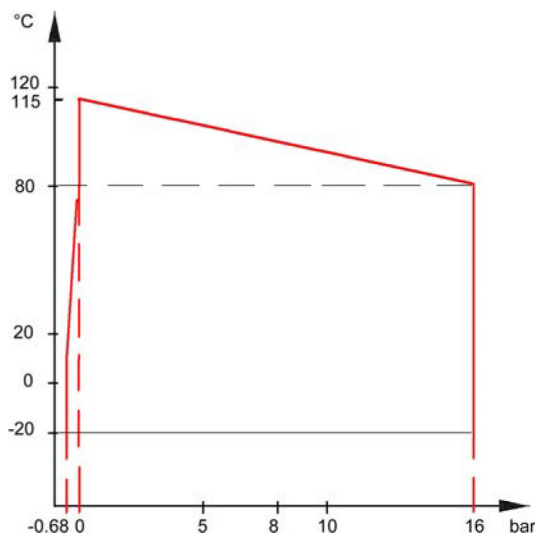

Lc : Axial compression
 Le : Axial elongation
 Li : Lateral movement
 A° : Angle movement

Tecofi France

83 rue Marcel Mérieux - 69960 Corbas
 Tél. +33 (0)4 72 79 05 79 - Fax. +33 (0)4 78 90 19 19
 E-mail : sales@tecofi.fr - www.tecofi.fr

