

STRAINER FOR CHECK VALVE

TECHNICAL PASSPORT

STRAINER FOR FLANGED AXIAL CHECK VALVE STAINLESS STEEL BODY

CR 6200B

APPLICATION

Area of use: Water distribution and watering.



Fluids: water and compatible fluids.

GENERAL CHARACTERISTICS

- Range : DN50 to DN300.
- Easy cleaning and disassembling.
- Flanged connection PN10 and/or PN16 according to EN 1092.

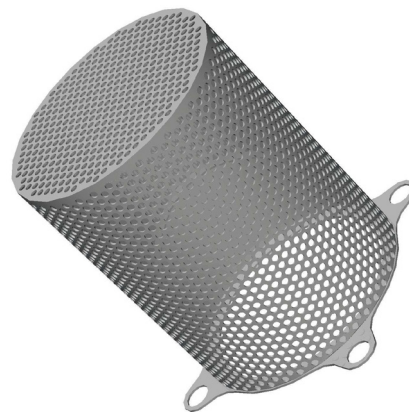

CONSTRUCTION

Pos.	Description	Material
1	Body	Stainless steel 316

DIMENSIONS

DN		A	B	C		n-ØD		E	F	G	H	Perforated sheets
mm	inch			PN10	PN16	PN10	PN16					
50	2"	65	70	125		4-Ø18		150	105	130	2	R 6 T 8.5 Thickness : 1
65	2"1/4	85	95	145		4-Ø18		170	105	150	2	
80	3"	90	110	160		4-Ø18		185	120	160	2	
100	4"	110	130	180		4-Ø18		205	140	200	2	
125	5"	135	160	210		4-Ø18		235	170	250	2	
150	6"	170	195	240		4-Ø22		270	200	250	2	R 6 T 8.5 Thickness : 1.5
200	8"	222	250	295	295	4-Ø22	4-Ø22	325	255	330	2	
250	10"	260	300	350	355	6-Ø22	6-Ø22	380	305	460	2	
300	12"	305	350	400	410	6-Ø22	6-Ø26	430	355	500	2	

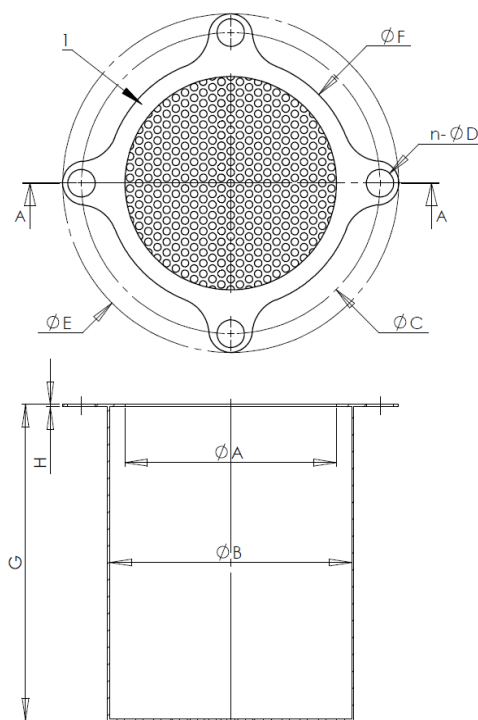

WORKING CONDITIONS

Maximum working pressure : 16 bar

Maximum working temperature: -20°C /+200°C.

Tecofi France

83 rue Marcel Mérieux - 69960 Corbas
Tél. +33 (0)4 72 79 05 79 - Fax. +33 (0)4 78 90 19 19
E-mail : sales@tecofi.fr - www.tecofi.fr



The photographs and technical art works are not contractual. The specifications of the presented products are open to modifications without previous advice