

Ref. : CB 5442.pas

Rev. : Initial

Date : 11/07/2017

Page : 1/1

WAFER TYPE DUAL PLATE CHECK VALVE ASA 150

CB 5442



APPLICATION

General uses: pumping, water supply, air conditioning installation.

GENERAL CHARACTERISTICS

Design in accordance with standard NF EN 12334 and NF EN 14341.

Range: From DN 600 to DN 800.

Mounting between flanges.

Working positions: horizontal and vertical ascending.

Mounting in accordance with many standards connections.

Low head loss.

Stainless steel spring technology to avoid fluid hammer.



CONSTRUCTION

6	1	Washer	Stainless steel AISI-304
5	1	Shaft	Stainless steel AISI-304
4	1	Spring	Stainless steel AISI-302
3	1	Gasket	NBR
2	2	Plate	Steel WCB A216
1	1	Body	Steel WCB A216
Pos.	Q-ty	Description	Material

DIMENSIONS

DN		L	Ø A	Ø D	Kv	Minimum Working pressure (mbar)	Weight (kg)
mm	inch						
600	24"	178	580	717	23076	0.79	193
700	28"	229	670	832	32136	0.76	328
800	32"	241	775	938	42735	0.7	415

WORKING CONDITIONS

Maximum working pressure : 20 bar.

Maximum temperature : +100°C.

Pressure test according to standards

EN 12266-1, DIN 3230, BS 6755 and ISO 5208 :

Body : 1.5xWP in bar.

Seat : 1.1xWP in bar.

STANDARDS

Face to face according to standards NF EN 558-1

serie 16 tab11 and DIN 3202 .

Mounting between flanges ASA 150 according to

EN 14341 / ASME B16.34.

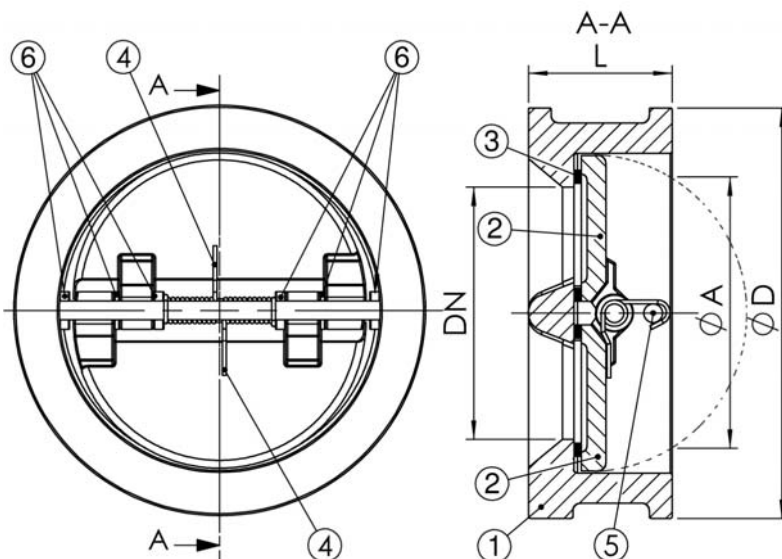

Horizontal

For assembling in horizontal position, check axis as to be placed in vertical position

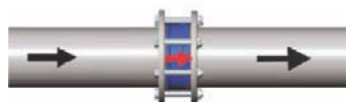

Vertical

To be assembled in vertical position the opening direction of the plates has to be in accordance with the direction of the fluid.



Fluide ascendant