

THREADED BALL VALVE

TECHNICAL PASSPORT

**3 PIECES STAINLESS STEEL
BUTT WELDING BALL VALVE
FULL BORE**

BS 6375BW

APPLICATION

Area of use: Chemical and pharmaceutical industries petro-chemical industries, hydraulic installations.



Fluids: water, steam, oil, compatible liquid products.



GENERAL CHARACTERISTICS

Range: DN 1/4" to DN 4".

- Full bore, anti blow-out stem.
- Gland packing with elastic washer for backlash adjustment.
- With tie rods connecting the ends to the body.
- PTFE food seal in accordance with standard FDA n° 21 CFR 177.1550

AGREMENTS ET NORMES

Design	Meets the requirements of European Directive 2014/68/UE: «Equipment under pressure» modulate H.
Connection	Butt welding (BW) according to NFA 49115
Test	Pressure tests according to EN12266-1, DIN 3230, BS 5154 and ISO 5208. - Body : PS x 1.5 (bar) - Seat : PS x 1.1 (bar)

PRODUCT APPROVALS



THREADED BALL VALVE

TECHNICAL PASSPORT

BS 6375BW

CONSTRUCTION

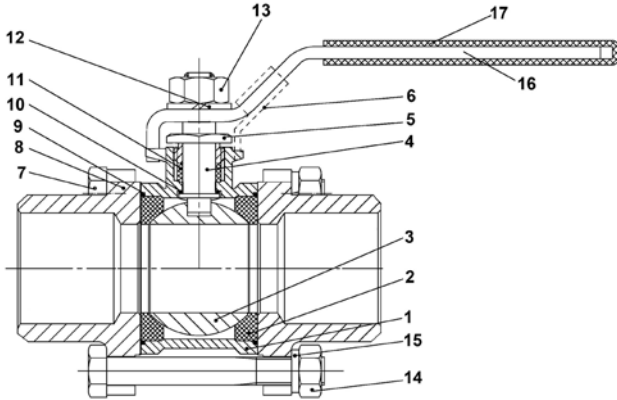

Pos.	Q-ty	Description	Material
1	1	Body	Stainless steel CF8M
2	2	Seat	PTFE
3	1	Ball	Stainless steel 316
4	1	Stem	Stainless steel 316
5	1	Packing nut	Stainless steel 304
6	1	Locking device	Stainless steel 304
7	4-6	Screw	Stainless steel 304
8	2	End cap	Stainless steel CF8M
9	2	Gasket	PTFE
10	1	Thrust washer	PTFE
11	1	Packing	PTFE
12	1	Stem washer	Stainless steel 304
13	1	Stem nut	Stainless steel 304
14	4-6	Nut	Stainless steel 304
15	4-6	Spring washer	Stainless steel 304
16	1	Handle	Stainless steel 304
17	1	Sleeve	Plastic

DIMENSIONS

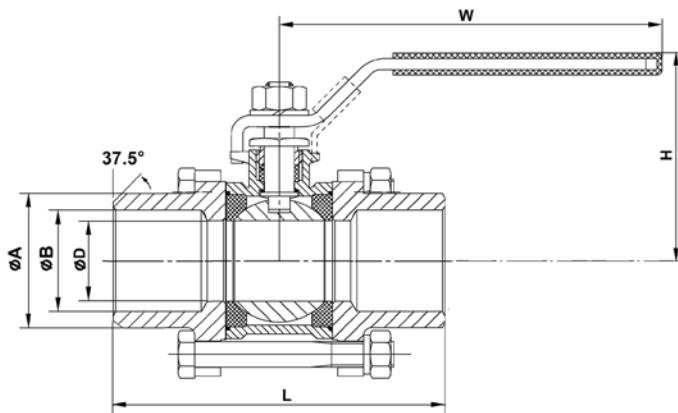

DN		L	H	ØD	ØB	ØA	W	Weight (kg)
mm	inch							
8	1/4"	60	52	8.8	8.8	13.5	105	0.280
10	3/8"	60	52	11	12.5	17.2	105	0.265
15	1/2"	70	55	15	16	21.3	105	0.440
20	3/4"	85	63	20	21.6	26.9	105	0.605
25	1"	95	70	25	27.2	33.7	137	0.820
32	1 1/4"	110	76	32	35.9	42.4	137	1.465
40	1 1/2"	120	89	38	41.8	48.3	182	1.795
50	2"	142	97	50	53	60.3	182	2.860
65	2 1/2"	166	143	64	68.8	76.1	260	5.640
80	3"	182	152	76	80.8	88.9	260	8.240
100	4"	227	187	94	105.3	114.3	403	17.120

WORKING CONDITIONS

Maximum working pressure : 1/4" - 2" : 63 bar
2 1/2" - 4" : 50 bar

Maximum working temperature: -20°C /+200°C.

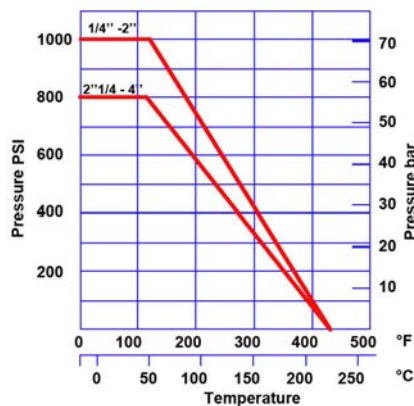

Tecofi France

83 rue Marcel Mérieux - 69960 Corbas
Tél. +33 (0)4 72 79 05 79 - Fax. +33 (0)4 78 90 19 19
E-mail : sales@tecofi.fr - www.tecofi.fr

