

Ref. : BS5163NPT

Rev. : Initial

Date : 20/01/2015

Page : 1/1

FORGED STEEL 3 PIECES BALL VALVE 1500LBS

BS5163NPT



Tecofi'
VALVE DESIGNER - FRANCE

APPLICATION

General use: Chemical and pharmaceutical industries, petrochemical industries, hydraulic installation, compressed air.

GENERAL CHARACTERISTICS

Full bore
Anti blow-out stem
Packing with elastic rings. Double tightness on stem by PTFE filled with 25% glass fiber packing and FKM O ring. Double tightness between body and ends by FKM O ring and graphite gasket
Antistatic device. Fire safe according to API 607 version 4. Atex
With ISO 5211 mounting pad. Fully encapsulated bolts
1500 lbs



CONSTRUCTION

17	Bolting	ASTMA320 L7
16	Stop Pin	Zinc plated steel 8.8
15	Nut	ASTMA582 303
14	ID plate	Aluminium
13	Handle	Zinc plated steel
12	Elastic ring	Stainless steel 301
11	Gland	Stainless steel 316
10	Packing	Graphite
9	O ring	FKM
8	Thrust washer	PTFE filled with 25% glass
7	Seat	DEVLON®
6	O ring	FKM
5	Body gasket	Graphite
4	Stem	ASTMA479 316
3	Ball	ASTMA479 316
2	Ends	ASTMA350 LF2
1	Body	ASTMA350 LF2
Pos.	Description	Material

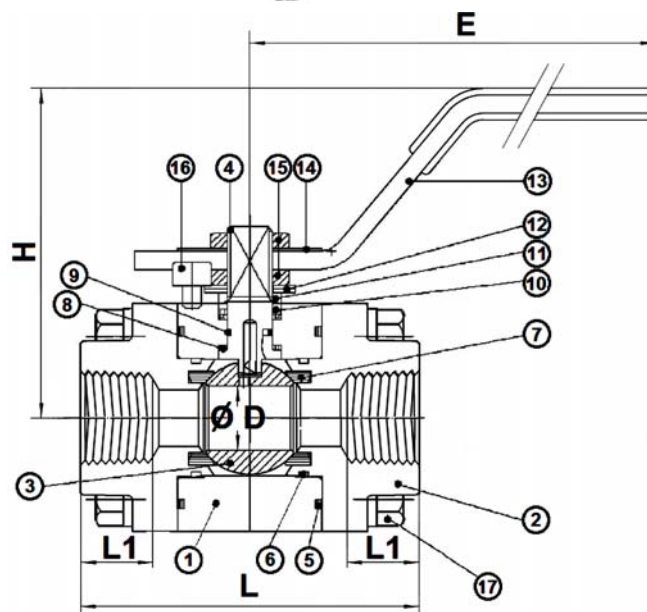

DIMENSIONS

DN		L	H	ØD	E	L1	Stem and ISO plate dimensions						Weight (kg)	
mm	inch						H1	H2	C	ØY	ØK	ISO		Nx ØZ
15	1/2"	87	91	14	170	27.5	12	9.5	7.5	12(M12x1.5)	36	F03	4xM5	2.5
20	3/4"	110	98	19	170	27	18	14	7.5	12(M12x1.5)	36	F03	4xM5	3.2
25	1"	120	119	25	230	27	30	21	8.9	15(M14x1.5)	42	F04	4xM5	4.7
32	1 1/4"	140	124	32.5	230	43	26	15	8.9	15(M14x1.5)	50	F05	4xM5	6.7
40	1 1/2"	160	147	38	310	49	35	24	14	21(M20x1.5)	50	F05	4xM5	10
50	2"	200	168	51	400	62	40	20	18	24(M24x2)	70	F07	4xM5	20

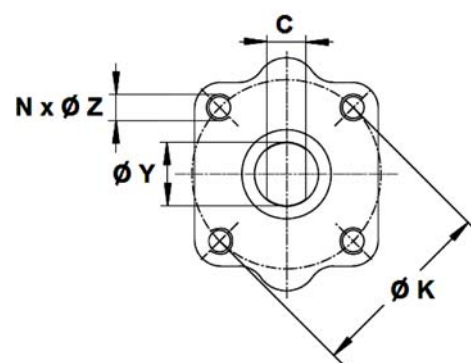
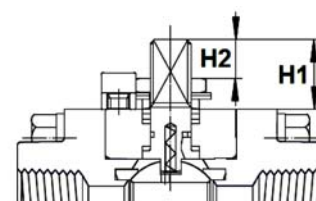

WORKING CONDITIONS

Maximum working pressure : 250 bar
(12 bar maxi for steam).

Working temperature : -46°C/+200°C.

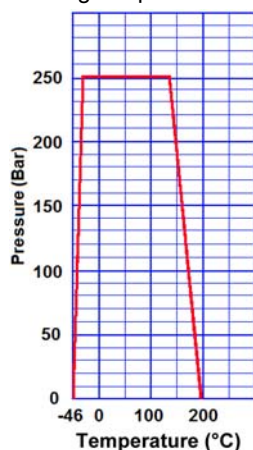

AGREMENT ET NORMES

Fabrication according to ISO 9001 : 2008
DIRECTIVE 97/23/CE. Risk category III module H
Construction according to ISO 17292
Designing according to ASME B16.34. Tests according to API 598
Fire safe according to API 607 version 4
Threaded NPT ends according to ANSI B1.20.1
ISO 5211 mounting pad

TECOFI France - 83, Rue Marcel Mérieux 69960 Corbas - FRANCE
Tél. +33 (0) 4 72 79 05 79 - Fax +33 (0) 4 78 90 19 19 / +33 (0) 4 72 79 05 70
Adresses e-mail : sales@tecofi.fr ; tecofi@tecofi.fr / Site web : www.tecofi.fr