

Ref. : VPN 3449 pas

Rev. : C

Date : 17/09/2015

Page : 1/1

BUTTERFLY VALVE WITH BARE SHAFT

VPN 3449-00



APPLICATION

General use : water, sea water, air, acids etc...
 "Non suitable for steam application"

CARACTERISTIQUES GENERALES

Design according with BS EN 593.
 Type with lugs, tightness in both ways.
 Sleeve in dovetail shape ensures a perfect assembling (for high vacuum we can stick it).
 High and low semi stem giving a high flow coefficient, machined disc on periphery giving a low and regular torque.
 Unejectable stem, dovetail type sleeve, mounting flange according to ISO 5211.

CONSTRUCTION

11	1	Nameplate	Stainless steel 304	
10	2	Circlip	Steel	
9	1	Bottom cover	NBR	
8	2	O ring	EPDM	
7	1	Antidust ring	NBR	
6	1	Anti blowout ring	Stainless steel 420	DIN : 1.4021 ASTM : AISI 420 BS : 420 S 37
5	1	Lower stem	Stainless steel 420	DIN : 1.4021 ASTM : AISI 420 BS : 420 S 37
4	1	Upper stem	Stainless steel 420	DIN : 1.4021 ASTM : AISI 420 BS : 420 S 37
3	1	Sleeve	EPDM CH	In standard
2	1	Disc	GX5CrNiMo19-11-2	DIN: G-X6CrNiMo18 10 ASTM : A 351 Grade CF8M BS: 1504 316 C16
1	1	Body	EN-GJL-250	DIN : GG25 ASTM : A48 class 40B BS : 1452 Grade 250
Pos.	Q-ty	Description	Material	

DIMENSIONS

DN		A	B	C	D	E	F	TYPE	G	H	Weight (kg)
mm	inch										
40**	1 1/2	134	58	34	65	50	8	F05	32	9	1,44
50	2"	139,7	65	41,8	65	50	8	F05	32	9	2,04
65	2 1/2	152,4	73	45,3	65	50	8	F05	32	9	2,44
80	3"	158,8	85	45,3	65	50	8	F05	32	9	3,00
100	4"	178	100	51,5	65	50	8	F05	32	11	3,82
125	5"	190,5	115	54,5	90	70	10	F07	32	11	6,02
150	6"	203	120	54,5	90	70	10	F07	32	14	6,92
200	8"	238	160	59,6	125	102	12	F10	45	17	12,08
250	10"	268,3	195	68	125	102	12	F10	45	22	18,98
300	12"	306,4	230	78	125	102	12	F10	45	22	28,80

** Can be installed between DN32 flanges

WORKING CONDITIONS

Maximum working pressure : 16 bar.

Maximum working temperature : -15°C / +130°C.
 Peak temperature: -30°C / +150°C

Sleeve types in option	Maximum temperature	Peak temperature
EPDM	+4°C / +110°C	-20°C / +130°C
White EPDM	+4°C / +110°C	-20°C / +130°C
CSM (Type Hypalon®)	+4°C / +80°C	-20°C / +110°C
FPM (Type Viton®)	-10°C / +170°C	-20°C / +200°C
Silicone	-20°C / +170°C	-40°C / +200°C
Nitril (NBR)	-10°C / +80°C	-20°C / +90°C

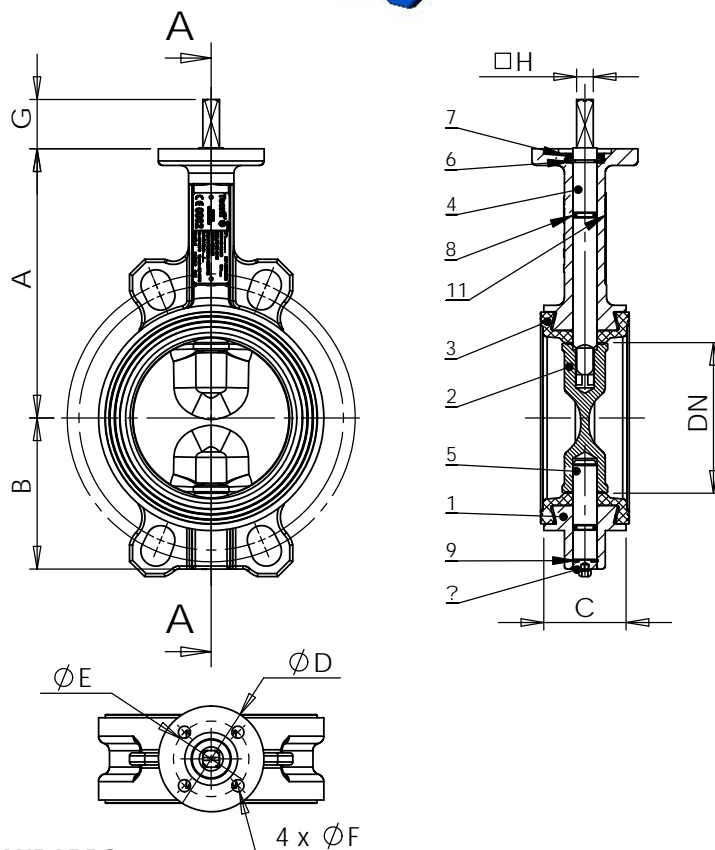

STANDARDS

Manufacture according to the requirements of the European directive 2014/68/UE «Equipment under pressure»: modulate H.
 Face to face according to standards NF EN 558-1 serie 20, ISO 5272 série 20, DIN 3202.
 Mounting between flanges PN 10 / PN 16: according to EN 1092-2, BS 450, ANSI B16.1-5.
 Adjustable between flanges ASME B16.5 Class 150 and JIS 10K.
 Pressure test according to standards EN 12266-1, DIN 3230, BS 6755 and ISO 5208 :
 Corps: 24 bar
 Siège: 17.6 bar

TECOFI France - 83, Rue Marcel Mérioux 69960 Corbas - France
 Tél. +33 (0)4 72 79 05 79 - Fax +33 (0)4 78 90 19 19 / +33 (0)4 72 79 05 79
 Adresses e-mail: sales@tecofi.fr; tecofi@tecofi.fr / site web: www.tecofi.fr