

# KNIFE GATE VALVE STAINLESS STEEL BODY

TECHNICAL PASSPORT

## KNIFE GATE VALVE - RISING STEM WITH ELECTRIC ACTUATOR AUMA STAINLESS STEEL BODY - BETWEEN FLANGES PN10

VG 6400-UX4

### APPLICATION

The knife gate valve is particularly suitable for the most difficult applications.

**Area of use:** water treatment networks, pulp and paper industry, chemical plants, winemaking, cement works, pneumatic transport, storage.



**Fluids:** water, sewage, pulp, pasty products, powdery, granular, fibrous, abrasive and crystallizing.

### GENERAL CHARACTERISTICS

**Range:** DN50 to DN600.

- Knife Gate Valve on/off or regulation with rising stem.
- Molded monobloc body
- Unidirectional water tightness: Flow direction indicated on the body with an arrow.
- Installation between flanges ISO PN10.
- Small retention zone.
- Gate with a beveled cutting edge guided in the body with little backlash.
- Guaranteed closure, without risk of blockage.
- Standard polished gate, soft contact with the gaskets.
- Very resistant stainless steel packing flange avoids risks of breaks.
- Operating force reduced thanks to the elasticity of the gaskets.
- Pre-formed profiled sheet metal support plates from DN50 to DN300 for accessory or kit mounting.
- Full flow when fully opened, ensuring a high flow rate with low head loss.
- Flow regulation possible for pasty or abrasive fluids with installation of a deflector.

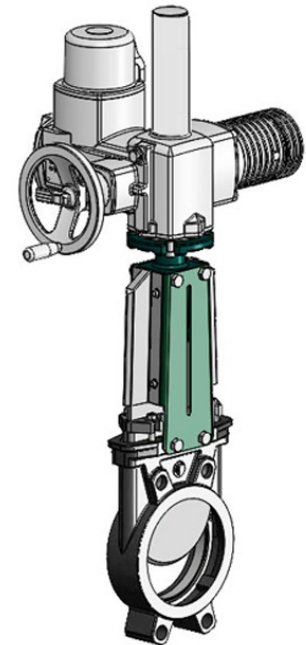

References	Actuator types
VG 6400-U04	AUMA 400V 3PH
VG 6400-B24	AUMA 230V 1PH

### STANDARDS

<b>Design</b>	Manufacture according to the requirements of the European directive n° 2014/68/UE «Equipment under pressure» : modulate H.					
	In option: product conform to European directive ATEX «ATmosphère EXplosive» n° 2014/34/UE.					
<b>Face to face</b>	Face to face dimension according to TECOFI standard					
<b>Connection</b>	Mounting between flanges in accordance with EN1092-2 and ISO 7005-1 : ISO PN10					
<b>Tests</b>	Pressure test according to standards EN12266-1, DIN 3230, BS 5154 and ISO 5208.					
	DN	Body	Seat	DN	Body	Seat
	DN50-250 :	15.4 bar	11 bar	DN300-450:	12.6 bar	7.7 bar
	DN500-600:	7.2 bar	4.4 bar			

### PRODUCT APPROVALS



### Tecofi France

83 rue Marcel Mérieux - 69960 Corbas  
Tél. +33 (0)4 72 79 05 79 - Fax. +33 (0)4 78 90 19 19  
E-mail : sales@tecofi.fr - [www.tecofi.fr](http://www.tecofi.fr)



## KNIFE GATE VALVE STAINLESS STEEL BODY

TECHNICAL PASSPORT

VG 6400-UX4

### CONSTRUCTION

Coatings applied on the valve :

Component	Coating
Support plate (8)	Liquid epoxy RAL 6005 70 microns
ISO plate (23)	

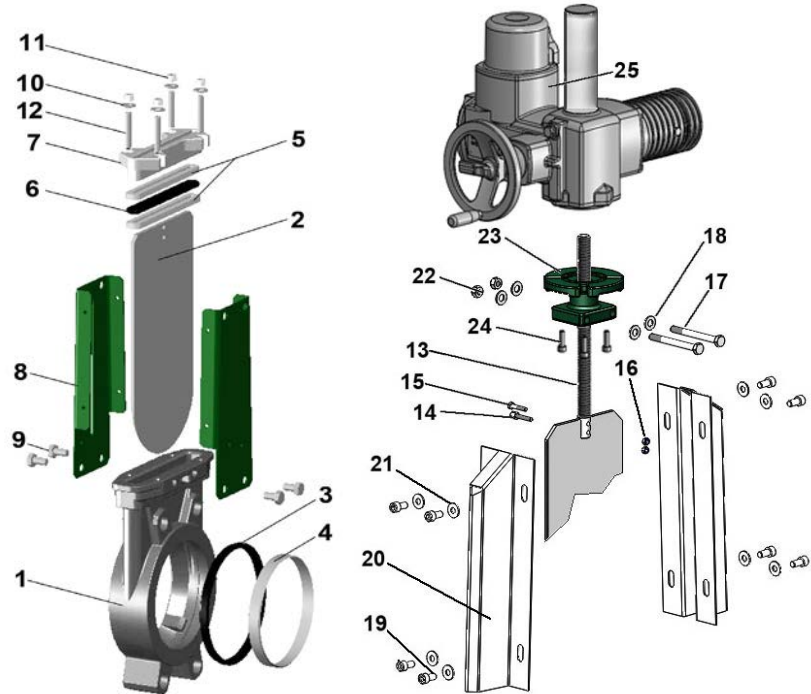

Pos.	Q-ty	Description	Material	Equivalence		
				DIN	ASTM	BS
1	1	Body	Stainless steel GX5CrNiMo 19-11-2	G-X6CrNiMo18 10	A 351 grade CF8M	316 C16
2	1	Gate	Stainless steel X2CrNi 17-12-2	X2CrNiMo17-13-2	A 182 AISI 316L	1449-2 316 S11
3	1	Seat gasket (1)	NBR			
4	1	Support ring (1)	Stainless steel X5CrNi 18 10	X5CrNiMo18 10	A 182 AISI 316	1449-2 316 S16
5	2	Packing	PTFE			
6	1	O-Ring	NBR			
7	1	Packing gland	Stainless steel GX5CrNiMo 19-11-2	G-X6CrNiMo18 10	A 351 grade CF8M	316 C16
8	2	Support plate	Steel			
9	4**	Screw	Stainless steel A2-70			
10	4*	Washer	Stainless steel A2-70			
11	4*	Nut	Stainless steel A2-70			
12	4*	Tie rod	Stainless steel A2-70			
13	1	Stem	Stainless steel 13% Cr	X12CR13	AISI 410	
14	1	Detection screw	Stainless steel X5CrNi 18 10	X5CrNi 18 10	A 182 AISI 304	1449-2 304 S15
15	1	Screw	Stainless steel A2-70			
16	2	Nut	Stainless steel X5CrNi 18 10	X5CrNi 18 10	A 182 AISI 304	1449-2 304 S15
17	2	Screw	Stainless steel A2-70			
18	4	Washer	Stainless steel A2-70			
19	8	Screw	Stainless steel A2-70			
20	2	Protection cap	Stainless steel X5CrNi 18 10	X5CrNi 18 10	A 182 AISI 304	1449-2 304 S15
21	8	Washer	Stainless steel A2-70			
22	2	Nut	Stainless steel A2-70			
23	1	ISO 5210 plate	Steel A45			
24	4	Screw	Stainless steel A2-70			
25	1	Electric actuator	AUMA model			

\* - 8 for DN350-400; \*\* - 12 for DN450-600 (1) - Parts missing on valves with metal/metal sealing

**Tecofi France**

83 rue Marcel Mérieux - 69960 Corbas  
Tél. +33 (0)4 72 79 05 79 - Fax. +33 (0)4 78 90 19 19  
E-mail : sales@tecofi.fr - [www.tecofi.fr](http://www.tecofi.fr)



## KNIFE GATE VALVE STAINLESS STEEL BODY

TECHNICAL PASSPORT

VG 6400-UX4

### DIMENSIONS

DN		Type moteur	A	B	C	D	M	M1	N	ØV	H	Weight (kg)
mm	inch											
50	2"	SA07.2	40	383	124	83	249	265	237	160	578	27
65	2 1/2"	SA07.2	40	408	139	83	249	265	237	160	603	29
80	3"	SA07.2	50	433	154	83	249	265	237	160	628	30
100	4"	SA07.2	50	478	174	83	249	265	237	160	673	31
125	5"	SA07.6	50	516	189	93	249	265	237	160	711	38
150	6"	SA07.6	60	567	220	93	249	265	237	160	762	42
200	8"	SA07.6	60	686	275	108	249	265	237	160	881	57
250	10"	SA10.2	70	778	326	108	254	283	237	160	973	75
300	12"	SA7.6	70	887	380	108	249	265	247	200	1082	87
350	14"	SA10.2	96	990	438	290	254	283	247	200	1185	137
400	16"	SA10.2	100	1100	494	290	254	283	247	200	1295	167
450	18"	SA14.2	106	1225	547	290	336	389	285	315	1430	231
500	20"	SA14.2	110	1335	613	290	336	389	285	315	1540	266
600	24"	SA14.2	110	1539	716	290	336	389	285	315	1744	310

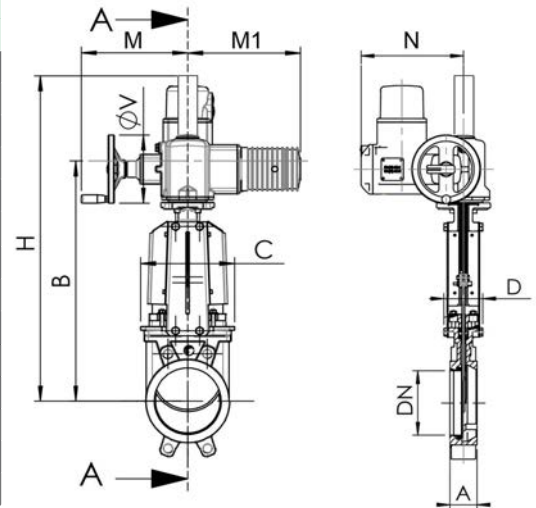

Dimension A - face to face according to TECOFI standard

### MOUNTING

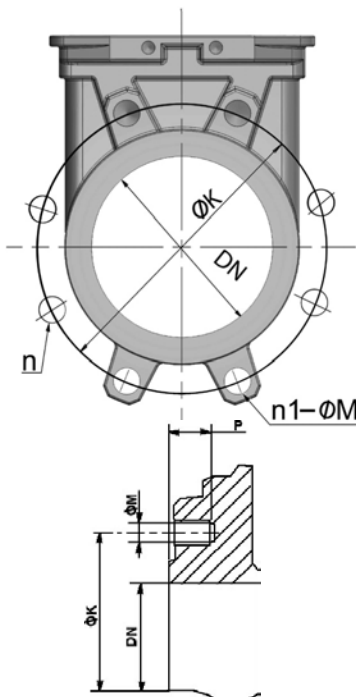

Body details

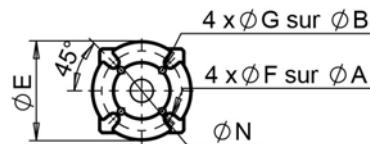

ISO plate

DN		Maximum pressure (bar)	n	n1-ØM	P	ØK	ISO plate	ØA	ØB	ØE	ØF	ØG	ØN
mm	inch												
50	2"	10	4	4xM16	8	125	F07/F10	70	102	125	9	11	70
65	2 1/2"	10	4	4xM16	8	145	F07/F10	70	102	125	9	11	70
80	3"	10	8	4xM16	9	160	F07/F10	70	102	125	9	11	70
100	4"	10	8	4xM16	9	180	F07/F10	70	102	125	9	11	70
125	5"	10	8	4xM16	9	210	F07/F10	70	102	125	9	11	70
150	6"	10	8	4XM20	10	240	F07/F10	70	102	125	9	11	70
200	8"	10	8	4XM20	12	295	F10	102	-	125	12	-	70
250	10"	10	12	8XM20	12	350	F10	102	-	125	12	-	70
300	12"	7	12	8XM20	19	400	F10	102	-	125	12	-	70
350	14"	7	16	10XM20	20	460	F10/F14	102	140	175	11	17	100
400	16"	7	16	10XM24	24	515	F10/F14	102	140	175	11	17	100
450	18"	7	20	14XM24	24	565	F10/F14	102	140	175	11	17	100
500	20"	4	20	14XM24	24	620	F10/F14	102	140	175	11	17	100
600	24"	4	20	14XM27	24	725	F10/F14	102	140	175	11	17	100

n- Total number of holes

n1- number of threaded holes

**Tecofi France**

83 rue Marcel Mérieux - 69960 Corbas

Tél. +33 (0)4 72 79 05 79 - Fax. +33 (0)4 78 90 19 19

E-mail : sales@tecofi.fr - [www.tecofi.fr](http://www.tecofi.fr)



# KNIFE GATE VALVE STAINLESS STEEL BODY

## TECHNICAL PASSPORT

**VG 6400-UX4**

### WORKING CONDITIONS

Maximum working pressure : DN50-250 : 10 bar  
DN300-450 : 7 bar  
DN500-600 : 4 bar

Maximum working temperature : -10°C / +130°C (EPDM joint in standard)

**▲** The above mentioned pressures are only valid if the direction of assembly indicated by the arrow on the valves is observed.

#### Upstream/downstream tightness

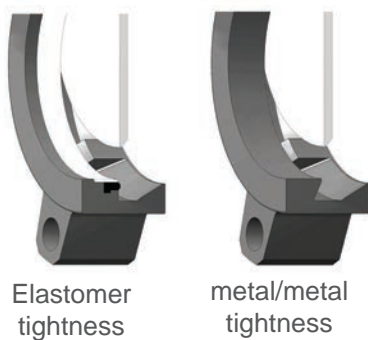

#### Packing tightness

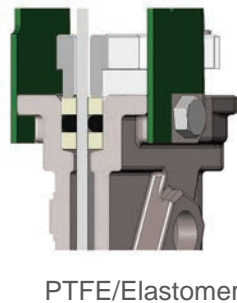

#### Tightness in option

Tightness	Maximum temperature
Metal/metal	Tmax : -10°C / +80°C
NBR	Tmax : -10°C / +80°C
White EPDM	Tmax : -10°C / +130°C
Silicone	Tmax : -10°C / +170°C
FPM (Type Viton®)	Tmax : -10°C / +170°C
PTFE	Tmax : +4°C / +170°C
CSM (Type Hypalon ®)	Tmax : +4°C / +80°C

**▲** To ensure a satisfactory tightness, when using the PTFE gasket, the operating pressure must be at least 1 bar.

### FLOWS

#### Kv of valves (m<sup>3</sup>/h)

DN		Operating stroke, %									
mm	inch	10%	20%	30%	40%	50%	60%	70%	80%	90%	100%
50	2"	1,41	7,57	18,4	33,27	52,61	74,78	98,45	120,81	149,53	161,66
65	2"1/2	2,41	8,58	25,4	49,32	85,77	121,51	167,85	219,67	287,45	317,77
80	3"	3	13,1	46,66	79,57	122,11	199,58	276,85	359,84	432,49	461,98
100	4"	3,86	33,06	75,62	125,01	206,17	311,72	474,43	681,36	865,17	993,21
125	5"	19,64	47,05	107,47	177,8	295,95	444,71	675,13	973,05	1231,14	1385,15
150	6"	28,88	104,25	181,37	281,61	418,76	614,83	884,79	1177,11	1482,44	1613,77
200	8"	24,04	141,73	251,71	418,72	514,76	785,11	1227,16	1982,56	2491,22	2783,27
250	10"	115,44	367,52	693,84	1141,65	1634,09	2342,79	3243,71	3960,67	5336,19	5951,8
300	12"	103,12	535,87	1023,55	1619,5	2441,26	3508,29	4553,83	6339,29	7862,36	8373,88
350	14"	218,4	725,8	1323	2173,2	3294,8	4914,3	7120,9	11415,3	19105,4	24890,7
400	16"	389,1	1150,1	2024,4	3130,9	4669,6	7009,1	10355,2	16014,2	22600,5	26497,7
450	18"	402,7	1287,3	2402,9	3803,4	5686,8	8247,3	12248,7	17298,5	26403,9	29485
500	20"	617	1611,1	2935,9	4625,8	7054,7	10438,9	15446	23582,8	35107,4	42784

**Tecofi France**

83 rue Marcel Mérieux - 69960 Corbas  
Tél. +33 (0)4 72 79 05 79 - Fax. +33 (0)4 78 90 19 19  
E-mail : sales@tecofi.fr - [www.tecofi.fr](http://www.tecofi.fr)

